

Office of Engineer, Surveys & Construction
Detroit, Michigan

Date: October 17, 1989

File:

Application for Wire Crossing No: 2777

Name of Applicant: Detroit Edison Co.

Letter Dated: 9/21/89 Applicant's Plan No. 3187-WX-1 Date: 9/13/89
RX 4529

Location: Pontiac, Michigan

Mile Post: 2.27 Subdivision: Cass City

Brief description of proposed crossing or encroachment:

- Three - 795 MCM 26/7, ACSR, 12 KV Wires
- Three - 795 MCM 26/7, ACSR, 4.16 KV Wires
- One - 3/8" Steel Ground Wire

On or over Railroad property, in Street or Private Property:

On GMC Property

Remarks and Recommendations:

No objection to proposed reconstruction. A license is not required.

W. LaMasters

W. LaMasters
Engineer, Surveys & Construction

Approval:

[Signature]

Engineer, Communications

J. P. Anders

Chief Engineer File: D 26-16-6

A. H. Callwood

* Director, Industrial and Resource
Development

* Please return Approved Copy to
Office of Engineer

RECORDED RIGHT OF WAY NO. 9064 P533

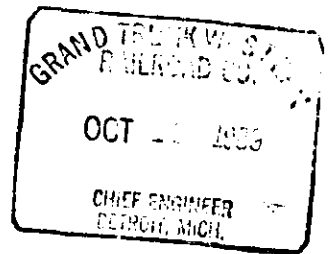

Office of Engineer, Surveys & Construction
Detroit, Michigan

Date: October 17, 1989

File:

Application for Wire Crossing No: 2778

Name of Applicant: Detroit Edison Co.

Letter Dated: 9/21/89 Applicant's Plan No. 3063-WX-6 Date: 9/13/89
RX 4529

Location: Pontiac, Michigan

Mile Post: 2.39 Subdivision: Cass City

Brief description of proposed crossing or encroachment:

- Three - 795 MCM 26/7, ACSR, 12 KV Wires
- Three - 795 MCM 26/7, ACSR, 4.16 KV Wires
- One - 3/8" Steel Ground Wire

On or over Railroad property, in Street or Private Property:

On GMC Property

Remarks and Recommendations:

No objection to proposed reconstruction. A license is not required.

W. LaMasters
W. LaMasters
Engineer, Surveys & Construction

Approval:

L. B. Brown

Engineer, Communications

J. Q. Anderson

Chief Engineer File: D 26-16-6

A. H. Callaway

* Director, Industrial and Resource
Development

* Please return Approved Copy to
Office of Engineer

RECORDED RIGHT OF WAY NO. 9064 P533

**Detroit
Edison**

1000 Second Avenue
Detroit, Michigan 48226
(313) 237-8000

September 21, 1989

W. La Masters
Engineer of Surveys and Construction
Grand Trunk Western Railroad Company
1333 Brewery Park Boulevard
Detroit, MI 48207-2699

Re: Wire Crossing Notification

Dear Mr. LaMasters:

This letter is your notice of the planned reconstruction of an overhead wire crossing over your railroad tracks within the property of the General Motors Corporation, by The Detroit Edison Company, in the Northwest 1/4 of Section 17, City of Pontiac, Oakland County, Michigan.

1. Location: Crossing No. 1 - 972' north of Columbia Street and 650' east of Price Street
Crossing No. 2 - 330' north of Columbia Street and 620' east of Price Street
2. Edison Project & Crossing Nos.: BO 0599 and RX 4529
3. This is a reconstruction of existing crossings. Previous agreement dates: Consumers No. 3063-WX-3 of January 10, 1966 and Consumers No. 3187-WX-1 of October 4, 1967
4. Please indicate your:
R.R. Valuation Station No. _____
R.R. Mile Post No. _____
Requirements for Flagman or Inspection _____

All construction will be done in accordance with specifications of the Michigan Public Service Commission and all applicable codes and laws.

In the event you do not acknowledge receipt of this letter within 45 days of the above date, our crews will be instructed to begin work.

RECORDED RIGHT OF WAY NO.

9064 P533

September 19, 1989

Page Two

Please contact Brenda L. Golson our Real Estate Coordination Specialist, Railroads on (313) 237-8316 if you have any questions.

Sincerely,

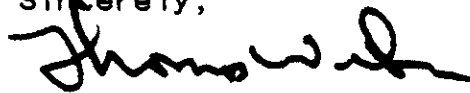

Thomas Wilson
Real Estate Associate

TW/blg

attachments

cc: C. F. VanParis

RECORDED RIGHT OF WAY NO.

9064 1593

DATA SHEET TO ACCOMPANY DRAWING RX-4529

Revision of Crossing No.1 Consumers Power

File No. 3063-WX-3 Covered under M.P.S.C. No. EC3-8-11236, Dated 1-10-66.

Revision of Crossing No. 2 Consumers Power

File No. 3187-WX-1 Covered under M.P.S.C. No. EC3-8-11741 Dated 10-4-67.

Name of Company

The Detroit Edison Company

Name and Location of Crossing

Crossing of the Bloomfield-Tempest 120-kv transmission circuit and Tie 2640, 41.6-kV subtransmission circuit over the Grand Trunk Western Railroad.

Crossing No. 1. 972 feet north of Columbia Street and 650 feet east of Price Street.

Crossing No. 2. 330 feet north of Columbia Street and 620 feet east of Price Street.

Crossing 1 and 2 are located in the northwest 1/4 of Section 17, City of Pontiac, Pontiac Township, Oakland County, Michigan.

Circuits

One 120,000 volt and one 41,600 volt, 60 cycle, 3 phase-3 wire circuits with one ground wire.

Towers and Crossarms

See attached drawing ED1-9856.

Conductors

Six 795 MCM 26/7 ACSR with one 3/8" steel ground wires.

Insulators

Deadend: Nine 5-3/4" x 10" insulators
Suspension: Eight 5-3/4" x 9 1/2" insulators

Transmission and Civil Engineering
CVP/fmm 09/13/89

RECORDED RIGHT OF WAY NO. 9064 1533

Guy and Guy Attachments

None.

Suspension and Deadend Details

See attached drawing ED1-7572.

fmm
RX-4529

RECORDED RIGHT OF WAY NO.

9064 P533

Transmission and Civil Engineering
CVP/fmm 09/13/89

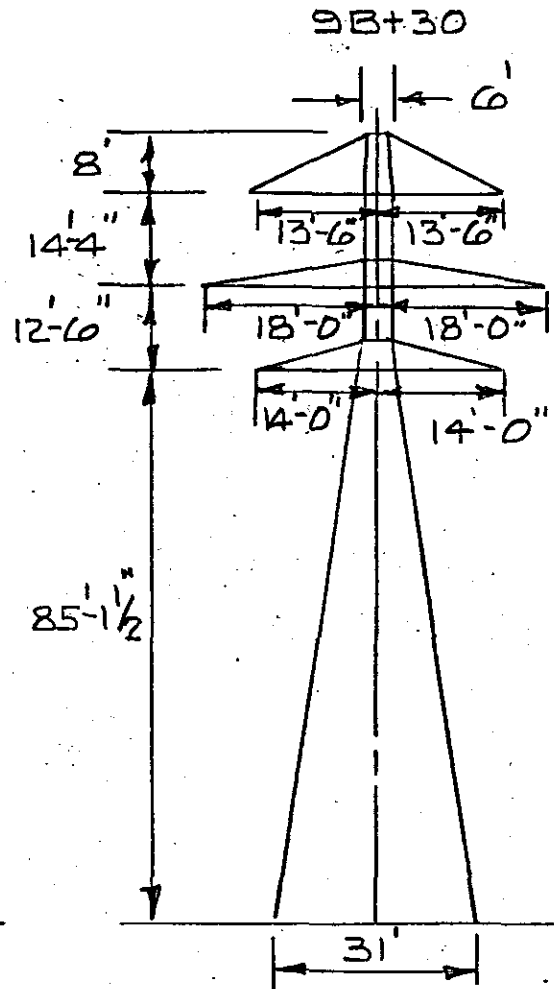
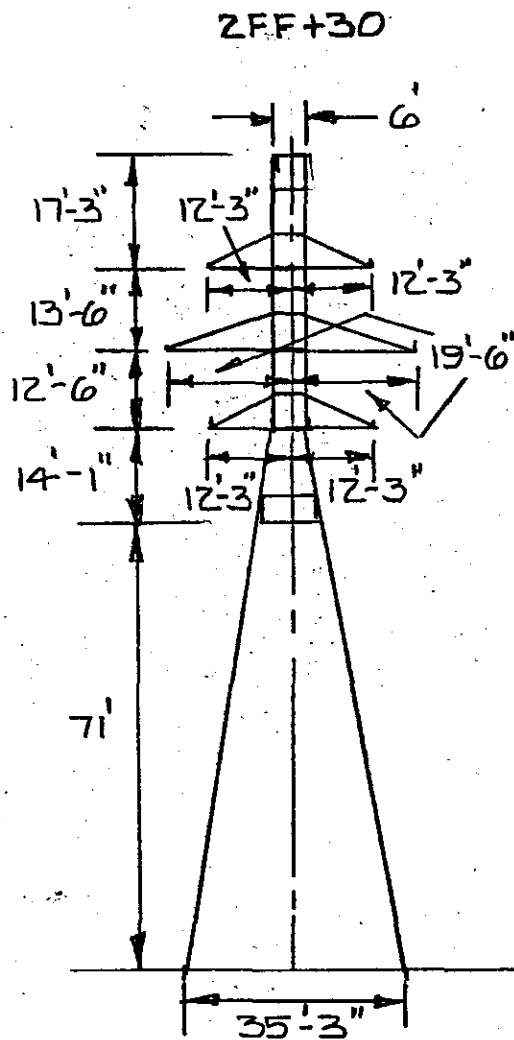
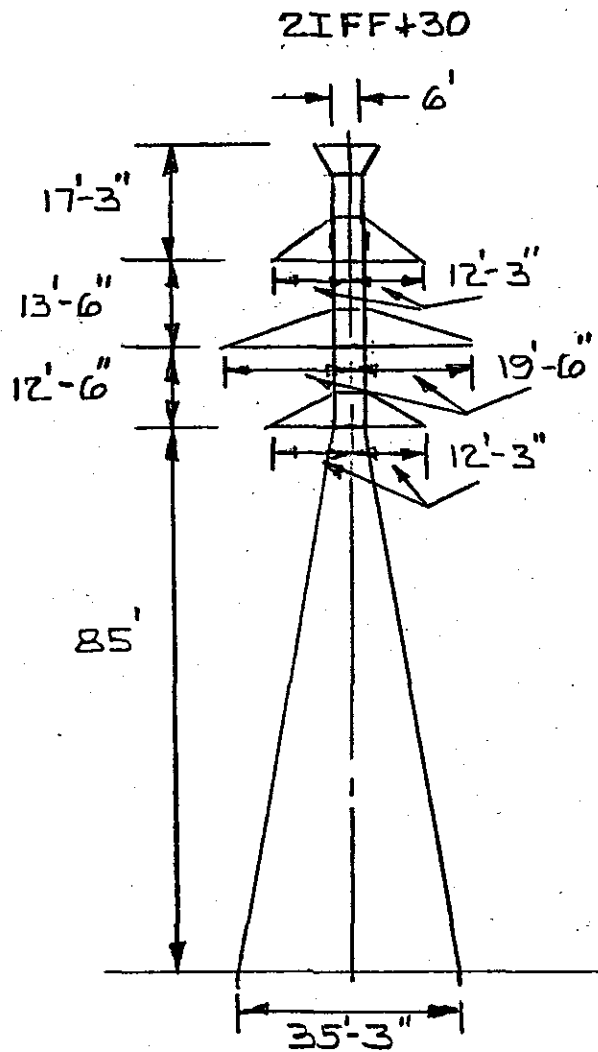

9064/1338 RECORDED RIGHT OF WAY NO.

DESIGN DIMENSIONS OF
2IFF+30, 2FF+30, 9B+30

APPROVED

M. J. P.

THE DETROIT EDISON COMPANY
TRANSMISSION PROJECTS

LAYOUT BY C. VAN

DRAWN BY PARIS

DATE 9-2-89

DRAWING NUMBER

SCALE 1"=30'

EDI-9856

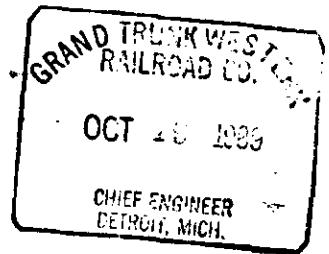

Office of Engineer, Surveys & Construction
Detroit, Michigan

Date: October 17, 1989

File:

Application for Wire Crossing No: 2778

Name of Applicant: Detroit Edison Co.

Letter Dated: 9/21/89 Applicant's Plan No. 3063-WX-6 Date: 9/13/89
RX 4529

Location: Pontiac, Michigan

Mile Post: 2.39 Subdivision: Cass City

Brief description of proposed crossing or encroachment:

- Three - 795 MCM 26/7, ACSR, 12 KV Wires
- Three - 795 MCM 26/7, ACSR, 4.16 KV Wires
- One - 3/8" Steel Ground Wire

On or over Railroad property, in Street or Private Property:

On GMC Property

Remarks and Recommendations:

No objection to proposed reconstruction. A license is not required.

W. LaMasters
W. LaMasters
Engineer, Surveys & Construction

Approval:

L. Brown

Engineer, Communications

J. O. Anders

Chief Engineer File: D 26-16-6

A. H. Callaway

* Director, Industrial and Resource
Development

* Please return Approved Copy to
Office of Engineer

RECORDED RIGHT OF WAY NO. 9064 P533

Office of Engineer, Surveys & Construction
Detroit, Michigan

Date: October 17, 1989

File:

Application for Wire Crossing No: 2777

Name of Applicant: Detroit Edison Co.

Letter Dated: 9/21/89 Applicant's Plan No. 3187-WX-1 Date: 9/13/89
RX 4529

Location: Pontiac, Michigan

Mile Post: 2.27 Subdivision: Cass City

Brief description of proposed crossing or encroachment:

Three - 795 MCM 26/7, ACSR, 12 KV Wires
Three - 795 MCM 26/7, ACSR, 4.16 KV Wires
One - 3/8" Steel Ground Wire

On or over Railroad property, in Street or Private Property:

On GMC Property

Remarks and Recommendations:

No objection to proposed reconstruction. A license is not required.

W. LaMasters

W. LaMasters
Engineer, Surveys & Construction

Approval:

John Brown
Engineer, Communications

J. P. Anders
Chief Engineer File: D 26-16-6

A. H. Callwood
* Director, Industrial and Resource
Development

* Please return Approved Copy to
Office of Engineer

RECORDED RIGHT OF WAY NO. 9064 P533