



A CMS Energy Company

1945 West Parnall Road
Jackson, MI 49201-8643

May 5, 2006

EXPRESS MAIL

Phil Mann
Michigan Electric Transmission Company, LLC
c/o NSI Consulting and Development, Inc.
26657 Woodward Ave, Suite 100
Huntington Woods, MI 48070

SUBJECT: Proposed Use of Alma-Summerton Future Double Circuit Structures
Reference No: Chippewa Township/Isabella County/Lott

REFERENCE: Amended and Restated Easement Agreement (the "Agreement") dated April 29, 2002, between Consumers Energy Company ("Consumers") and Michigan Electric Transmission Company, now Michigan Electric Transmission Company, LLC ("METC")

Pursuant to Section 7.1 of the Agreement, Consumers hereby notifies METC that Consumers intends to add a new 46 kV circuit to existing future double circuit structures #191 through #218 of the Summerton-Alma line. This portion of the Summerton-Alma line begins at structure #191 in Section 36, T14N-R04W, Union Township, Isabella County, passes through Section 31, T14N-R03W, Chippewa Township, Isabella County, and runs north to structure #218 in Section 30, T14N-R03W, Chippewa Township, Isabella County.

METC Planning has reviewed this proposed use and responded that it is acceptable.

The location of the lands on which the subject future double circuit structures are located, and a further description of the intended use, are set forth on "Annex A", attached to this letter. Also included with this notification are additional documents showing the proposed pole top designs to be used, the record wire arrangement drawings, a construction list sheet for each structure Consumers proposes to use, and a Form 391 summarizing the proposed use.

Under said Section 7.1 of the Agreement, METC must within 30 days of this notice notify Consumers, as "Initiating User," of whether or not METC approves the proposed use as a Compatible Use. If you do not notify us either way within 30 days of this notice, then, as provided in said Section 7.1, METC will be deemed to have approved the proposed use as being a Compatible Use. We would appreciate, however, receiving METC's express approval of the proposed use as being a Compatible Use as soon as possible so that we can start work without delay.

This letter is being sent to you in duplicate. If METC agrees that the proposed use is a Compatible Use, please indicate that by signing and returning a copy of this letter to us as soon as possible, so that we can immediately proceed with construction. The other copy is for your records.

May 5, 2006

Page Two

Reference No: Chippewa Township/Isabella County/Lott

If METC believes the proposed use is not a Compatible Use, please provide an explanation with your response to help aid in the resolution that would follow.

Sincerely,



K.C. Lott
System Planning & Protection
Consumers Energy
1945 West Parnall Road
Jackson, MI 49201-8643

Cc: *GABultsma, Grand Rapids 203 *BDBugbee, P12-1017A
 *BGott, PE-A402 *TJSparks, P24-332B
 *RACollins, Grand Rapids 201-C *JRanderson, P11-510A
 *KARudolph, P24-414B *MAMarr, EP7-428

* Letter only (no attachments)

APPROVED:

MICHIGAN ELECTRIC TRANSMISSION
COMPANY, LLC

By:  _____

Date: 6/6/06

ANNEX A

May 5, 2006

Reference No: Chippewa Township/Isabella County/Lott

LAND TO BE IMPACTED:

That certain strip of land in Chippewa Township, County of Isabella, State of Michigan, described as follows:

See attached highlighted patrol map: Future double circuit structures located in Section 36, T14N-R04W, in Union Township, Isabella County; and Section 31, T14N-R03W and Section 30, T14N-R03W, in Chippewa Township, Isabella County.

PROPOSED USE:

Pursuant to Section 7.1 of the Agreement, Consumers hereby notifies METC that Consumers intends to add a new 46 kV circuit to the existing future double circuit structures #191 through #218 of the Summerton-Alma line. This portion of the Summerton-Alma line begins at structure #191 in Section 36, T14N-R04W, Union Township, Isabella County, passes through Section 31, T14N-R03W, Chippewa Township, Isabella County, and runs north to structure #218 in Section 30, T14N-R03W, Chippewa Township, Isabella County.

CONSUMERS ENERGY
NOTIFICATION OF PROPOSED LINE CONSTRUCTION
REQUIRING COORDINATION WITH TRANSMISSION LINES

Send two (2) copies to:

Transmission Lines Design and Standards

Att: _____

Jackson, Michigan

TO BE FILLED IN BY SYSTEM OWNER / ENGINEER / CES

Headquarters _____

Work Order No. _____

Date _____

PROPOSED DISTRIBUTION CONSTRUCTION

Sketch Attached Yes No

Primary:

Voltage 46kV Phase 3

No. of Wires 3 Crossarms Per Pole 3-HP

Wire Size 336.4 ACSR Length of Crossarms _____

Distance Below Transmission Attaching 2nd Circuit

Skip-Span Yes No

Secondary:

No. of Wires _____ Wire Size _____

Other Details: Attach 2nd circuit to existing FDC line. Pole top drawings included, detailing 2nd circuit attachment.

TO BE FILLED IN BY TRANSMISSION LINES DESIGN
AND STANDARDS OR METC

Engineering Required Yes No

Checked By _____ Date _____

GWO No. _____

EXISTING DISTRIBUTION FACILITIES

Description:

LOCATION

Township Chippawa & Union County Isabella

Section 30, 31, & 36 Range R03 & R04

Transmission Line Involved 6AF Alma-Summerton

Transmission Pole No. 191 thru 218

METC Line

REMARKS:

Prepared By Michael J. Newsome (517) 788-8906
System Planning and Performance / Electric Service

Date May 4, 2006

Approved By _____
Transmission Lines Design and Standards

Date _____

Approved By _____
METC

Date _____

METC lines are subject to the easement rights of METC. Your request has been forwarded to Real Estate for processing and will require a 30-day period prior to approval. Initiation of any construction activities without appropriate METC approval may require relocation or removal of the lines at your expense.

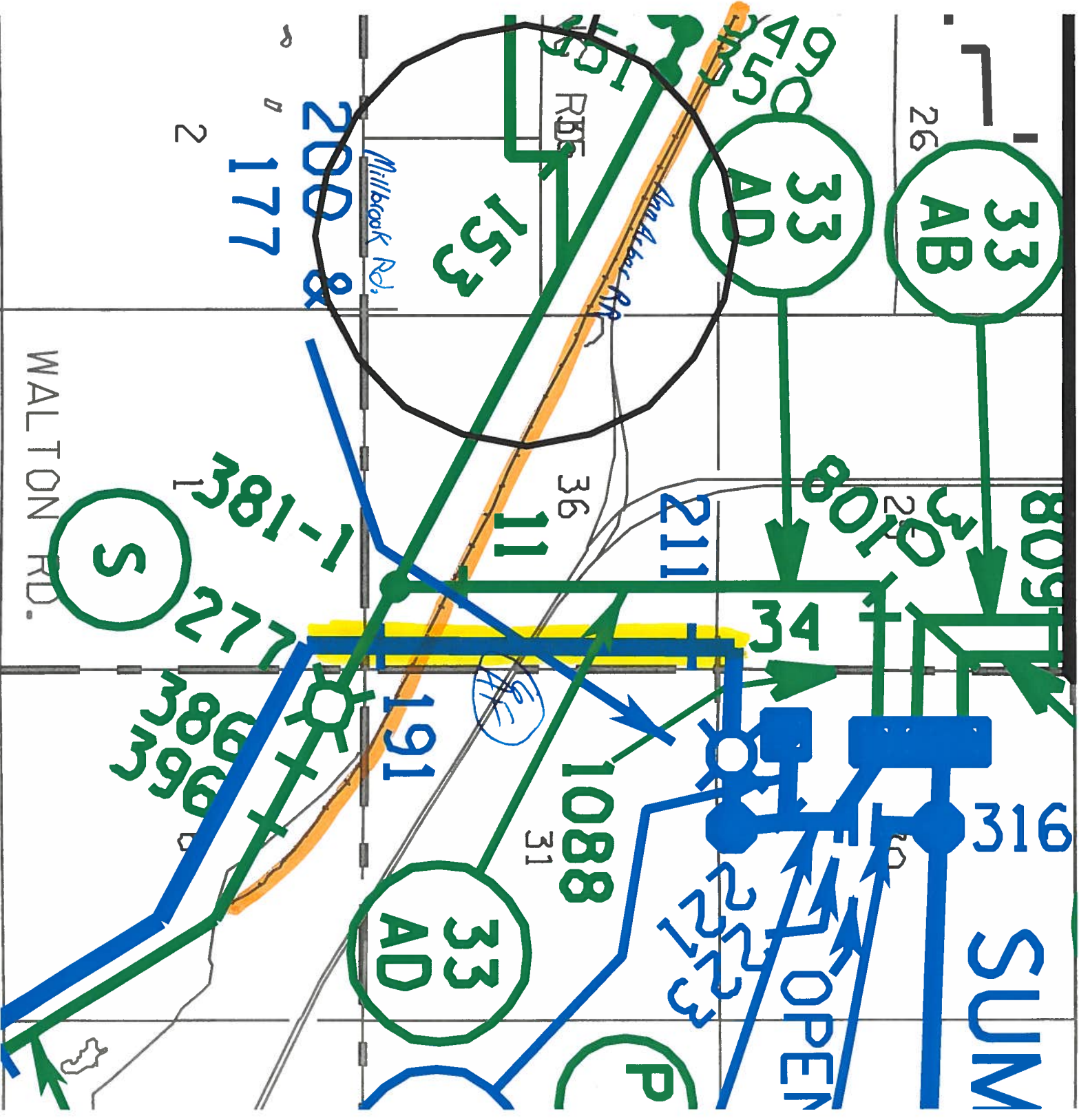

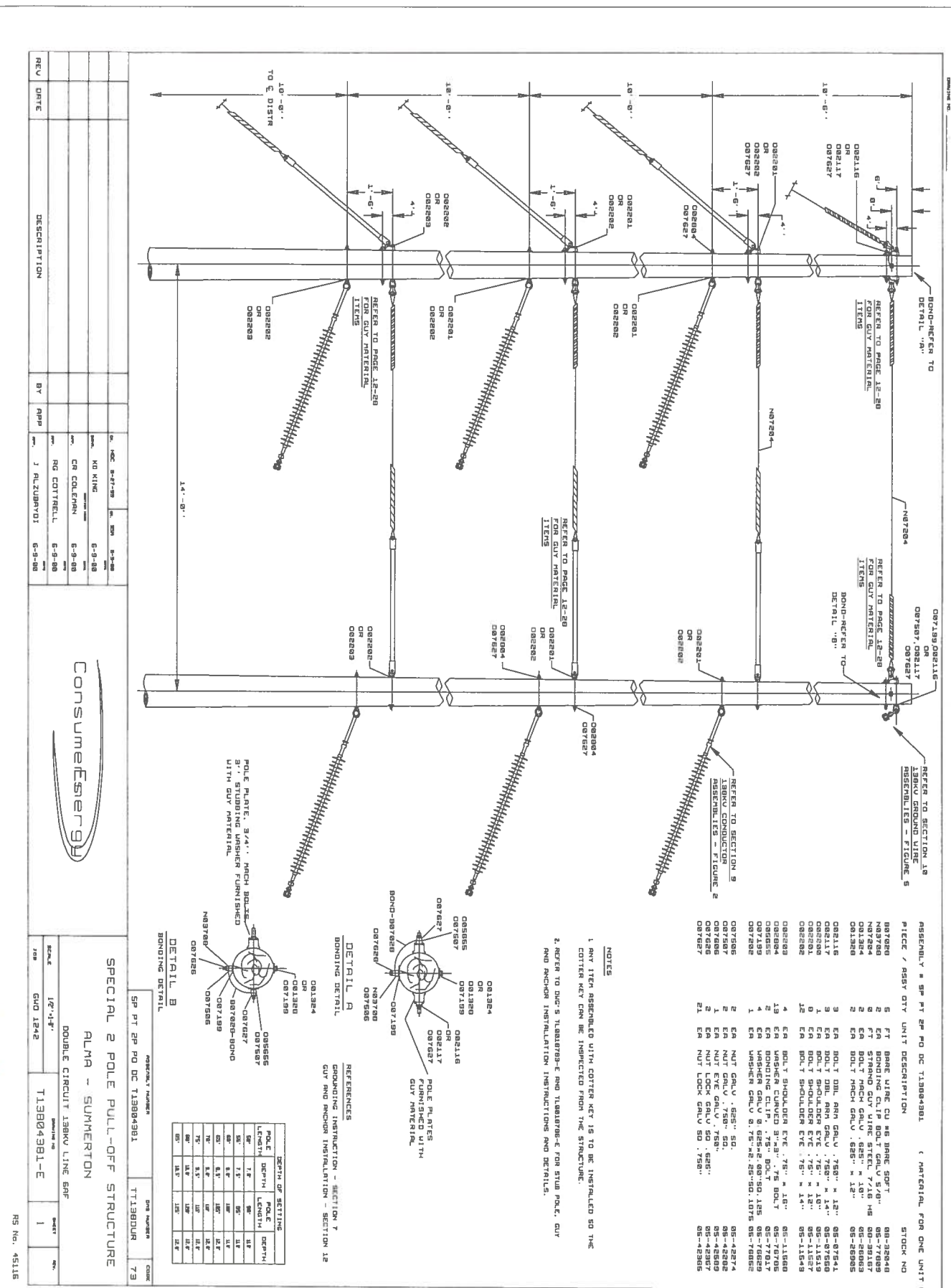

FORM SCALE = 24

PLOTTING SCALE = 2

DRAWING SCALE : 1/2" = 1'-0"

Rev# 1/1, 2002, \$ 203

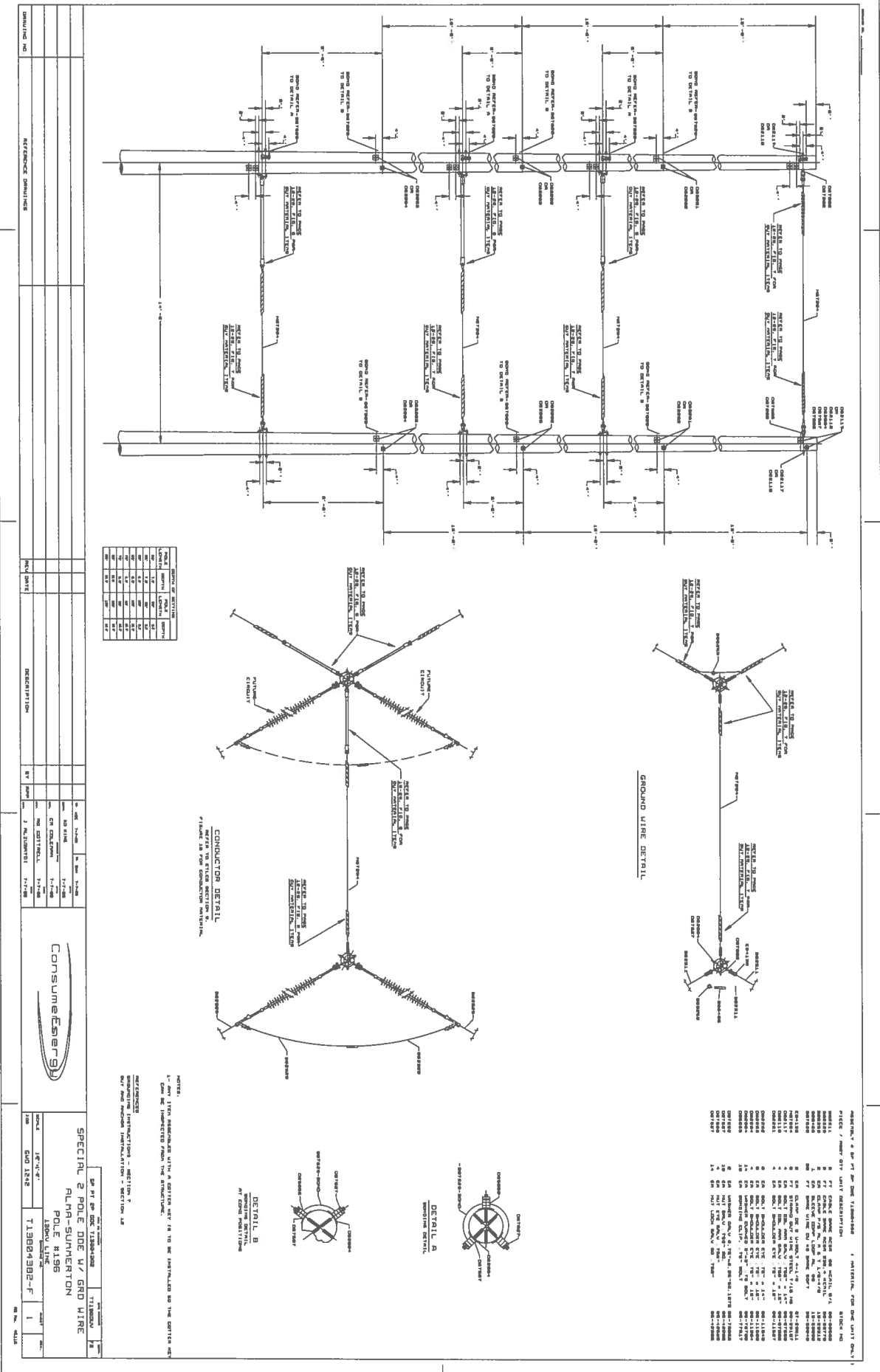

FORM SCALE = 24
 PLOTTING SCALE = 2
 DRAWING SCALE : 1/2" = 1'-0"
Pole # 196



SPECIAL 2 POLE ONE W/ GRD WIRE
 Poles-Summerston
 Pole #196
 13804-982-F
 1

REV	DATE	DESCRIPTION	BY	APP'D	DATE

NO KING	6-14-03
CR COLEMAN	6-14-03
RG CONTRELL	6-14-03
J. ALZUBAYDI	6-14-03

ConsumersEnergy

SP PT	HP	LA	GP	T13904380
HORIZONTAL POST LIGHT ANGLE STRUCTURE				
ALMA-SUMMERTON				
18KV LINE				
REV	DATE	DESCRIPTION	BY	APP'D

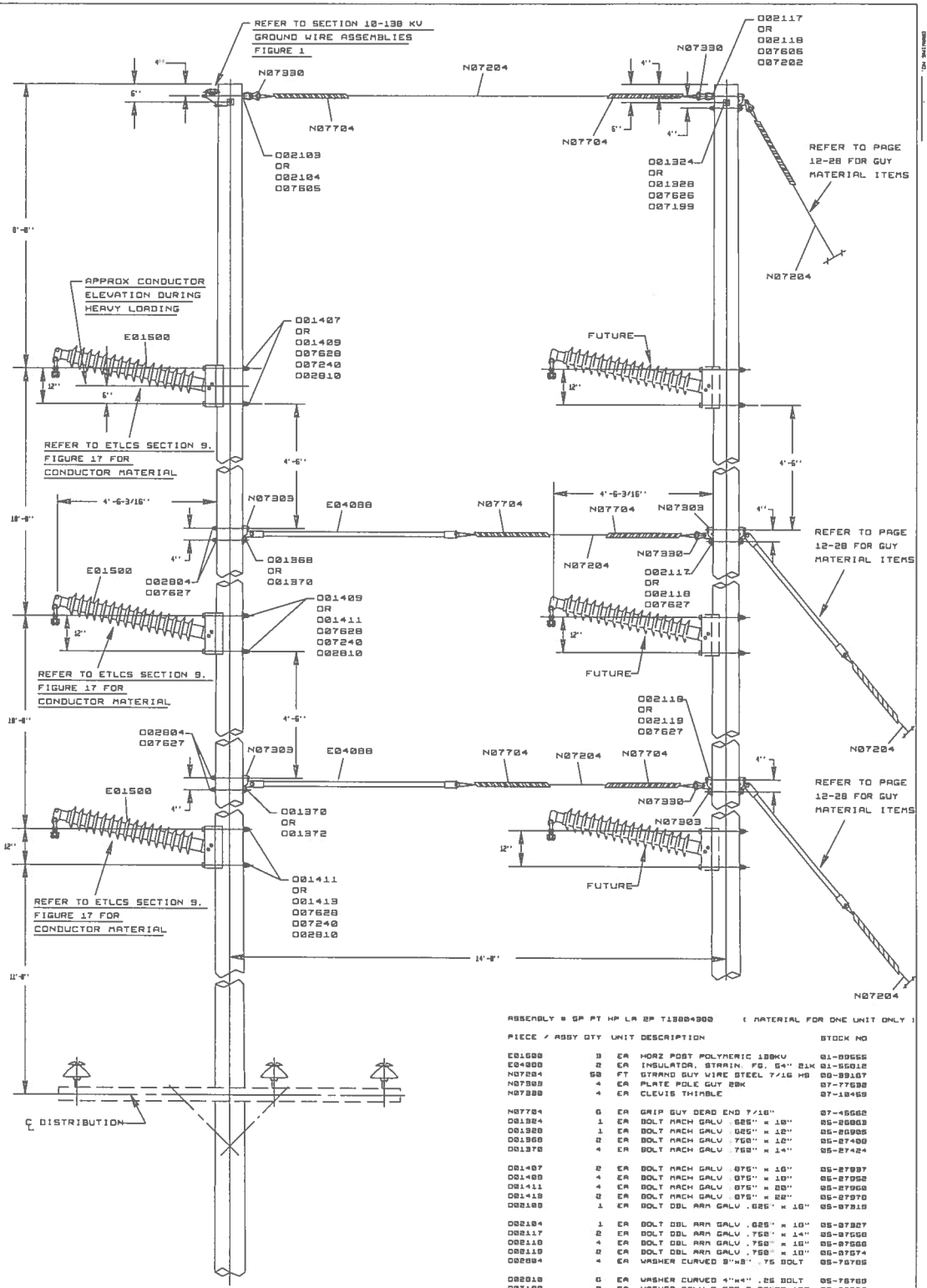

DEPTH OF SETTING			
POLE LENGTH	DEPTH	POLE LENGTH	DEPTH
55'	7.0'	80'	14.0'
60'	8.0'	85'	15.0'
65'	9.0'	90'	16.0'
70'	10.0'	95'	17.0'
75'	11.0'	100'	18.0'
80'	12.0'	105'	19.0'
85'	13.0'	110'	20.0'

ASSEMBLY # SP PT HP LA GP T13904380 (MATERIAL FOR ONE UNIT ONLY)

PIECE / ASBY	QTY	UNIT DESCRIPTION	STOCK NO
E01500	3	EA HORZ POST POLYMERIC 18KV	01-09555
E04000	2	EA INSULATOR, STRAIN, FG, 54" 2X4	01-15510
N07204	50	FT STRAND GUY WIRE STEEL 7/16 HD	03-03107
N07303	4	EA PLATE POLE GUY 2X4	07-77698
N07309	4	EA CLEVIS THIMBLE	07-18459
N07704	6	EA GRIP GUY DEAD END 7/16"	07-45662
O01304	1	EA BOLT RACH GALV .685" x 18"	05-06003
O01309	1	EA BOLT RACH GALV .685" x 18"	05-05908
O01308	4	EA BOLT RACH GALV .750" x 10"	05-07400
O01370	4	EA BOLT RACH GALV .750" x 14"	05-07424
O01407	2	EA BOLT RACH GALV .075" x 10"	05-07997
O01409	4	EA BOLT RACH GALV .075" x 10"	05-07952
O01411	4	EA BOLT RACH GALV .075" x 20"	05-07969
O01413	2	EA BOLT RACH GALV .075" x 20"	05-07970
O02103	1	EA BOLT DBL RACH GALV .685" x 18"	05-07574
O02104	2	EA BOLT DBL RACH GALV .750" x 10"	05-07505
O02110	1	EA BOLT DBL RACH GALV .750" x 10"	05-07505
O02117	2	EA BOLT DBL RACH GALV .750" x 14"	05-07505
O02119	4	EA BOLT DBL RACH GALV .750" x 10"	05-07505
O02119	2	EA BOLT DBL RACH GALV .750" x 10"	05-07574
O02804	4	EA WASHER CURVED 3/4" x 7/8" BOLT	05-15705
O02809	1	EA WASHER CURVED 4/4" x 25 BOLT	05-15700
O07100	2	EA WASHER GALV 5/8" x 2.25" x .188	05-15629
O07202	1	EA WASHER GALV 5/8" x 2.25" x .188	05-15629
O07204	2	EA WASHER LOCK .075" DBL SPRING	05-16200
O07505	1	EA NUT EYE GALV .685"	05-02671
O07600	1	EA NUT EYE GALV .750"	05-02600
O07605	1	EA NUT LOCK GALV 50 .685"	05-02657
O07607	10	EA NUT LOCK GALV 50 .750"	05-02605
O07608	6	EA NUT LOCK GALV 50 .075"	05-02678

NOTES
 1 - ANY ITEM ASSEMBLED WITH A COTTER KEY IS TO BE INSTALLED SO THE COTTER KEY CAN BE INSPECTED FROM THE STRUCTURE.

REFERENCES
 GROUNDING INSTRUCTIONS - ETCLS, SECTION 7
 GUY AND ANCHOR INSTALLATION - ETCLS, SECTION 12

FORM SCALE = 24
 PLOTTING SCALE = 2
 DRAWING SCALE : 1/2" = 1'-0"

PAGE 15-38	TRANSMISSION LINE CONSTRUCTION STANDARDS	DEC 1999
------------	--	----------

DETAIL A
BONDING AT LOWER 3 GUY POSITIONS

CONDUCTOR DETAIL
REFER TO SECTION 9
138 KV CONDUCTOR ASSEMBLIES
FIGURE 10

GROUND WIRE DETAILS
REFER TO SECTION 10
138 KV GROUND WIRE ASSEMBLIES
FIGURE 8

ITEM NO.	QTY	DESCRIPTION	STOCK NO.
1	1	POLE-ANSI-REFER TO CONSTR LIST FOR CLASS, FIG 40(PG. 13-47)	06-----
2	2	3/4" x 12" OR 1 1/2" GALV DA BOLT	05-07541
3	2	3/4" x 12" OR 1 1/2" GALV SHOULDER EYEBOLT	05-11527
4	4	PER ITEM 2 (PAGE 14-55)	05-11543
5	4	3/4" x 1 1/2" OR 1 1/2" GALV SHOULDER EYEBOLT	05-11543
6	6	SQUARE NUT FOR 3/4" BOLT	05-42282
7	6	3/4" SQ CONCAVE - WF GALV LOCKNUT	05-42365
8	2	2-1/4" SQ GALV WASHER - 1 3/16" DIA HOLE	05-76652
9	6	#6 SOLID BARE COPPER WIRE (FOR BONDING)	08-32048
10	2	3/4" GALV EYEBOLT	05-42589
11	6	GALV BONDING CLIP FOR 3/4" BOLT	05-77817

NOTES
1 - ANY ITEM ASSEMBLED WITH A COTTER KEY IS TO BE INSTALLED SO THE COTTER KEY CAN BE INSPECTED FROM THE STRUCTURE.

REFERENCES
GROUNDING INSTRUCTIONS - SECTION 7
GUY AND ANCHOR INSTALLATION - SECTION 12

DWS NUMBER TL00AIA	CODE 78
-----------------------	------------

HEAVY DOUBLE DEAD END STRUCTURE (SINGLE POLE LINES)

APPROVED RG COTTRELL DATE 9-30-99

Dwg No.
TL0019202-E

Rev Sh
G 1

REV	DATE	DESCRIPTION	BY	APP

REV	DATE	DESCRIPTION	BY	APP
F	5/25/99	CHANGED INSULATORS TO NEW POLYMERIC INSULATORS	SSN	
G	9-30-99	CHGD STOCK NUMBERS, REMOVED ITEM 9, & CHCD FIGURE 6	DWH	

POLE LENGTH	DEPTH	POLE LENGTH	DEPTH
50'	7.0'	90'	11.0'
55'	7.5'	95'	11.0'
60'	8.0'	100'	11.0'
65'	8.5'	105'	12.0'
70'	9.0'	110'	12.0'
75'	9.5'	115'	12.0'
80'	10.0'	120'	12.0'
85'	10.5'	125'	12.0'

DWH
9-30-99

Pole# 218

FORM SCALE = 24
 PLOTTING SCALE = 2
 DRAWING SCALE : 1/2" = 1'-0"

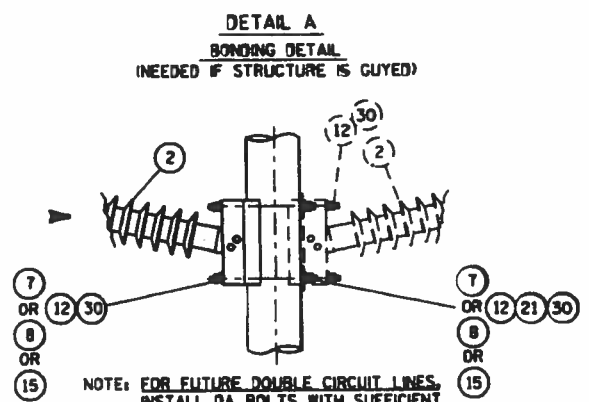
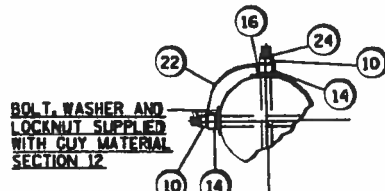
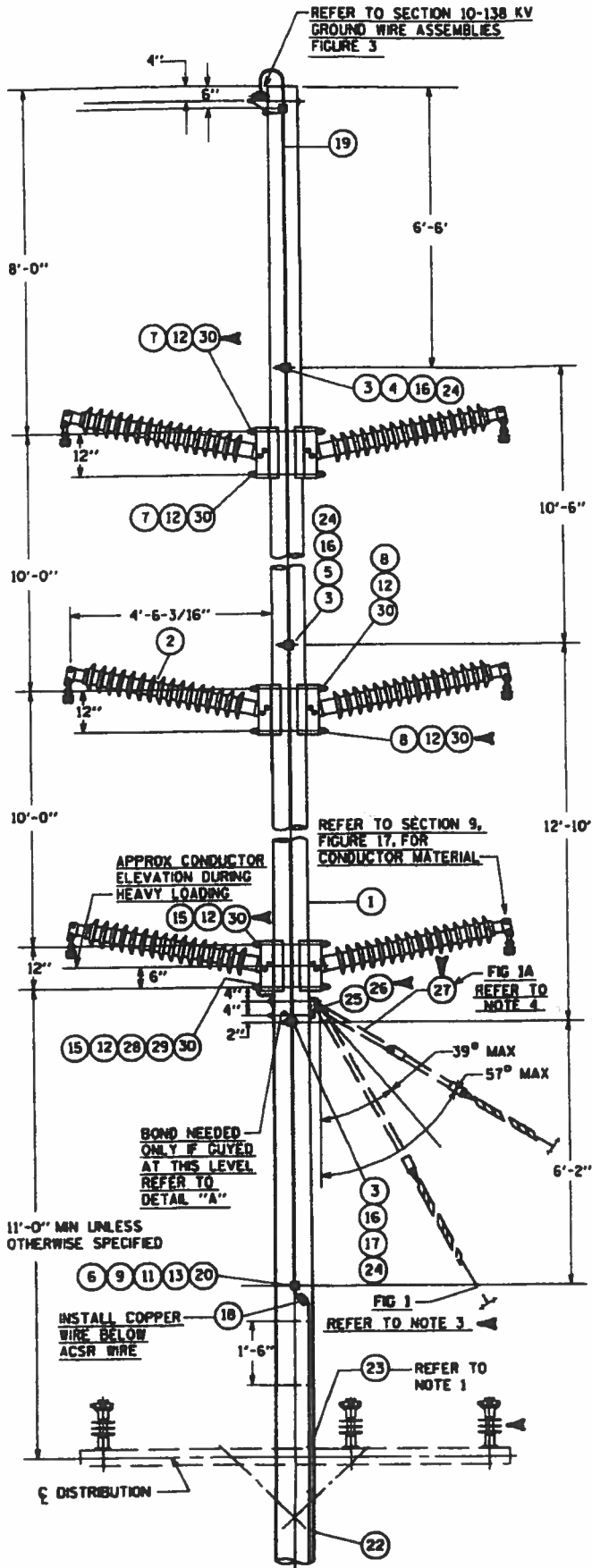

DEPTH OF SETTING			
POLE LENGTH	DEPTH	POLE LENGTH	DEPTH
50'	7.0'	80'	11.0'
55'	7.5'	85'	11.5'
60'	8.0'	90'	11.5'
65'	8.5'	95'	12.0'
70'	9.0'	100'	12.0'
75'	9.5'	105'	12.0'
80'	10.0'	110'	12.0'
85'	10.5'	115'	12.0'

MATERIAL SHOWN FOR DOUBLE CIRCUIT LINES - WHERE ONLY ONE CIRCUIT IS INSTALLED OMIT THREE CONDUCTOR ASSEMBLIES, REFER TO WIRE ARRANGEMENT FOR CONDUCTOR POSITIONS AND CONSTRUCTION LIST FOR GUYING

ITEM No.	QTY REQ'D	DESCRIPTION	STOCK No.
1	1	POLE-ANSI 05.1 - REFER TO CONSTR LIST FOR CLASS	06-01-89555
2	6	138 KV POLY LINE POST INSULATOR, LSK MDC	07-07661
3	3	FIBERGLASS DOWN LEAD BRACKET, (PG 14-52)	
4	1	3/4" X 14" OR 16" GALV MACH BOLT	05-27424
5	1	3/4" X 16" OR 18" GALV MACH BOLT	05-27440
6	1	3/8" X 18" OR 20" GALV MACH BOLT	05-27465
7	2	1/8" X 24" OR 26" GALV DA BOLT	05-26988
8	2	1/8" X 28" OR 28" GALV DA BOLT	05-07458
9	1	SQUARE NUT FOR 5/8" BOLT	05-07475
10	2	SQUARE NUT FOR 3/4" BOLT	05-42274
11	1	5/8" SQUARE CONCAVE - MF GALV LOCKNUT	05-42282
12	12	1/8" SQUARE CONCAVE - MF GALV LOCKNUT	05-42357
13	2	2" 50 GALV WASHER - 11/16" DIA HOLE	05-42373
14	2	GALV BONDING CLIP FOR 3/4" BOLT	05-76639
15	2	1/2" X 28" OR 30" GALV DA BOLT	05-77817
16	6	2 1/4" 50 GALV WASHER - 13/16" DIA HOLE	05-07475
17	1	3/4" X 18" OR 20" GALV MACH BOLT	05-76652
18	1	PG CLAMP - *4 ACSR TO *6 COPPER	05-27465
19	-	*4 ACSR WIRE IDOWN LEAD	05-27481
20	1	GALV BONDING CLIP FOR 5/8" BOLT	10-20114
21	6	4" 50 GALV CURVED STUBBING WASHER 15/16" DIA HOLE	06-30539
22	-	*6 BARE SOLID COPPER WIRE IDOWN LEAD AND/OR BONDING	05-77809
23	32 ±	GALV STAPLES (1-1/2")	05-76789
24	4	3/4" SQUARE CONCAVE - MF GALV LOCKNUT	07-80521
25	1	3/4" X 2" GALV MACH BOLT WITH HEX NUT	05-42355
26	1	3/4" GALV LOCK PALMUT	05-22292
27	2	GALV EXTENSION STRAP PER ITEM 3 - L = 2'-0", (PG 12-61)	05-41536
28	1	GALV BONDING CLIP FOR 1/8" BOLT	07-89982
29	1	SQUARE NUT FOR 1/8" BOLT	06-77825
30	12	ELEC MATERIAL TYPE 16-8 DBL COIL SPRING LOCKWASHER - 15/16" DIA HOLE	05-42290
			05-91636

- NOTES
- 1 - INSTALL ADDITIONAL STAPLES AS REQUIRED TO MAKE GROUNDING WIRE CONFORM TO IRREGULAR SURFACES OF POLE.
 - 2 - ANY ITEM ASSEMBLED WITH A COTTER KEY IS TO BE INSTALLED SO THE COTTER KEY CAN BE INSPECTED FROM THE STRUCTURE.
 - 3 - FIG. 1 - NO STRAPS ARE NEEDED ON GUYS UP TO 39', THE CONSTRUCTION LIST WILL SPECIFY FIG. 1A WHEN THIS TYPE OF GUY IS REQUIRED.
 - 4 - FIG. 1A - INSTALL (2) 2'-0" EXTENSION STRAPS (ITEM 27) BETWEEN FIBERGLASS GUY INSULATOR AND PLATE IF GUY IS FROM 39' TO 57'. THE CONSTRUCTION LIST WILL SPECIFY FIG. 1A WHEN THIS TYPE OF GUY IS REQUIRED.

REFERENCES
 GROUNDING INSTRUCTIONS - SECTION 7
 GUY AND ANCHOR INSTALLATION - SECTION 12

DESIGNED	CHKD
TTLOOAGX	78



138 KV HORIZONTAL POST TANGENT STRUCTURE
 PRESENT SINGLE CIRCUIT - FUTURE DOUBLE CIRCUIT OR DOUBLE CIRCUIT - 300' RULING SPAN DESIGN

APPROVED RG COTTRELL DATE 6-11-04 Dwg No. TLO019251-E Rev H Sh 1

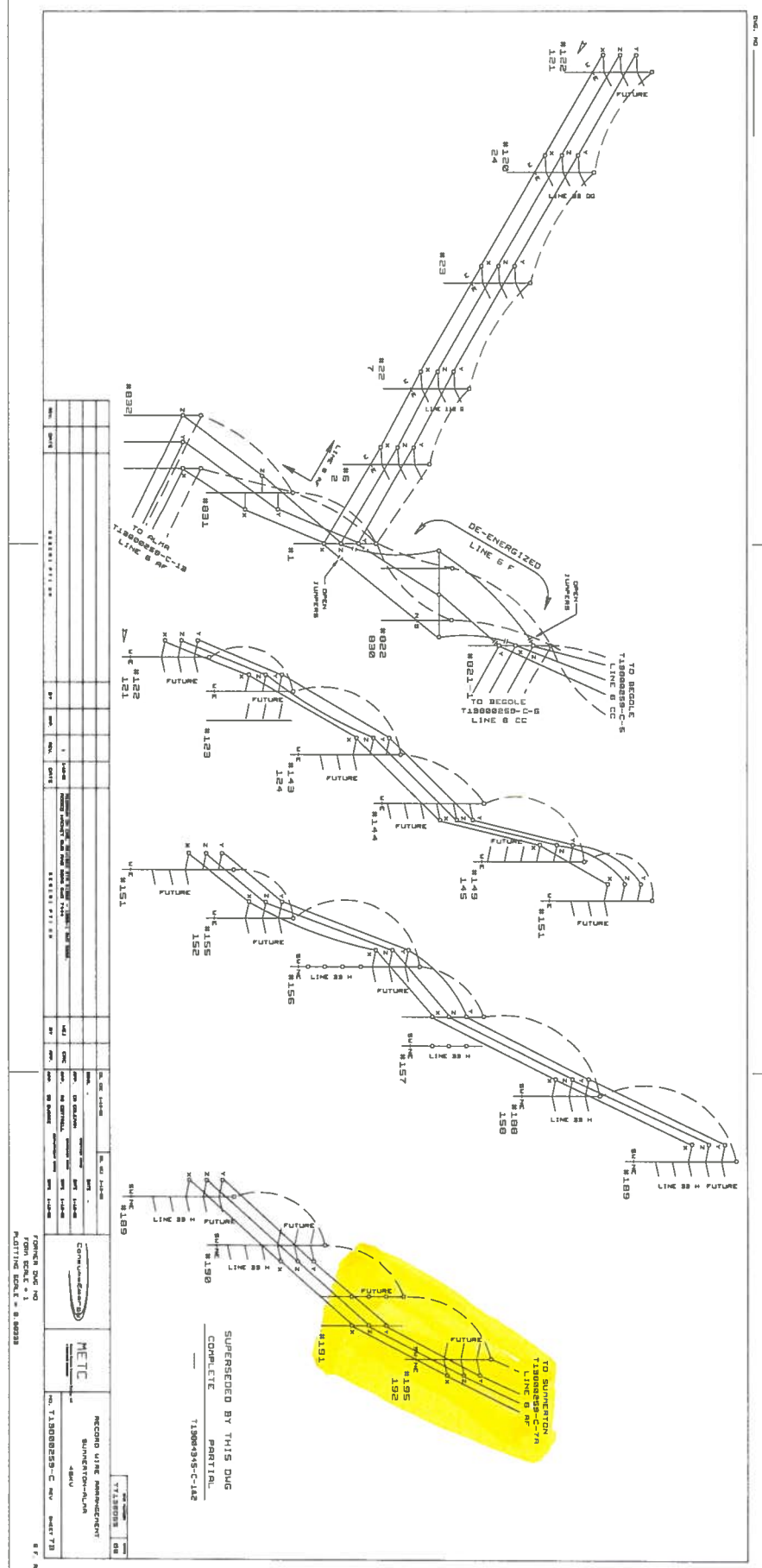

RECORD SHEET RECORD SHEET NO. T18000250-C-1A2 SHEET NO. 1 OF 1	
PROJECT NO. T18000250-C-1A2 PROJECT NAME: ...	
DRAWING NO. T18000250-C-1A2 DRAWING NAME: ...	
DATE: 5/4/2006 TIME: 01:34:09 PM	
DESIGNER: ... CHECKED: ... APPROVED: ...	
TITLE: ...	
SCALE: ...	
SHEET NO. 1 OF 1	

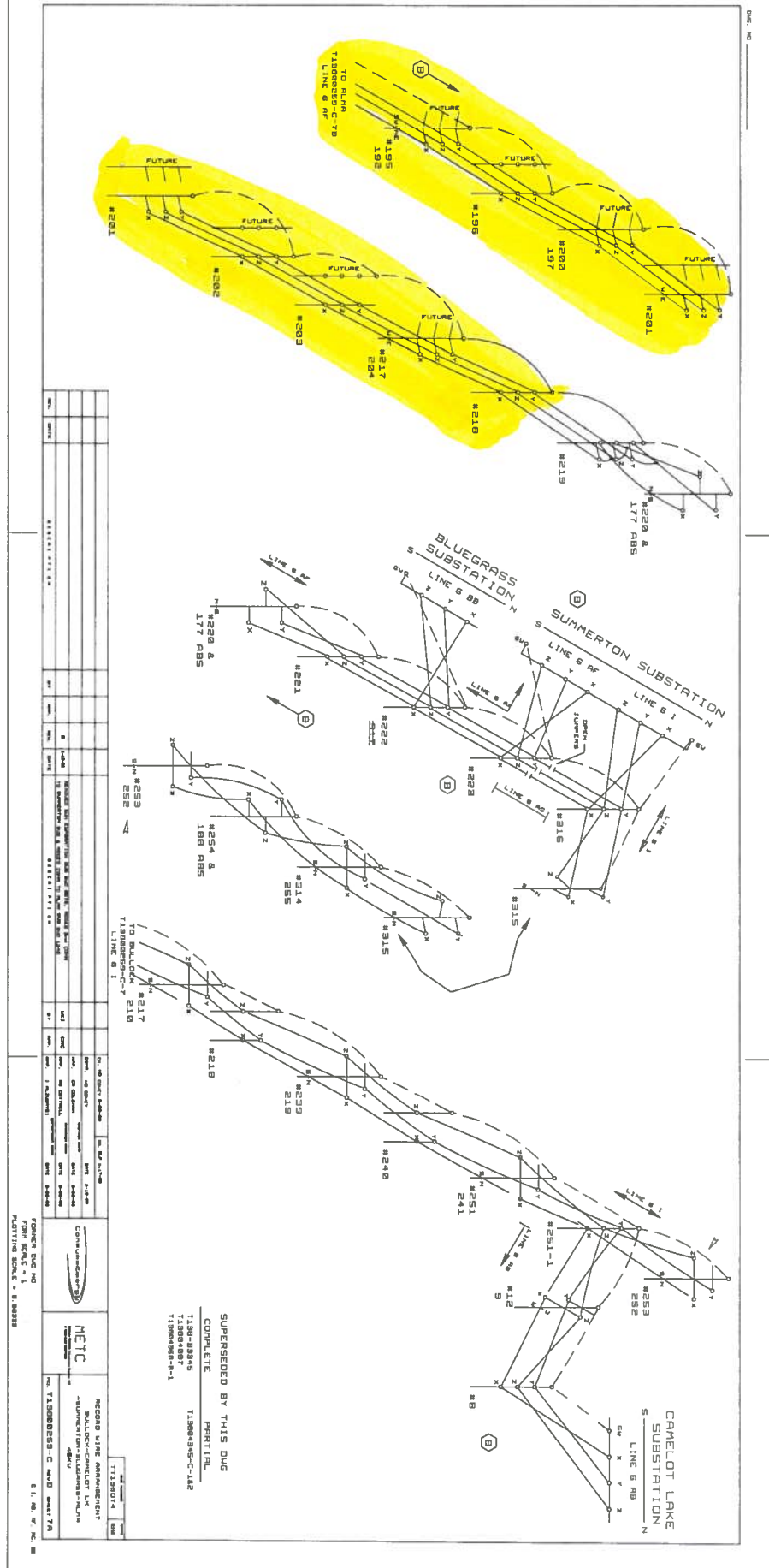

NO.	DATE	BY	DESCRIPTION	CHKD.	DATE	BY	DESCRIPTION
1	5/4/06
2
3
4
5
6
7
8
9
10

SUPERSEDED BY THIS DWG
 COMPLETE PARTIAL
 T1300-2346 T1300-435-C-1A2
 T1300-2346 T1300-435-C-1A2
 T1300-2346 T1300-435-C-1A2

FROM: DUC 10
 REVISION SCALE: 1/8"=1'-0"
 PROJECT SCALE: 1/8"=1'-0"
 T1300-435-C-1A2

RECORD LINE ASSIGNMENT
 BLUEGRASS-CAMELOT LK
 SUMMERTON-BALLOON-OLIVE
 CAMELOT LK
 T1300-435-C-1A2

LINE NAME : ALMA-SUMMERTON

UNIQUE STRUCT #: M0106602 ORDER : 213

LINE NO/LTR:	006AF
STRUCT #:	191
OP VOLTAGE:	138
STN/EQ :	607.83
BACK SPAN:	309.00
TYPE:	MULTI POLE
CONST TYPE:	PO

STRUCTURE

DWG: T13804381 SH: REV: LOC: 1 2 3 4 5 FIG:

REMARKS: USE CRUSHED ROCK BACKFILL.

LOC HEIGHT CLASS DEFLECT. G/L ELEV SETTING ELEV GUYING:
1 95 H1 21-35'-00" LT NO RAKE, BUTT 2' WEST OF CL

2 95 H1 NO RAKE, BUTT 12' EAST OF CL
2-7/16" EHS DN 35 & 30' E TO SS-PISA, 8 SP & 2 GUY GUARDS PER ANC

CONDUCTORS

LINE 006AF CKT 1
 SIZE 1 & 2: 336.4 KCMIL ACSR
 DES VOLTAGE: SH FIG REV SH FIG REV
 DWG: TL0019035 1 2
 SAG DWG: T13804372
 JMPR STR DWG:
 DAMPERS DWG:
 SPACER DWG #:
 SPACER RMKS:
 REMARKS:
 CKT 1:
 SAG CHART 336.4 KCMIL ACSR PER T13804372, 324'RS, 4280#MT

CENTERLINE ELEV:			
FRAMING			
SH	FIG	REV	
1:			
2:			
3:			
4:			
5:			
POLE STAY			
SH	FIG	REV	
1:			
2:			
3:			
4:			
5:			
SWAMP FIXT			
SH	FIG	REV	
1:			
2:			
3:			
4:			
5:			

CKT 2:

GROUND WIRE

LINE 006AF CKT 1
 SIZE: 80 KCMIL ACSR SH FIG REV SH FIG REV
 DWG NO: TL0019081 1 5
 SAG DWG: T13804371
 DAMPERS DWG:
 REMARKS:
 CKT 1:
 SAG CHART 80 KCMIL ACSR PER T13804371, 324'RS, 2050#MT.

PLAN & PROFILE		
DWG:	FIG:	REV:
SH:	FIG:	REV:
RWA		
DWG:	FIG:	REV:
SH:	FIG:	REV:
CWA		
DWG: T13804345	FIG:	REV:
SH:	FIG:	REV:
LIGHTNING ARRESTOR		

CKT 2:

GENERAL REMARKS

607.35 - MILLBROOK RD

STRUCTURE LOCATION

PROP OWNER:
PARCEL NO:
REMARKS:

TYPE OF RIGHT-OF-WAY:

COUNTY: ISABELLA
TOWNSHIP: CHIPPEWA
TOWN/RANGE: T14N,R03W
SECTION: 31

REVISION

LETTER: MWO NO:
 GWO: 1242 DATE: 6/9/2000
 RS NO: 45116 DESIGNER: KDK
 NOTES: NEW CONSTR LIST LINE 6AF - ADDED POLES FOR LINE

PREPARED BY: KDKING
 DATE: 6/9/2000
 APPROVED BY: CRCOLEMAN
 DATE: 6/9/2000
 DEPT. HEAD: BD BUGBEE
 DIVISION HEAD: RG COTTRELL

LINE NO/LTR: 006AF
 STR ORDER : 213
 STRUCT #: 191

LINE NAME : ALMA-SUMMERTON

UNIQUE STRUCT #: W0106603 ORDER : 214

LINE NO/LTR:	006AF
STRUCT #:	192
OP VOLTAGE:	138
STNEQ :	610.98
BACK SPAN:	315.00
DEFLECTION:	
TYPE:	WOOD POLE
POLE HT:	85
POLE CLASS:	2
CONST TYPE:	HP

STRUCTURE

DWG: TL0019251 SH: FIG: REV:

REMARKS: EXCEPT INSTALL INSULATORS ON NORTH SIDE OF POLES 192-195
USE CRUSHED ROCK BACKFILL.

GUYING:

CONDUCTORS

LINE 006AF CKT 1	LINE	CKT						
SIZE 1 & 2: 336.4 KCMIL ACSR								
DES VOLTAGE:	SH	FIG	REV			SH	FIG	REV
DWG: TL0019035	3	17						
SAG DWG: T13804372								
JMPR STR DWG:								
DAMPERS DWG:								
SPACER DWG #:								
SPACER RMKS:								

REMARKS:
CKT 1:
SAG CHART 336.4 KCMIL ACSR PER T13804372, 324'RS, 4280#MT

CKT 2:

ELEVATIONS

GROUNDLINE:
SETTING:
CENTERLINE:

FRAMING

POLE STAY

SWAMP FIXT

PLAN & PROFILE

DWG:
SH: FIG: REV:

RWA

DWG:
SH: FIG: REV:

CWA

DWG: T13804345
SH: FIG: REV:

LIGHTNING ARRESTOR

GROUND WIRE

LINE 006AF CKT 1	LINE	CKT						
SIZE: 80 KCMIL ACSR								
DWG NO: TL0019081	SH	FIG	REV			SH	FIG	REV
SAG DWG: T13804371	1	3						
DAMPERS DWG:								

REMARKS:
CKT 1:
SAG CHART 80 KCMIL ACSR PER T13804371, 324'RS, 2050#MT.

CKT 2:

GENERAL REMARKS

STRUCTURE LOCATION

PROP OWNER:
PARCEL NO:
REMARKS:

TYPE OF RIGHT-OF-WAY:

COUNTY: ISABELLA
TOWNSHIP: CHIPPEWA
TOWN/RANGE: T14N,R03W
SECTION: 31

REVISION

LETTER: MWO NO:
GWO: 1242 DATE: 6/9/2000
RS NO: 45116 DESIGNER: KDK
NOTES: NEW CONSTR LIST LINE 6AF - ADDED POLES FOR LINE

PREPARED BY: KDKING
DATE: 6/9/2000
APPROVED BY: CRCOLEMAN
DATE: 6/9/2000
DEPT. HEAD: BD BUGBEE
DIVISION HEAD: RG COTTRELL

LINE NO/LTR: 006AF
STR ORDER: 214
STRUCT #: 192

LINE NAME: ALMA-SUMMERTON

UNIQUE STRUCT #: W0106604 ORDER: 215

LINE NO/LTR:	006AF
STRUCT #:	193
OP VOLTAGE:	138
STN/EQ:	614.14
BACK SPAN:	316.00
DEFLECTION:	
TYPE:	WOOD POLE
POLE HT:	85
POLE CLASS:	2
CONST TYPE:	HP

STRUCTURE

DWG: TL0019251 SH: FIG: REV:

REMARKS: EXCEPT INSTALL INSULATORS ON NORTH SIDE OF POLES 192-195
USE CRUSHED ROCK BACKFILL.

GUYING:

CONDUCTORS

LINE 006AF CKT 1
 SIZE 1 & 2: 336.4 KCMIL ACSR
 DES VOLTAGE: SH FIG REV SH FIG REV
 DWG: TL0019035 3 17
 SAG DWG: T13804372
 JMPR STR DWG:
 DAMPERS DWG:
 SPACER DWG #:
 SPACER RMKS:

REMARKS:
CKT 1:
SAG CHART 336.4 KCMIL ACSR PER T13804372, 324'RS, 4280#MT

CKT 2:

ELEVATIONS

GROUNDLINE:
SETTING:
CENTERLINE:

FRAMING

POLE STAY

SWAMP FIXT

PLAN & PROFILE

DWG:
SH: FIG: REV:

RWA

DWG:
SH: FIG: REV:

CWA

DWG: T13804345
SH: FIG: REV:

LIGHTNING ARRESTOR

GROUND WIRE

LINE 006AF CKT 1
 SIZE: 80 KCMIL ACSR SH FIG REV SH FIG REV
 DWG NO: TL0019081 1 3
 SAG DWG: T13804371
 DAMPERS DWG:

REMARKS:
CKT 1:
SAG CHART 80 KCMIL ACSR PER T13804371, 324'RS, 2050#MT.

CKT 2:

GENERAL REMARKS

STRUCTURE LOCATION

PROP OWNER:
PARCEL NO:
REMARKS:

TYPE OF RIGHT-OF-WAY:

COUNTY: ISABELLA
TOWNSHIP: CHIPPEWA
TOWN/RANGE: T14N,R03W
SECTION: 31

REVISION

LETTER: MWO NO:
GWO: 1242 DATE: 6/9/2000
RS NO: 45116 DESIGNER: KDK
NOTES: NEW CONSTR LIST LINE 6AF - ADDED POLES FOR LINE

PREPARED BY: KDKING
DATE: 6/9/2000
APPROVED BY: CRCOLEMAN
DATE: 6/9/2000
DEPT. HEAD: BD BUGBEE
DIVISION HEAD: RG COTTRELL

LINE NO/LTR: 006AF
STR ORDER: 215
STRUCT #: 193

LINE NAME : ALMA-SUMMERTON

UNIQUE STRUCT #: W0106605 ORDER : 216

LINE NO/LTR:	006AF
STRUCT #:	194
OP VOLTAGE:	138
STN/EQ :	617.30
BACK SPAN:	316.00
DEFLECTION:	
TYPE:	WOOD POLE
POLE HT:	85
POLE CLASS:	2
CONST TYPE:	HP

STRUCTURE

DWG: TL0019251 SH: FIG: REV:

REMARKS: EXCEPT INSTALL INSULATORS ON NORTH SIDE OF POLES 192-195
USE CRUSHED ROCK BACKFILL.

GUYING:

CONDUCTORS

LINE 006AF CKT 1
 SIZE 1 & 2: 336.4 KCMIL ACSR
 DES VOLTAGE: SH FIG REV SH FIG REV
 DWG: TL0019035 3 17
 SAG DWG: T13804372
 JMPR STR DWG:
 DAMPERS DWG:
 SPACER DWG #:
 SPACER RMKS:

REMARKS:
CKT 1:
SAG CHART 336.4 KCMIL ACSR PER T13804372, 324'RS, 4280#MT

CKT 2:

ELEVATIONS

GROUNDLINE:
SETTING:
CENTERLINE:

FRAMING

POLE STAY

SWAMP FIXT

PLAN & PROFILE

DWG:
SH: FIG: REV:

RWA

DWG:
SH: FIG: REV:

GROUND WIRE

LINE 006AF CKT 1
 SIZE: 80 KCMIL ACSR SH FIG REV SH FIG REV
 DWG NO: TL0019081 1 3
 SAG DWG: T13804371
 DAMPERS DWG:

REMARKS:
CKT 1:
SAG CHART 80 KCMIL ACSR PER T13804371, 324'RS, 2050#MT.

CKT 2:

CWA

DWG: T13804345
SH: FIG: REV:

LIGHTNING ARRESTOR

GENERAL REMARKS

STRUCTURE LOCATION

PROP OWNER:
PARCEL NO:
REMARKS:

TYPE OF RIGHT-OF-WAY:

COUNTY: ISABELLA
TOWNSHIP: CHIPPEWA
TOWN/RANGE: T14N,R03W
SECTION: 31

REVISION

LETTER: MWO NO:
GWO: 1242 DATE: 6/9/2000
RS NO: 45116 DESIGNER: KDK
NOTES: NEW CONSTR LIST LINE 6AF - ADDED POLES FOR LINE

PREPARED BY: KDKING
DATE: 6/9/2000
APPROVED BY: CRCOLEMAN
DATE: 6/9/2000
DEPT. HEAD: BD BUGBEE
DIVISION HEAD: RG COTTRELL

LINE NO/LTR: 006AF
STR ORDER: 216
STRUCT #: 194

LINE NAME : ALMA-SUMMERTON

UNIQUE STRUCT #: W0106606 ORDER : 217

LINE NO/LTR:	006AF
STRUCT #:	195
OP VOLTAGE:	138
STN/EQ :	620.46
BACK SPAN:	316.00
DEFLECTION:	
TYPE:	WOOD POLE
POLE HT:	85
POLE CLASS:	2
CONST TYPE:	HP

STRUCTURE

DWG: TL0019251 SH: FIG: REV:

REMARKS: EXCEPT INSTALL INSULATORS ON NORTH SIDE OF POLES 192-195
USE CRUSHED ROCK BACKFILL.

GUYING:

CONDUCTORS

LINE 006AF CKT 1
 SIZE 1 & 2: 336.4 KCMIL ACSR
 DES VOLTAGE: SH FIG REV SH FIG REV
 DWG: TL0019035 3 17
 SAG DWG: T13804372
 JMPR STR DWG:
 DAMPERS DWG:
 SPACER DWG #:
 SPACER RMKS:

REMARKS:
CKT 1:
SAG CHART 336.4 KCMIL ACSR PER T13804372, 324'RS, 4280#MT

CKT 2:

ELEVATIONS

GROUNDLINE:
SETTING:
CENTERLINE:

FRAMING

POLE STAY

SWAMP FIXT

PLAN & PROFILE

DWG:
SH: FIG: REV:

RWA

DWG:
SH: FIG: REV:

CWA

DWG: T13804345
SH: FIG: REV:

LIGHTNING ARRESTOR

GROUND WIRE

LINE 006AF CKT 1
 SIZE: 80 KCMIL ACSR SH FIG REV SH FIG REV
 DWG NO: TL0019081 1 3
 SAG DWG: T13804371
 DAMPERS DWG:

REMARKS:
CKT 1:
SAG CHART 80 KCMIL ACSR PER T13804371, 324'RS, 2050#MT.

CKT 2:

GENERAL REMARKS

STRUCTURE LOCATION

PROP OWNER:
PARCEL NO:
REMARKS:

TYPE OF RIGHT-OF-WAY:

COUNTY: ISABELLA
TOWNSHIP: CHIPPEWA
TOWN/RANGE: T14N,R03W
SECTION: 31

REVISION

LETTER: MWO NO:
GWO: 1242 DATE: 6/9/2000
RS NO: 45116 DESIGNER: KDK
NOTES: NEW CONSTR LIST LINE 6AF - ADDED POLES FOR LINE

PREPARED BY: KDKING
DATE: 6/9/2000
APPROVED BY: CRCOLEMAN
DATE: 6/9/2000
DEPT. HEAD: BD BUGBEE
DIVISION HEAD: RG COTTRELL

LINE NO/LTR: 006AF
STR ORDER: 217
STRUCT #: 195

LINE NAME : ALMA-SUMMERTON

UNIQUE STRUCT #: M0106607 ORDER : 218

LINE NO/LTR:	006AF
STRUCT #:	196
OP VOLTAGE:	138
STN/EQ :	623.64
BACK SPAN:	318.00
TYPE:	MULTI POLE
CONST TYPE:	DDE

STRUCTURE

DWG: T13804382 SH: REV: LOC: 1 2 3 4 5 FIG:

REMARKS: USE CRUSHED ROCK BACKFILL.

LOC HEIGHT CLASS DEFLECT. G/L ELEV SETTING ELEV GUYING:
1 90 H1 61-55'-00" RT NO RAKE, BUTT 7' NE OF CL.

2 95 H1 NO RAKE, BUTT 7' SW OF CL.
2-7/16" EHS DOWN 50 & 45' NW TO SS-PISA, 8 SP & 2 GUY GUARDS PER ANC,
4-7/16" EHS SPAN 58' S TO 35-1 STUB POLE,
2-7/16" EHS DOWN 28' & 23' S TO SS-PISA, 8 SP & 2 GUY GUARDS PER ANC.

CONDUCTORS

LINE 006AF CKT 1
SIZE 1 & 2: 336.4 KCMIL ACSR
DES VOLTAGE: SH FIG REV SH FIG REV
DWG: TL0019035 2 10
SAG DWG: T13804372
JMPR STR DWG:
DAMPERS DWG:
SPACER DWG #:
SPACER RMKS:

REMARKS:
CKT 1:
SAG CHART 336.4 KCMIL ACSR PER T13804372, 324'RS, 4280#MT

CKT 2:

CENTERLINE ELEV:

FRAMING SH FIG REV
1:
2:
3:
4:
5:

POLE STAY SH FIG REV
1:
2:
3:
4:
5:

SWAMP FIXT SH FIG REV
1:
2:
3:
4:
5:

GROUND WIRE

LINE 006AF CKT 1
SIZE: 80 KCMIL ACSR SH FIG REV SH FIG REV
DWG NO: TL0019081 1 6
SAG DWG: T13804371
DAMPERS DWG:

REMARKS:
CKT 1:
SAG CHART 80 KCMIL ACSR PER T13804371, 324'RS, 2050#MT.

CKT 2:

PLAN & PROFILE
DWG:
SH: FIG: REV:

RWA
DWG:
SH: FIG: REV:

CWA
DWG: T13804345
SH: FIG: REV:

LIGHTNING ARRESTOR

GENERAL REMARKS

623.02 - SUMMERTON RD

STRUCTURE LOCATION

PROP OWNER:
PARCEL NO:
REMARKS:

TYPE OF RIGHT-OF-WAY:
COUNTY: ISABELLA
TOWNSHIP: UNION
TOWN/RANGE: T14N,R04W
SECTION: 36

REVISION

LETTER: MWO NO:
GWO: 1242 DATE: 6/9/2000
RS NO: 45116 DESIGNER: KDK
NOTES: NEW CONSTR LIST LINE 6AF - ADDED POLES FOR LINE

PREPARED BY: KDKING
DATE: 6/9/2000
APPROVED BY: CRCOLEMAN
DATE: 6/9/2000
DEPT. HEAD: BD BUGBEE
DIVISION HEAD: RG COTTRELL

LINE NO/LTR:	006AF
STR ORDER :	218
STRUCT #:	196

LINE NAME : ALMA-SUMMERTON

UNIQUE STRUCT #: W0106608 ORDER : 219

LINE NO/LTR:	006AF
STRUCT #:	197
OP VOLTAGE:	138
STN/EQ :	626.23
BACK SPAN:	259.00
DEFLECTION:	
TYPE:	WOOD POLE
POLE HT:	85
POLE CLASS:	2
CONST TYPE:	HP

STRUCTURE

DWG: TL0019251 SH: FIG: REV:

REMARKS: EXCEPT INSTALL INSULATORS ON EAST SIDE OF POLES 197-200
USE CRUSHED ROCK BACKFILL.

GUYING:

CONDUCTORS

LINE	006AF	CKT	1	LINE	CKT	SH	FIG	REV
SIZE 1 & 2:	336.4	KCMIL	ACSR					
DES VOLTAGE:				SH	FIG	REV		
DWG:	TL0019035			3	17			
SAG DWG:	T13804372							
JMPR STR DWG:								
DAMPERS DWG:								
SPACER DWG #:								
SPACER RMKS:								

REMARKS:
CKT 1:
SAG CHART 336.4 KCMIL ASCR PER T13804372, 324'RS, 4280#MT

CKT 2:

ELEVATIONS

GROUNDLINE:
SETTING:
CENTERLINE:

FRAMING

POLE STAY

SWAMP FIXT

PLAN & PROFILE

DWG:
SH: FIG: REV:

RWA

DWG:
SH: FIG: REV:

CWA

DWG: T13804345
SH: FIG: REV:

LIGHTNING ARRESTOR

GROUND WIRE

LINE	006AF	CKT	1	LINE	CKT	SH	FIG	REV
SIZE:	80	KCMIL	ACSR	SH	FIG	REV		
DWG NO:	TL0019081			1	3			
SAG DWG:	T13804371							
DAMPERS DWG:								

REMARKS:
CKT 1:
SAG CHART 80 KCMIL ASCR PER T13804371, 324'RS, 2050#MT.

CKT 2:

GENERAL REMARKS

STRUCTURE LOCATION

PROP OWNER:
PARCEL NO:
REMARKS:

TYPE OF RIGHT-OF-WAY:

COUNTY: ISABELLA
TOWNSHIP: UNION
TOWN/RANGE: T14N,R04W
SECTION: 36

REVISION

LETTER:
GWO: 1242
RS NO: 45116
NOTES: NEW CONSTR LIST LINE 6AF - ADDED POLES FOR LINE

MWO NO:
DATE: 6/9/2000
DESIGNER: KDK

PREPARED BY: KDKING
DATE: 6/9/2000
APPROVED BY: CRCOLEMAN
DATE: 6/9/2000
DEPT. HEAD: BD BUGBEE
DIVISION HEAD: RG COTTRELL

LINE NO/LTR: 006AF
STR ORDER: 219
STRUCT #: 197

LINE NAME : ALMA-SUMMERTON

UNIQUE STRUCT #: W0106609 ORDER : 220

LINE NO/LTR:	006AF
STRUCT #:	198
OP VOLTAGE:	138
STN/EQ :	628.92
BACK SPAN:	269.00
DEFLECTION:	
TYPE:	WOOD POLE
POLE HT:	85
POLE CLASS:	2
CONST TYPE:	HP

STRUCTURE

DWG: TL0019251 SH: FIG: REV:

REMARKS: EXCEPT INSTALL INSULATORS ON EAST SIDE OF POLES 197-200
USE CRUSHED ROCK BACKFILL.

GUYING:

CONDUCTORS

LINE	006AF	CKT	1	LINE	CKT	SH	FIG	REV	SH	FIG	REV
SIZE 1 & 2:	336.4 KCMIL ACSR										
DES VOLTAGE:											
DWG:	TL0019035					3	17				
SAG DWG:	T13804372										
JMPR STR DWG:											
DAMPERS DWG:											
SPACER DWG #:											
SPACER RMKS:											

REMARKS:
CKT 1:
SAG CHART 336.4 KCMIL ACSR PER T13804372, 324'RS, 4280#MT

CKT 2:

ELEVATIONS

GROUNDLINE:
SETTING:
CENTERLINE:

FRAMING

POLE STAY

SWAMP FIXT

PLAN & PROFILE

DWG:
SH: FIG: REV:

RWA

DWG:
SH: FIG: REV:

GROUND WIRE

LINE	006AF	CKT	1	LINE	CKT	SH	FIG	REV	SH	FIG	REV
SIZE:	80 KCMIL ACSR										
DWG NO:	TL0019081					1	3				
SAG DWG:	T13804371										
DAMPERS DWG:											

REMARKS:
CKT 1:
SAG CHART 80 KCMIL ACSR PER T13804371, 324'RS, 2050#MT.

CKT 2:

CWA

DWG: T13804345
SH: FIG: REV:

LIGHTNING ARRESTOR

GENERAL REMARKS

STRUCTURE LOCATION

PROP OWNER:
PARCEL NO:
REMARKS:

TYPE OF RIGHT-OF-WAY:

COUNTY: ISABELLA
TOWNSHIP: UNION
TOWN/RANGE: T14N,R04W
SECTION: 36

REVISION

LETTER: MWO NO:
GWO: 1242 DATE: 6/9/2000
RS NO: 45116 DESIGNER: KDK
NOTES: NEW CONSTR LIST LINE 6AF - ADDED POLES FOR LINE

PREPARED BY: KDKING
DATE: 6/9/2000
APPROVED BY: CRCOLEMAN
DATE: 6/9/2000
DEPT. HEAD: BD BUGBEE
DIVISION HEAD: RG COTTRELL

LINE NO/LTR:	006AF
STR ORDER:	220
STRUCT #:	198

LINE NAME : ALMA-SUMMERTON

UNIQUE STRUCT #: W0106610 ORDER : 221

LINE NO/LTR:	006AF
STRUCT #:	199
OP VOLTAGE:	138
STN/EQ :	631.68
BACK SPAN:	276.00
DEFLECTION:	
TYPE:	WOOD POLE
POLE HT:	85
POLE CLASS:	2
CONST TYPE:	HP

STRUCTURE

DWG: TL0019251 SH: FIG: REV:

REMARKS: EXCEPT INSTALL INSULATORS ON EAST SIDE OF POLES 197-200
USE CRUSHED ROCK BACKFILL.

GUYING:

CONDUCTORS

LINE	006AF	CKT	1	LINE	CKT	SH	FIG	REV
SIZE 1 & 2:	336.4 KCMIL ACSR							
DES VOLTAGE:				SH	FIG	REV		
DWG:	TL0019035			3	17			
SAG DWG:	T13804372							
JMPR STR DWG:								
DAMPERS DWG:								
SPACER DWG #:								
SPACER RMKS:								

REMARKS:
CKT 1:
SAG CHART 336.4 KCMIL ACSR PER T13804372, 324'RS, 4280#MT

CKT 2:

ELEVATIONS

GROUNDLINE:
SETTING:
CENTERLINE:

FRAMING

POLE STAY

SWAMP FIXT

PLAN & PROFILE

DWG:
SH: FIG: REV:

RWA

DWG:
SH: FIG: REV:

CWA

DWG: T13804345
SH: FIG: REV:

LIGHTNING ARRESTOR

GROUND WIRE

LINE	006AF	CKT	1	LINE	CKT	SH	FIG	REV
SIZE:	80 KCMIL ACSR							
DWG NO:	TL0019081			SH	FIG	REV		
SAG DWG:	T13804371			1	3			
DAMPERS DWG:								

REMARKS:
CKT 1:
SAG CHART 80 KCMIL ACSR PER T13804371, 324'RS, 2050#MT.

CKT 2:

GENERAL REMARKS

STRUCTURE LOCATION

PROP OWNER:
PARCEL NO:
REMARKS:

TYPE OF RIGHT-OF-WAY:

COUNTY: ISABELLA
TOWNSHIP: UNION
TOWN/RANGE: T14N,R04W
SECTION: 36

REVISION

LETTER: MWO NO:
GWO: 1242 DATE: 6/9/2000
RS NO: 45116 DESIGNER: KDK
NOTES: NEW CONSTR LIST LINE 6AF - ADDED POLES FOR LINE

PREPARED BY: KDKING
DATE: 6/9/2000
APPROVED BY: CRCOLEMAN
DATE: 6/9/2000
DEPT. HEAD: BD BUGBEE
DIVISION HEAD: RG COTTRELL

LINE NO/LTR: 006AF
STR ORDER: 221
STRUCT #: 199

LINE NAME : ALMA-SUMMERTON

UNIQUE STRUCT #: W0106653 ORDER : 222

LINE NO/LTR:	006AF
STRUCT #:	200
OP VOLTAGE:	138
STN/EQ :	634.99
BACK SPAN:	331.00
DEFLECTION:	4-55'-00" LT
TYPE:	WOOD POLE
POLE HT:	85
POLE CLASS:	2
CONST TYPE:	HP

STRUCTURE

DWG: TL0019251 SH: FIG: REV:

REMARKS: EXCEPT INSTALL INSULATORS ON EAST SIDE OF POLES 197-200
USE CRUSHED ROCK BACKFILL. NO RAKE, BUTT ON CL.

GUYING: 2-7/16" EHS (ATTACH AT GW & 4' BELOW MIDDLE CONDUCTOR) SPAN 14' E TO
80-2 STUB (ATTACH AT 1 FT & 18 FT BELOW POLE TOP),
2-7/16" EHS DOWN 15' E TO SS-PISA, 7 SP & 2 GUY GUARDS

CONDUCTORS

LINE	006AF	CKT	1	LINE	CKT	SH	FIG	REV
SIZE 1 & 2:	336.4 KCMIL ACSR							
DES VOLTAGE:						SH	FIG	REV
DWG:	TL0019035					3	18	
SAG DWG:	T13804372							
JMPR STR DWG:								
DAMPERS DWG:								
SPACER DWG #:								
SPACER RMKS:								

REMARKS:
CKT 1:
SAG CHART 336.4 KCMIL ACSR PER T13804372, 324'RS, 4280#MT

CKT 2:

ELEVATIONS

GROUNDLINE:
SETTING:
CENTERLINE:

FRAMING

POLE STAY

SWAMP FIXT

PLAN & PROFILE

DWG:
SH: FIG: REV:

RWA

DWG:
SH: FIG: REV:

GROUND WIRE

LINE	006AF	CKT	1	LINE	CKT	SH	FIG	REV
SIZE:	80 KCMIL ACSR							
DWG NO:	TL0019081					SH	FIG	REV
SAG DWG:	T13804371					1	3	
DAMPERS DWG:								

REMARKS:
CKT 1:
SAG CHART 80 KCMIL ACSR PER T13804371, 324'RS, 2050#MT.

CKT 2:

CWA

DWG: T13804345
SH: FIG: REV:

LIGHTNING ARRESTOR

GENERAL REMARKS

STRUCTURE LOCATION

PROP OWNER:
PARCEL NO:
REMARKS:

TYPE OF RIGHT-OF-WAY:

COUNTY: ISABELLA
TOWNSHIP: UNION
TOWN/RANGE: T14N,R04W
SECTION: 36

REVISION

LETTER: MWO NO:
GWO: 1242 DATE: 6/9/2000
RS NO: 45116 DESIGNER: KDK
NOTES: NEW CONSTR LIST LINE 6AF - ADDED POLES FOR LINE

PREPARED BY: KDKING
DATE: 6/9/2000
APPROVED BY: CRCOLEMAN
DATE: 6/9/2000
DEPT. HEAD: BD BUGBEE
DIVISION HEAD: RG COTTRELL

LINE NO/LTR: 006AF
STR ORDER: 222
STRUCT #: 200

LINE NAME : ALMA-SUMMERTON

UNIQUE STRUCT #: M0106612 ORDER : 223

LINE NO/LTR:	006AF
STRUCT #:	201
OP VOLTAGE:	138
STN/EQ :	637.95
BACK SPAN:	296.00
TYPE:	MULTI POLE
CONST TYPE:	HP

STRUCTURE
 DWG: T13804380 SH: REV: LOC: 1 2 3 4 5
 FIG:

REMARKS: USE CRUSHED ROCK BACKFILL.

LOC HEIGHT CLASS DEFLECT. G/L ELEV SETTING ELEV GUYING:
 1 90 H1 8-20'-00" RT NO RAKE, BUTT 2' EAST OF CL.

2 90 H1 NO RAKE, BUTT 12' WEST OF CL.
 4-7/16" EHS DOWN 25' W TO SS-PISA, 7 SP, 2 GUY GUARDS

CONDUCTORS

LINE 006AF CKT 1
 SIZE 1 & 2: 336.4 KCMIL ACSR
 DES VOLTAGE: SH FIG REV SH FIG REV
 DWG: TL0019035 3 17
 SAG DWG: T13804372
 JMPR STR DWG:
 DAMPERS DWG:
 SPACER DWG #:
 SPACER RMKS:

REMARKS:
 CKT 1:
 SAG CHART 336.4 KCMIL ACSR PER T13804372, 324'RS, 4280#MT

CKT 2:

CENTERLINE ELEV:

FRAMING	SH	FIG	REV
1:			
2:			
3:			
4:			
5:			

POLE STAY	SH	FIG	REV
1:			
2:			
3:			
4:			
5:			

SWAMP FIXT	SH	FIG	REV
1:			
2:			
3:			
4:			
5:			

GROUND WIRE

LINE 006AF CKT 1
 SIZE: 80 KCMIL ACSR SH FIG REV SH FIG REV
 DWG NO: TL0019081 1 3
 SAG DWG: T13804371
 DAMPERS DWG:

REMARKS:
 CKT 1:
 SAG CHART 80 KCMIL ACSR PER T13804371, 324'RS, 2050#MT.

CKT 2:

PLAN & PROFILE	DWG:	FIG:	REV:
SH:			

RWA	DWG:	FIG:	REV:
SH:			

CWA	DWG: T13804345	FIG:	REV:
SH:			

LIGHTNING ARRESTOR			
---------------------------	--	--	--

GENERAL REMARKS

STRUCTURE LOCATION

PROP OWNER:
 PARCEL NO:
 REMARKS:

TYPE OF RIGHT-OF-WAY:
 COUNTY: ISABELLA
 TOWNSHIP: UNION
 TOWN/RANGE: T14N,R04W
 SECTION: 36

REVISION

LETTER: MWO NO:
 GWO: 1242 DATE: 6/9/2000
 RS NO: 45116 DESIGNER: KDK
 NOTES: NEW CONSTR LIST LINE 6AF - ADDED POLES FOR LINE

PREPARED BY: KDKING
 DATE: 6/9/2000
 APPROVED BY: CRCOLEMAN
 DATE: 6/9/2000
 DEPT. HEAD: BD BUGBEE
 DIVISION HEAD: RG COTTRELL

LINE NO/LTR: 006AF
 STR ORDER : 223
 STRUCT #: 201

LINE NAME : ALMA-SUMMERTON

UNIQUE STRUCT #: M0106613 ORDER : 224

LINE NO/LTR:	006AF
STRUCT #:	202
OP VOLTAGE:	138
STN/EQ :	641.53
BACK SPAN:	358.00
TYPE:	MULTI POLE
CONST TYPE:	PO

STRUCTURE

DWG: T13804381 SH: REV: LOC: 1 2 3 4 5 FIG:

REMARKS: USE CRUSHED ROCK BACKFILL.

LOC HEIGHT CLASS DEFLECT. G/L ELEV SETTING ELEV GUYING:
 1 95 H1 22-15'-00" RT NO RAKE, BUTT 2' EAST OF CL

2 95 H1 NO RAKE, BUTT 12' WEST OF CL
 2-7/16" EHS DOWN 35 & 30' WEST TO SS-PISA, 8 SP & 2 GUY GUARDS PER ANC

CONDUCTORS

LINE 006AF CKT 1
 SIZE 1 & 2: 336.4 KCMIL ACSR
 DES VOLTAGE: SH FIG REV SH FIG REV
 DWG: TL0019035 1 2
 SAG DWG: T13804372
 JMPR STR DWG:
 DAMPERS DWG:
 SPACER DWG #:
 SPACER RMKS:

REMARKS:
 CKT 1:
 SAG CHART 336.4 KCMIL ACSR PER T13804372, 324'RS, 4280#MT

CKT 2:

CENTERLINE ELEV:

FRAMING SH FIG REV

- 1:
- 2:
- 3:
- 4:
- 5:

POLE STAY SH FIG REV

- 1:
- 2:
- 3:
- 4:
- 5:

SWAMP FIXT SH FIG REV

- 1:
- 2:
- 3:
- 4:
- 5:

GROUND WIRE

LINE 006AF CKT 1
 SIZE: 80 KCMIL ACSR SH FIG REV SH FIG REV
 DWG NO: TL0019081 1 5
 SAG DWG: T13804371
 DAMPERS DWG:

REMARKS:
 CKT 1:
 SAG CHART 80 KCMIL ACSR PER T13804371, 324'RS, 2050#MT.

CKT 2:

PLAN & PROFILE

DWG:
 SH: FIG: REV:

RWA

DWG:
 SH: FIG: REV:

CWA

DWG: T13804345
 SH: FIG: REV:

LIGHTNING ARRESTOR

GENERAL REMARKS

639.02 - US-127 SB LANE
 640.35 - US-127 NB LANE

STRUCTURE LOCATION

PROP OWNER:
 PARCEL NO:
 REMARKS:

TYPE OF RIGHT-OF-WAY:

COUNTY: ISABELLA
 TOWNSHIP: UNION
 TOWN/RANGE: T14N,R04W
 SECTION: 36

REVISION

LETTER: MWO NO:
 GWO: 1242 DATE: 6/9/2000
 RS NO: 45116 DESIGNER: KDK
 NOTES: NEW CONSTR LIST LINE 6AF - ADDED POLES FOR LINE

PREPARED BY: KDKING
 DATE: 6/9/2000
 APPROVED BY: CRCOLEMAN
 DATE: 6/9/2000
 DEPT. HEAD: BD BUGBEE
 DIVISION HEAD: RG COTTRELL

LINE NO/LTR: 006AF
 STR ORDER : 224
 STRUCT #: 202

LINE NAME : ALMA-SUMMERTON

UNIQUE STRUCT #: M0106614 ORDER : 225

LINE NO/LTR:	006AF
STRUCT #:	203
OP VOLTAGE:	138
STN/EQ :	645.19
BACK SPAN:	366.00
TYPE:	MULTI POLE
CONST TYPE:	PO

STRUCTURE

DWG: T13804381 SH: REV: LOC: 1 2 3 4 5 FIG:

REMARKS: USE CRUSHED ROCK BACKFILL.

LOC HEIGHT CLASS DEFLECT. G/L ELEV SETTING ELEV GUYING:
1 95 H1 24-15'-00" LT NO RAKE, BUTT 2' WEST OF CL

2 100 H1 NO RAKE, BUTT 12' EAST OF CL
2-7/16" EHS DOWN 35 & 30' EAST TO SS-PISA, 8 SP & 2 GUY GUARDS PER ANC

CONDUCTORS

LINE 006AF CKT 1
 SIZE 1 & 2: 336.4 KCMIL ACSR
 DES VOLTAGE: SH FIG REV SH FIG REV
 DWG: TL0019035 1 2
 SAG DWG: T13804372
 JMPR STR DWG:
 DAMPERS DWG:
 SPACER DWG #:
 SPACER RMKS:

REMARKS:
CKT 1:
SAG CHART 336.4 KCMIL ACSR PER T13804372, 324'RS, 4280#MT

CKT 2:

CENTERLINE ELEV:

FRAMING SH FIG REV
 1:
 2:
 3:
 4:
 5:

POLE STAY SH FIG REV
 1:
 2:
 3:
 4:
 5:

SWAMP FIXT SH FIG REV
 1:
 2:
 3:
 4:
 5:

GROUND WIRE

LINE 006AF CKT 1
 SIZE: 80 KCMIL ACSR SH FIG REV SH FIG REV
 DWG NO: TL0019081 1 5
 SAG DWG: T13804371
 DAMPERS DWG:

REMARKS:
CKT 1:
SAG CHART 80 KCMIL ACSR PER T13804371, 324'RS, 2050#MT.

CKT 2:

PLAN & PROFILE

DWG: SH: FIG: REV:

RWA

DWG: SH: FIG: REV:

CWA

DWG: T13804345 SH: FIG: REV:

LIGHTNING ARRESTOR

GENERAL REMARKS

644.34 - SUMMERTON RD

STRUCTURE LOCATION

PROP OWNER:
PARCEL NO:
REMARKS:

TYPE OF RIGHT-OF-WAY:

COUNTY: ISABELLA
TOWNSHIP: CHIPPEWA
TOWN/RANGE: T14N,R03W
SECTION: 31

REVISION

LETTER: MWO NO:
GWO: 1242 DATE: 6/9/2000
RS NO: 45116 DESIGNER: KDK
NOTES: NEW CONSTR LIST LINE 6AF - ADDED POLES FOR LINE

PREPARED BY: KDKING
DATE: 6/9/2000
APPROVED BY: CRCOLEMAN
DATE: 6/9/2000
DEPT. HEAD: BD BUGBEE
DIVISION HEAD: RG COTTRELL

LINE NO/LTR:	006AF
STR ORDER :	225
STRUCT #:	203

LINE NAME : ALMA-SUMMERTON

UNIQUE STRUCT #: W0106615 ORDER : 226

LINE NO/LTR:	006AF
STRUCT #:	204
OP VOLTAGE:	138
STN/EQ :	647.91
BACK SPAN:	272.00
DEFLECTION:	
TYPE:	WOOD POLE
POLE HT:	85
POLE CLASS:	2
CONST TYPE:	HP

STRUCTURE

DWG: TL0019251 SH: FIG: REV:

REMARKS: EXCEPT INSTALL INSULATORS ON EAST SIDE OF POLES 204-217
USE CRUSHED ROCK BACKFILL.

GUYING:

CONDUCTORS

LINE	006AF	CKT	1	LINE	CKT	SH	FIG	REV	SH	FIG	REV
SIZE 1 & 2:	336.4 KCMIL ACSR										
DES VOLTAGE:						SH	FIG	REV	SH	FIG	REV
DWG:	TL0019035					3	17				
SAG DWG:	T13804372										
JMPR STR DWG:											
DAMPERS DWG:											
SPACER DWG #:											
SPACER RMKS:											

REMARKS:

CKT 1:
SAG CHART 336.4 KCMIL ACSR PER T13804372, 324'RS, 4280#MT

CKT 2:

ELEVATIONS

GROUNDLINE:
SETTING:
CENTERLINE:

FRAMING

POLE STAY

SWAMP FIXT

PLAN & PROFILE

DWG:
SH: FIG: REV:

RWA

DWG:
SH: FIG: REV:

CWA

DWG: T13804345
SH: FIG: REV:

LIGHTNING ARRESTOR

GROUND WIRE

LINE	006AF	CKT	1	LINE	CKT	SH	FIG	REV	SH	FIG	REV
SIZE:	80 KCMIL ACSR										
DWG NO:	TL0019081					SH	FIG	REV	SH	FIG	REV
SAG DWG:	T13804371					1	3				
DAMPERS DWG:											

REMARKS:

CKT 1:
SAG CHART 80 KCMIL ACSR PER T13804371, 324'RS, 2050#MT.

CKT 2:

GENERAL REMARKS

STRUCTURE LOCATION

PROP OWNER:
PARCEL NO:
REMARKS:

TYPE OF RIGHT-OF-WAY:

COUNTY: ISABELLA
TOWNSHIP: CHIPPEWA
TOWN/RANGE: T14N,R03W
SECTION: 31

REVISION

LETTER: MWO NO:
GWO: 1242 DATE: 6/9/2000
RS NO: 45116 DESIGNER: KDK
NOTES: NEW CONSTR LIST LINE 6AF - ADDED POLES FOR LINE

PREPARED BY: KDKING
DATE: 6/9/2000
APPROVED BY: CRCOLEMAN
DATE: 6/9/2000
DEPT. HEAD: BD BUGBEE
DIVISION HEAD: RG COTTRELL

LINE NO/LTR: 006AF
STR ORDER: 226
STRUCT #: 204

LINE NAME : ALMA-SUMMERTON

UNIQUE STRUCT #: W0106616 ORDER : 227

LINE NO/LTR:	006AF
STRUCT #:	205
OP VOLTAGE:	138
STN/EQ :	650.81
BACK SPAN:	290.00
DEFLECTION:	
TYPE:	WOOD POLE
POLE HT:	85
POLE CLASS:	2
CONST TYPE:	HP

STRUCTURE

DWG: TL0019251 SH: FIG: REV:

REMARKS: EXCEPT INSTALL INSULATORS ON EAST SIDE OF POLES 204-217
USE CRUSHED ROCK BACKFILL.

GUYING:

CONDUCTORS

LINE 006AF CKT 1
 SIZE 1 & 2: 336.4 KCMIL ACSR
 DES VOLTAGE: SH FIG REV SH FIG REV
 DWG: TL0019035 3 17
 SAG DWG: T13804372
 JMPR STR DWG:
 DAMPERS DWG:
 SPACER DWG #:
 SPACER RMKS:

REMARKS:

CKT 1:
SAG CHART 336.4 KCMIL ACSR PER T13804372, 324'RS, 4280#MT

CKT 2:

ELEVATIONS

GROUNDLINE:
SETTING:
CENTERLINE:

FRAMING

POLE STAY

SWAMP FIXT

PLAN & PROFILE

DWG:
SH: FIG: REV:

RWA

DWG:
SH: FIG: REV:

GROUND WIRE

LINE 006AF CKT 1
 SIZE: 80 KCMIL ACSR SH FIG REV SH FIG REV
 DWG NO: TL0019081 1 3
 SAG DWG: T13804371
 DAMPERS DWG:

REMARKS:

CKT 1:
SAG CHART 80 KCMIL ACSR PER T13804371, 324'RS, 2050#MT.

CKT 2:

CWA

DWG: T13804345
SH: FIG: REV:

LIGHTNING ARRESTOR

GENERAL REMARKS

STRUCTURE LOCATION

PROP OWNER:
PARCEL NO:
REMARKS:

TYPE OF RIGHT-OF-WAY:

COUNTY: ISABELLA
TOWNSHIP: CHIPPEWA
TOWN/RANGE: T14N,R03W
SECTION: 31

REVISION

LETTER: MWO NO:
GWO: 1242 DATE: 6/9/2000
RS NO: 45116 DESIGNER: KDK
NOTES: NEW CONSTR LIST LINE 6AF - ADDED POLES FOR LINE

PREPARED BY: KDKING
DATE: 6/9/2000
APPROVED BY: CRCOLEMAN
DATE: 6/9/2000
DEPT. HEAD: BD BUGBEE
DIVISION HEAD: RG COTTRELL

LINE NO/LTR: 006AF
STR ORDER: 227
STRUCT #: 205

LINE NAME : ALMA-SUMMERTON

UNIQUE STRUCT #: W0106617 ORDER: 228

LINE NO/LTR:	006AF
STRUCT #:	206
OP VOLTAGE:	138
STN/EQ :	653.64
BACK SPAN:	283.00
DEFLECTION:	
TYPE:	WOOD POLE
POLE HT:	85
POLE CLASS:	2
CONST TYPE:	HP

STRUCTURE

DWG: TL0019251 SH: FIG: REV:

REMARKS: EXCEPT INSTALL INSULATORS ON EAST SIDE OF POLES 204-217
USE CRUSHED ROCK BACKFILL.

GUYING:

CONDUCTORS

LINE 006AF CKT 1
 SIZE 1 & 2: 336.4 KCMIL ACSR
 DES VOLTAGE: SH FIG REV SH FIG REV
 DWG: TL0019035 3 17
 SAG DWG: T13804372
 JMPR STR DWG:
 DAMPERS DWG:
 SPACER DWG #:
 SPACER RMKS:

REMARKS:
CKT 1:
SAG CHART 336.4 KCMIL ACSR PER T13804372, 324'RS, 4280#MT

CKT 2:

ELEVATIONS

GROUNDLINE:
SETTING:
CENTERLINE:

FRAMING

POLE STAY

SWAMP FIXT

PLAN & PROFILE

DWG:
SH: FIG: REV:

RWA

DWG:
SH: FIG: REV:

CWA

DWG: T13804345
SH: FIG: REV:

LIGHTNING ARRESTOR

GROUND WIRE

LINE 006AF CKT 1
 SIZE: 80 KCMIL ACSR SH FIG REV SH FIG REV
 DWG NO: TL0019081 1 3
 SAG DWG: T13804371
 DAMPERS DWG:

REMARKS:
CKT 1:
SAG CHART 80 KCMIL ACSR PER T13804371, 324'RS, 2050#MT.

CKT 2:

GENERAL REMARKS

STRUCTURE LOCATION

PROP OWNER:
PARCEL NO:
REMARKS:

TYPE OF RIGHT-OF-WAY:

COUNTY: ISABELLA
TOWNSHIP: CHIPPEWA
TOWN/RANGE: T14N,R03W
SECTION: 31

REVISION

LETTER: MWO NO:
GWO: 1242 DATE: 6/9/2000
RS NO: 45116 DESIGNER: KDK
NOTES: NEW CONSTR LIST LINE 6AF - ADDED POLES FOR LINE

PREPARED BY: KDKING
DATE: 6/9/2000
APPROVED BY: CRCOLEMAN
DATE: 6/9/2000
DEPT. HEAD: BD BUGBEE
DIVISION HEAD: RG COTTRELL

LINE NO/LTR: 006AF
STR ORDER: 228
STRUCT #: 206

LINE NAME : ALMA-SUMMERTON

UNIQUE STRUCT #: W0106618 ORDER: 229

LINE NO/LTR:	006AF
STRUCT #:	207
OP VOLTAGE:	138
STN/EQ :	656.45
BACK SPAN:	281.00
DEFLECTION:	
TYPE:	WOOD POLE
POLE HT:	85
POLE CLASS:	2
CONST TYPE:	HP

STRUCTURE

DWG: TL0019251 SH: FIG: REV:

REMARKS: EXCEPT INSTALL INSULATORS ON EAST SIDE OF POLES 204-217
USE CRUSHED ROCK BACKFILL.

GUYING:

CONDUCTORS

LINE	006AF	CKT	1	LINE	CKT	SH	FIG	REV	SH	FIG	REV
SIZE 1 & 2:	336.4 KCMIL ACSR										
DES VOLTAGE:											
DWG:	TL0019035					3	17				
SAG DWG:	T13804372										
JMPR STR DWG:											
DAMPERS DWG:											
SPACER DWG #:											
SPACER RMKS:											

REMARKS:

CKT 1:
SAG CHART 336.4 KCMIL ACSR PER T13804372, 324'RS, 4280#MT

CKT 2:

ELEVATIONS

GROUNDLINE:
SETTING:
CENTERLINE:

FRAMING

POLE STAY

SWAMP FIXT

PLAN & PROFILE

DWG:
SH: FIG: REV:

RWA

DWG:
SH: FIG: REV:

GROUND WIRE

LINE	006AF	CKT	1	LINE	CKT	SH	FIG	REV	SH	FIG	REV
SIZE:	80 KCMIL ACSR										
DWG NO:	TL0019081					1	3				
SAG DWG:	T13804371										
DAMPERS DWG:											

REMARKS:

CKT 1:
SAG CHART 80 KCMIL ACSR PER T13804371, 324'RS, 2050#MT.

CKT 2:

CWA

DWG: T13804345
SH: FIG: REV:

LIGHTNING ARRESTOR

GENERAL REMARKS

STRUCTURE LOCATION

PROP OWNER:
PARCEL NO:
REMARKS:

TYPE OF RIGHT-OF-WAY:

COUNTY: ISABELLA
TOWNSHIP: CHIPPEWA
TOWN/RANGE: T14N,R03W
SECTION: 31

REVISION

LETTER: MWO NO:
GWO: 1242 DATE: 6/9/2000
RS NO: 45116 DESIGNER: KDK
NOTES: NEW CONSTR LIST LINE 6AF - ADDED POLES FOR LINE

PREPARED BY: KDKING
DATE: 6/9/2000
APPROVED BY: CRCOLEMAN
DATE: 6/9/2000
DEPT. HEAD: BD BUGBEE
DIVISION HEAD: RG COTTRELL

LINE NO/LTR:	006AF
STR ORDER:	229
STRUCT #:	207

LINE NAME : ALMA-SUMMERTON

UNIQUE STRUCT #: W0106619 ORDER : 230

LINE NO/LTR:	006AF
STRUCT #:	208
OP VOLTAGE:	138
STN/EQ :	659.87
BACK SPAN:	342.00
DEFLECTION:	
TYPE:	WOOD POLE
POLE HT:	85
POLE CLASS:	1
CONST TYPE:	HP

STRUCTURE

DWG: TL0019251 SH: FIG: REV:

REMARKS: EXCEPT INSTALL INSULATORS ON EAST SIDE OF POLES 204-217
USE CRUSHED ROCK BACKFILL.

GUYING:

CONDUCTORS

LINE	006AF	CKT	1	LINE	CKT	SH	FIG	REV	SH	FIG	REV
SIZE 1 & 2:	336.4 KCMIL ACSR										
DES VOLTAGE:						SH	FIG	REV			
DWG:	TL0019035					3	17				
SAG DWG:	T13804372										
JMPR STR DWG:											
DAMPERS DWG:											
SPACER DWG #:											
SPACER RMKS:											

REMARKS:
CKT 1:
SAG CHART 336.4 KCMIL ACSR PER T13804372, 324'RS, 4280#MT

CKT 2:

ELEVATIONS

GROUNDLINE:
SETTING:
CENTERLINE:

FRAMING

POLE STAY

SWAMP FIXT

PLAN & PROFILE

DWG:
SH: FIG: REV:

RWA

DWG:
SH: FIG: REV:

GROUND WIRE

LINE	006AF	CKT	1	LINE	CKT	SH	FIG	REV	SH	FIG	REV
SIZE:	80 KCMIL ACSR										
DWG NO:	TL0019081					SH	FIG	REV			
SAG DWG:	T13804371					1	3				
DAMPERS DWG:											

REMARKS:
CKT 1:
SAG CHART 80 KCMIL ACSR PER T13804371, 324'RS, 2050#MT.

CKT 2:

CWA

DWG: T13804345
SH: FIG: REV:

LIGHTNING ARRESTOR

GENERAL REMARKS

STRUCTURE LOCATION

PROP OWNER:
PARCEL NO:
REMARKS:

TYPE OF RIGHT-OF-WAY:

COUNTY: ISABELLA
TOWNSHIP: CHIPPEWA
TOWN/RANGE: T14N,R03W
SECTION: 31

REVISION

LETTER: MWO NO:
GWO: 1242 DATE: 6/9/2000
RS NO: 45116 DESIGNER: KDK
NOTES: NEW CONSTR LIST LINE 6AF - ADDED POLES FOR LINE

PREPARED BY: KDKING
DATE: 6/9/2000
APPROVED BY: CRCOLEMAN
DATE: 6/9/2000
DEPT. HEAD: BD BUGBEE
DIVISION HEAD: RG COTTRELL

LINE NO/LTR: 006AF
STR ORDER: 230
STRUCT #: 208

LINE NAME : ALMA-SUMMERTON

UNIQUE STRUCT #: W0106620 ORDER : 231

LINE NO/LTR:	006AF
STRUCT #:	209
OP VOLTAGE:	138
STN/EQ :	663.30
BACK SPAN:	343.00
DEFLECTION:	
TYPE:	WOOD POLE
POLE HT:	85
POLE CLASS:	1
CONST TYPE:	HP

STRUCTURE

DWG: TL0019251 SH: FIG: REV:

REMARKS: EXCEPT INSTALL INSULATORS ON EAST SIDE OF POLES 204-217
USE CRUSHED ROCK BACKFILL.

GUYING:

CONDUCTORS

LINE 006AF CKT 1	LINE	CKT					
SIZE 1 & 2: 336.4 KCMIL ACSR							
DES VOLTAGE:	SH	FIG	REV		SH	FIG	REV
DWG: TL0019035	3	17					
SAG DWG: T13804372							
JMPR STR DWG:							
DAMPERS DWG:							
SPACER DWG #:							
SPACER RMKS:							

REMARKS:
CKT 1:
SAG CHART 336.4 KCMIL ACSR PER T13804372, 324'RS, 4280#MT

CKT 2:

ELEVATIONS

GROUNDLINE:
SETTING:
CENTERLINE:

FRAMING

POLE STAY

SWAMP FIXT

PLAN & PROFILE

DWG:
SH: FIG: REV:

RWA

DWG:
SH: FIG: REV:

GROUND WIRE

LINE 006AF CKT 1	LINE	CKT					
SIZE: 80 KCMIL ACSR							
DWG NO: TL0019081	SH	FIG	REV		SH	FIG	REV
SAG DWG: T13804371	1	3					
DAMPERS DWG:							

REMARKS:
CKT 1:
SAG CHART 80 KCMIL ACSR PER T13804371, 324'RS, 2050#MT.

CKT 2:

CWA

DWG: T13804345
SH: FIG: REV:

LIGHTNING ARRESTOR

GENERAL REMARKS

STRUCTURE LOCATION

TYPE OF RIGHT-OF-WAY:

PROP OWNER:
PARCEL NO:
REMARKS:

COUNTY: ISABELLA
TOWNSHIP: CHIPPEWA
TOWN/RANGE: T14N,R03W
SECTION: 31

REVISION

LETTER: MWO NO:
GWO: 1242 DATE: 6/9/2000
RS NO: 45116 DESIGNER: KDK
NOTES: NEW CONSTR LIST LINE 6AF - ADDED POLES FOR LINE

PREPARED BY: KDKING
DATE: 6/9/2000
APPROVED BY: CRCOLEMAN
DATE: 6/9/2000
DEPT. HEAD: BD BUGBEE
DIVISION HEAD: RG COTTRELL

LINE NO/LTR: 006AF
STR ORDER: 231
STRUCT #: 209

LINE NAME : ALMA-SUMMERTON

UNIQUE STRUCT #: W0106621 ORDER : 232

LINE NO/LTR:	006AF
STRUCT #:	210
OP VOLTAGE:	138
STN/EQ :	666.71
BACK SPAN:	341.00
DEFLECTION:	
TYPE:	WOOD POLE
POLE HT:	85
POLE CLASS:	1
CONST TYPE:	HP

STRUCTURE

DWG: TL0019251 SH: FIG: REV:

REMARKS: EXCEPT INSTALL INSULATORS ON EAST SIDE OF POLES 204-217
USE CRUSHED ROCK BACKFILL.

GUYING:

CONDUCTORS

LINE 006AF CKT 1	LINE	CKT						
SIZE 1 & 2: 336.4 KCMIL ACSR								
DES VOLTAGE:	SH	FIG	REV			SH	FIG	REV
DWG: TL0019035	3	17						
SAG DWG: T13804372								
JMPR STR DWG:								
DAMPERS DWG:								
SPACER DWG #:								
SPACER RMKS:								

REMARKS:
CKT 1:
SAG CHART 336.4 KCMIL ACSR PER T13804372, 324'RS, 4280#MT

CKT 2:

ELEVATIONS

GROUNDLINE:
SETTING:
CENTERLINE:

FRAMING

POLE STAY

SWAMP FIXT

PLAN & PROFILE

DWG:
SH: FIG: REV:

RWA

DWG:
SH: FIG: REV:

CWA

DWG: T13804345
SH: FIG: REV:

LIGHTNING ARRESTOR

GROUND WIRE

LINE 006AF CKT 1	LINE	CKT						
SIZE: 80 KCMIL ACSR								
DWG NO: TL0019081	SH	FIG	REV			SH	FIG	REV
SAG DWG: T13804371	1	3						
DAMPERS DWG:								

REMARKS:
CKT 1:
SAG CHART 80 KCMIL ACSR PER T13804371, 324'RS, 2050#MT.

CKT 2:

GENERAL REMARKS

STRUCTURE LOCATION

PROP OWNER:
PARCEL NO:
REMARKS:

TYPE OF RIGHT-OF-WAY:

COUNTY: ISABELLA
TOWNSHIP: CHIPPEWA
TOWN/RANGE: T14N,R03W
SECTION: 31

REVISION

LETTER: MWO NO:
GWO: 1242 DATE: 6/9/2000
RS NO: 45116 DESIGNER: KDK
NOTES: NEW CONSTR LIST LINE 6AF - ADDED POLES FOR LINE

PREPARED BY: KDKING
DATE: 6/9/2000
APPROVED BY: CRCOLEMAN
DATE: 6/9/2000
DEPT. HEAD: BD BUGBEE
DIVISION HEAD: RG COTTRELL

LINE NO/LTR: 006AF
STR ORDER: 232
STRUCT #: 210

LINE NAME: ALMA-SUMMERTON

UNIQUE STRUCT #: W0106622 ORDER: 233

LINE NO/LTR:	006AF
STRUCT #:	211
OP VOLTAGE:	138
STN/EQ :	670.17
BACK SPAN:	346.00
DEFLECTION:	0-21'-00" RT
TYPE:	WOOD POLE
POLE HT:	85
POLE CLASS:	1
CONST TYPE:	HP

STRUCTURE

DWG: TL0019251 SH: FIG: REV:

REMARKS: EXCEPT INSTALL INSULATORS ON EAST SIDE OF POLES 204-217
USE CRUSHED ROCK BACKFILL. NO RAKE, BUTT ON CL.

GUYING:

CONDUCTORS

LINE 006AF CKT 1
 SIZE 1 & 2: 336.4 KCMIL ACSR
 DES VOLTAGE: SH FIG REV SH FIG REV
 DWG: TL0019035 3 17
 SAG DWG: T13804372
 JMPR STR DWG:
 DAMPERS DWG:
 SPACER DWG #:
 SPACER RMKS:

REMARKS:
CKT 1:
SAG CHART 336.4 KCMIL ACSR PER T13804372, 324'RS, 4280#MT

CKT 2:

ELEVATIONS

GROUNDLINE:
SETTING:
CENTERLINE:

FRAMING

POLE STAY

SWAMP FIXT

PLAN & PROFILE

DWG:
SH: FIG: REV:

RWA

DWG:
SH: FIG: REV:

CWA

DWG: T13804345
SH: FIG: REV:

LIGHTNING ARRESTOR

GROUND WIRE

LINE 006AF CKT 1
 SIZE: 80 KCMIL ACSR SH FIG REV SH FIG REV
 DWG NO: TL0019081 1 3
 SAG DWG: T13804371
 DAMPERS DWG:

REMARKS:
CKT 1:
SAG CHART 80 KCMIL ACSR PER T13804371, 324'RS, 2050#MT.

CKT 2:

GENERAL REMARKS

669.58 - DEERFIELD RD

STRUCTURE LOCATION

PROP OWNER:
PARCEL NO:
REMARKS:

TYPE OF RIGHT-OF-WAY:

COUNTY: ISABELLA
TOWNSHIP: CHIPPEWA
TOWN/RANGE: T14N,R03W
SECTION: 30

REVISION

LETTER: MWO NO:
GWO: 1242 DATE: 6/9/2000
RS NO: 45116 DESIGNER: KDK
NOTES: NEW CONSTR LIST LINE 6AF - ADDED POLES FOR LINE

PREPARED BY: KDKING
DATE: 6/9/2000
APPROVED BY: CRCOLEMAN
DATE: 6/9/2000
DEPT. HEAD: BD BUGBEE
DIVISION HEAD: RG COTTRELL

LINE NO/LTR: 006AF
STR ORDER: 233
STRUCT #: 211

LINE NAME : ALMA-SUMMERTON

UNIQUE STRUCT #: W0106623 ORDER : 234

LINE NO/LTR:	006AF
STRUCT #:	212
OP VOLTAGE:	138
STN/EQ :	673.33
BACK SPAN:	316.00
DEFLECTION:	
TYPE:	WOOD POLE
POLE HT:	85
POLE CLASS:	2
CONST TYPE:	HP

STRUCTURE

DWG: TL0019251 SH: FIG: REV:

REMARKS: EXCEPT INSTALL INSULATORS ON EAST SIDE OF POLES 204-217
USE CRUSHED ROCK BACKFILL.

GUYING:

CONDUCTORS

LINE 006AF CKT 1
 SIZE 1 & 2: 336.4 KCMIL ACSR
 DES VOLTAGE: SH FIG REV SH FIG REV
 DWG: TL0019035 3 17
 SAG DWG: T13804372
 JMPR STR DWG:
 DAMPERS DWG:
 SPACER DWG #:
 SPACER RMKS:

REMARKS:
CKT 1:
SAG CHART 336.4 KCMIL ACSR PER T13804372, 324'RS, 4280#MT

CKT 2:

ELEVATIONS

GROUNDLINE:
SETTING:
CENTERLINE:

FRAMING

POLE STAY

SWAMP FIXT

PLAN & PROFILE

DWG:
SH: FIG: REV:

RWA

DWG:
SH: FIG: REV:

CWA

DWG: T13804345
SH: FIG: REV:

LIGHTNING ARRESTOR

GROUND WIRE

LINE 006AF CKT 1
 SIZE: 80 KCMIL ACSR SH FIG REV SH FIG REV
 DWG NO: TL0019081 1 3
 SAG DWG: T13804371
 DAMPERS DWG:

REMARKS:
CKT 1:
SAG CHART 80 KCMIL ACSR PER T13804371, 324'RS, 2050#MT.

CKT 2:

GENERAL REMARKS

STRUCTURE LOCATION

PROP OWNER:
PARCEL NO:
REMARKS:

TYPE OF RIGHT-OF-WAY:

COUNTY: ISABELLA
TOWNSHIP: CHIPPEWA
TOWN/RANGE: T14N,R03W
SECTION: 30

REVISION

LETTER: MWO NO:
GWO: 1242 DATE: 6/9/2000
RS NO: 45116 DESIGNER: KDK
NOTES: NEW CONSTR LIST LINE 6AF - ADDED POLES FOR LINE

PREPARED BY: KDKING
DATE: 6/9/2000
APPROVED BY: CRCOLEMAN
DATE: 6/9/2000
DEPT. HEAD: BD BUGBEE
DIVISION HEAD: RG COTTRELL

LINE NO/LTR: 006AF
STR ORDER: 234
STRUCT #: 212

LINE NAME : ALMA-SUMMERTON

UNIQUE STRUCT #: W0106624 ORDER: 235

LINE NO/LTR:	006AF
STRUCT #:	213
OP VOLTAGE:	138
STN/EQ :	676.50
BACK SPAN:	317.00
DEFLECTION:	
TYPE:	WOOD POLE
POLE HT:	85
POLE CLASS:	2
CONST TYPE:	HP

STRUCTURE

DWG: TL0019251 SH: FIG: REV:

REMARKS: EXCEPT INSTALL INSULATORS ON EAST SIDE OF POLES 204-217
USE CRUSHED ROCK BACKFILL.

GUYING:

CONDUCTORS

LINE	006AF	CKT	1	LINE	CKT	SH	FIG	REV
SIZE 1 & 2:	336.4	KCMIL	ACSR					
DES VOLTAGE:						SH	FIG	REV
DWG:	TL0019035					3	17	
SAG DWG:	T13804372							
JMPR STR DWG:								
DAMPERS DWG:								
SPACER DWG #:								
SPACER RMKS:								

REMARKS:
CKT 1:
SAG CHART 336.4 KCMIL ASCR PER T13804372, 324'RS, 4280#MT

CKT 2:

ELEVATIONS

GROUNDLINE:
SETTING:
CENTERLINE:

FRAMING

POLE STAY

SWAMP FIXT

PLAN & PROFILE

DWG:
SH: FIG: REV:

RWA

DWG:
SH: FIG: REV:

CWA

DWG: T13804345
SH: FIG: REV:

LIGHTNING ARRESTOR

GROUND WIRE

LINE	006AF	CKT	1	LINE	CKT	SH	FIG	REV
SIZE:	80	KCMIL	ACSR					
DWG NO:	TL0019081					SH	FIG	REV
SAG DWG:	T13804371					1	3	
DAMPERS DWG:								

REMARKS:
CKT 1:
SAG CHART 80 KCMIL ASCR PER T13804371, 324'RS, 2050#MT.

CKT 2:

GENERAL REMARKS

STRUCTURE LOCATION

PROP OWNER:
PARCEL NO:
REMARKS:

TYPE OF RIGHT-OF-WAY:

COUNTY: ISABELLA
TOWNSHIP: CHIPPEWA
TOWN/RANGE: T14N,R03W
SECTION: 30

REVISION

LETTER: MWO NO:
GWO: 1242 DATE: 6/9/2000
RS NO: 45116 DESIGNER: KDK
NOTES: NEW CONSTR LIST LINE 6AF - ADDED POLES FOR LINE

PREPARED BY: KDKING
DATE: 6/9/2000
APPROVED BY: CRCOLEMAN
DATE: 6/9/2000
DEPT. HEAD: BD BUGBEE
DIVISION HEAD: RG COTTRELL

LINE NO/LTR: 006AF
STR ORDER: 235
STRUCT #: 213

LINE NAME : ALMA-SUMMERTON

UNIQUE STRUCT #: W0106625 ORDER : 236

LINE NO/LTR:	006AF
STRUCT #:	214
OP VOLTAGE:	138
STN/EQ :	679.67
BACK SPAN:	317.00
DEFLECTION:	
TYPE:	WOOD POLE
POLE HT:	85
POLE CLASS:	2
CONST TYPE:	HP

STRUCTURE

DWG: TL0019251 SH: FIG: REV:

REMARKS: EXCEPT INSTALL INSULATORS ON EAST SIDE OF POLES 204-217
USE CRUSHED ROCK BACKFILL.

GUYING:

CONDUCTORS

LINE	006AF	CKT	1	LINE	CKT	SH	FIG	REV	SH	FIG	REV
SIZE 1 & 2:	336.4 KCMIL ACSR										
DES VOLTAGE:											
DWG:	TL0019035					3	17				
SAG DWG:	T13804372										
JMPR STR DWG:											
DAMPERS DWG:											
SPACER DWG #:											
SPACER RMKS:											

REMARKS:

CKT 1:
SAG CHART 336.4 KCMIL ACSR PER T13804372, 324'RS, 4280#MT

CKT 2:

ELEVATIONS

GROUNDLINE:
SETTING:
CENTERLINE:

FRAMING

POLE STAY

SWAMP FIXT

PLAN & PROFILE

DWG:
SH: FIG: REV:

RWA

DWG:
SH: FIG: REV:

GROUND WIRE

LINE	006AF	CKT	1	LINE	CKT	SH	FIG	REV	SH	FIG	REV
SIZE:	80 KCMIL ACSR										
DWG NO:	TL0019081					1	3				
SAG DWG:	T13804371										
DAMPERS DWG:											

REMARKS:

CKT 1:
SAG CHART 80 KCMIL ACSR PER T13804371, 324'RS, 2050#MT.

CKT 2:

CWA

DWG: T13804345
SH: FIG: REV:

LIGHTNING ARRESTOR

GENERAL REMARKS

STRUCTURE LOCATION

PROP OWNER:
PARCEL NO:
REMARKS:

TYPE OF RIGHT-OF-WAY:

COUNTY: ISABELLA
TOWNSHIP: CHIPPEWA
TOWN/RANGE: T14N,R03W
SECTION: 30

REVISION

LETTER:	MWO NO:	PREPARED BY: KDKING
GWO: 1242	DATE: 6/9/2000	DATE: 6/9/2000
RS NO: 45116	DESIGNER: KDK	APPROVED BY: CRCOLEMAN
NOTES: NEW CONSTR LIST LINE 6AF - ADDED POLES FOR LINE		DATE: 6/9/2000
		DEPT. HEAD: BD BUGBEE
		DIVISION HEAD: RG COTTRELL

LINE NO/LTR:	006AF
STR ORDER:	236
STRUCT #:	214

LINE NAME : ALMA-SUMMERTON

UNIQUE STRUCT #: W0106626 ORDER : 237

LINE NO/LTR:	006AF
STRUCT #:	215
OP VOLTAGE:	138
STN/EQ :	682.84
BACK SPAN:	317.00
DEFLECTION:	
TYPE:	WOOD POLE
POLE HT:	85
POLE CLASS:	2
CONST TYPE:	HP

STRUCTURE

DWG: TL0019251 SH: FIG: REV:

REMARKS: EXCEPT INSTALL INSULATORS ON EAST SIDE OF POLES 204-217
USE CRUSHED ROCK BACKFILL.

GUYING:

CONDUCTORS

LINE 006AF CKT 1
 SIZE 1 & 2: 336.4 KCMIL ACSR
 DES VOLTAGE: SH FIG REV SH FIG REV
 DWG: TL0019035 3 17
 SAG DWG: T13804372
 JMPR STR DWG:
 DAMPERS DWG:
 SPACER DWG #:
 SPACER RMKS:

REMARKS:
CKT 1:
SAG CHART 336.4 KCMIL ACSR PER T13804372, 324'RS, 4280#MT

CKT 2:

ELEVATIONS

GROUNDLINE:
SETTING:
CENTERLINE:

FRAMING

POLE STAY

SWAMP FIXT

PLAN & PROFILE

DWG:
SH: FIG: REV:

RWA

DWG:
SH: FIG: REV:

CWA

DWG: T13804345
SH: FIG: REV:

LIGHTNING ARRESTOR

GROUND WIRE

LINE 006AF CKT 1
 SIZE: 80 KCMIL ACSR SH FIG REV SH FIG REV
 DWG NO: TL0019081 1 3
 SAG DWG: T13804371
 DAMPERS DWG:

REMARKS:
CKT 1:
SAG CHART 80 KCMIL ACSR PER T13804371, 324'RS, 2050#MT.

CKT 2:

GENERAL REMARKS

STRUCTURE LOCATION

PROP OWNER:
PARCEL NO:
REMARKS:

TYPE OF RIGHT-OF-WAY:

COUNTY: ISABELLA
TOWNSHIP: CHIPPEWA
TOWN/RANGE: T14N,R03W
SECTION: 30

REVISION

LETTER: MWO NO:
GWO: 1242 DATE: 6/9/2000
RS NO: 45116 DESIGNER: KDK
NOTES: NEW CONSTR LIST LINE 6AF - ADDED POLES FOR LINE

PREPARED BY: KDKING
DATE: 6/9/2000
APPROVED BY: CRCOLEMAN
DATE: 6/9/2000
DEPT. HEAD: BD BUGBEE
DIVISION HEAD: RG COTTRELL

LINE NO/LTR: 006AF
STR ORDER: 237
STRUCT #: 215

LINE NAME: ALMA-SUMMERTON

UNIQUE STRUCT #: W0106627 ORDER: 238

LINE NO/LTR:	006AF
STRUCT #:	216
OP VOLTAGE:	138
STN/EQ :	686.00
BACK SPAN:	316.00
DEFLECTION:	
TYPE:	WOOD POLE
POLE HT:	85
POLE CLASS:	2
CONST TYPE:	HP

STRUCTURE

DWG: TL0019251 SH: FIG: REV:

REMARKS: EXCEPT INSTALL INSULATORS ON EAST SIDE OF POLES 204-217
USE CRUSHED ROCK BACKFILL.

GUYING:

CONDUCTORS

LINE 006AF CKT 1
 SIZE 1 & 2: 336.4 KCMIL ACSR
 DES VOLTAGE: SH FIG REV SH FIG REV
 DWG: TL0019035 3 17
 SAG DWG: T13804372
 JMPR STR DWG:
 DAMPERS DWG:
 SPACER DWG #:
 SPACER RMKS:

REMARKS:

CKT 1:
SAG CHART 336.4 KCMIL ACSR PER T13804372, 324'RS, 4280#MT

CKT 2:

ELEVATIONS

GROUNDLINE:
SETTING:
CENTERLINE:

FRAMING

POLE STAY

SWAMP FIXT

PLAN & PROFILE

DWG:
SH: FIG: REV:

RWA

DWG:
SH: FIG: REV:

CWA

DWG: T13804345
SH: FIG: REV:

LIGHTNING ARRESTOR

GROUND WIRE

LINE 006AF CKT 1
 SIZE: 80 KCMIL ACSR SH FIG REV SH FIG REV
 DWG NO: TL0019081 1 3
 SAG DWG: T13804371
 DAMPERS DWG:

REMARKS:

CKT 1:
SAG CHART 80 KCMIL ACSR PER T13804371, 324'RS, 2050#MT.

CKT 2:

GENERAL REMARKS

STRUCTURE LOCATION

PROP OWNER:
PARCEL NO:
REMARKS:

TYPE OF RIGHT-OF-WAY:

COUNTY: ISABELLA
TOWNSHIP: CHIPPEWA
TOWN/RANGE: T14N,R03W
SECTION: 30

REVISION

LETTER: MWO NO: PREPARED BY: KDKING
GWO: 1242 DATE: 6/9/2000
RS NO: 45116 DESIGNER: KDK
NOTES: NEW CONSTR LIST LINE 6AF - ADDED POLES FOR LINE

APPROVED BY: CRCOLEMAN
DATE: 6/9/2000
DEPT. HEAD: BD BUGBEE
DIVISION HEAD: RG COTTRELL

LINE NO/LTR: 006AF
STR ORDER: 238
STRUCT #: 216

LINE NAME : ALMA-SUMMERTON

UNIQUE STRUCT #: W0106628 ORDER : 239

LINE NO/LTR:	006AF
STRUCT #:	217
OP VOLTAGE:	138
STN/EQ :	689.20
BACK SPAN:	320.00
DEFLECTION:	
TYPE:	WOOD POLE
POLE HT:	85
POLE CLASS:	2
CONST TYPE:	HP

STRUCTURE

DWG: TL0019251 SH: FIG: REV:

REMARKS: EXCEPT INSTALL INSULATORS ON EAST SIDE OF POLES 204-217
USE CRUSHED ROCK BACKFILL.

GUYING:

CONDUCTORS

LINE 006AF CKT 1
 SIZE 1 & 2: 336.4 KCMIL ACSR
 DES VOLTAGE: SH FIG REV SH FIG REV
 DWG: TL0019035 3 17
 SAG DWG: T13804372
 JMPR STR DWG:
 DAMPERS DWG:
 SPACER DWG #:
 SPACER RMKS:

REMARKS:

CKT 1:
SAG CHART 336.4 KCMIL ACSR PER T13804372, 324'RS, 4280#MT

CKT 2:

ELEVATIONS

GROUNDLINE:
SETTING:
CENTERLINE:

FRAMING

POLE STAY

SWAMP FIXT

PLAN & PROFILE

DWG:
SH: FIG: REV:

RWA

DWG:
SH: FIG: REV:

CWA

DWG: T13804345
SH: FIG: REV:

LIGHTNING ARRESTOR

GROUND WIRE

LINE 006AF CKT 1
 SIZE: 80 KCMIL ACSR SH FIG REV SH FIG REV
 DWG NO: TL0019081 1 3
 SAG DWG: T13804371
 DAMPERS DWG:

REMARKS:

CKT 1:
SAG CHART 80 KCMIL ACSR PER T13804371, 324'RS, 2050#MT.

CKT 2:

GENERAL REMARKS

STRUCTURE LOCATION

PROP OWNER:
PARCEL NO:
REMARKS:

TYPE OF RIGHT-OF-WAY:

COUNTY: ISABELLA
TOWNSHIP: CHIPPEWA
TOWN/RANGE: T14N,R03W
SECTION: 30

REVISION

LETTER: MWO NO:
GWO: 1242 DATE: 6/9/2000
RS NO: 45116 DESIGNER: KDK
NOTES: NEW CONSTR LIST LINE 6AF - ADDED POLES FOR LINE

PREPARED BY: KDKING
DATE: 6/9/2000
APPROVED BY: CRCOLEMAN
DATE: 6/9/2000
DEPT. HEAD: BD BUGBEE
DIVISION HEAD: RG COTTRELL

LINE NO/LTR: 006AF
STR ORDER: 239
STRUCT #: 217

LINE NAME : ALMA-SUMMERTON

UNIQUE STRUCT #: W0106629 ORDER : 240

LINE NO/LTR:	006AF
STRUCT#:	218
OP VOLTAGE:	138
STN/EQ :	692.38
BACK SPAN:	318.00
DEFLECTION:	90-00'-00" RT
TYPE:	WOOD POLE
POLE HT:	90
POLE CLASS:	H1
CONST TYPE:	DE

STRUCTURE

DWG: TL0019202 SH: FIG: REV:

REMARKS: USE CRUSHED ROCK BACKFILL. NO RAKE, BUTT 5' EAST OF CL. SEE DWG T13804379 FOR CONDUCTOR PLAN.

GUYING: 2-7/16" EHS DOWN 50' & 45' N TO SS-PISA, 8 SP & 2 GUY GUARDS PER ANC.

CONDUCTORS

LINE	006AF	CKT	1	LINE	CKT	SH	FIG	REV
SIZE 1 & 2: 336.4 KCMIL ACSR								
DES VOLTAGE:								
DWG: TL0019035 SH 2 FIG 10								
SAG DWG: T13804372								
JMPR STR DWG:								
DAMPERS DWG:								
SPACER DWG #:								
SPACER RMKS:								

REMARKS:

CKT 1:
SAG CHART 336.4 KCMIL ACSR PER T13804372, 324'RS, 4280#MT
SEE DWG T13804379 FOR CONDUCTOR PLAN. CHANGE TENSION : SLACK SPAN POLE 218 - 219.

CKT 2:

ELEVATIONS

GROUNDLINE:
SETTING:
CENTERLINE:

FRAMING

POLE STAY

SWAMP FIXT

PLAN & PROFILE

DWG:
SH: FIG: REV:

RWA

DWG:
SH: FIG: REV:

CWA

DWG: T13804345
SH: FIG: REV:

LIGHTNING ARRESTOR

GROUND WIRE

LINE	006AF	CKT	1	LINE	CKT	SH	FIG	REV
SIZE: 80 KCMIL ACSR								
DWG NO: TL0019081 SH 1 FIG 6								
SAG DWG: T13804371								
DAMPERS DWG:								

REMARKS:

CKT 1:
SAG CHART 80 KCMIL ACSR PER T13804371, 324'RS, 2050#MT.
CHANGE TENSION : SLACK SPAN POLE 218 - 219.

CKT 2:

GENERAL REMARKS

STRUCTURE LOCATION

PROP OWNER:
PARCEL NO:
REMARKS:

TYPE OF RIGHT-OF-WAY:

COUNTY: ISABELLA
TOWNSHIP: CHIPPEWA
TOWN/RANGE: T14N,R03W
SECTION: 30

REVISION

LETTER: MWO NO:
GWO: 1242 DATE: 6/9/2000
RS NO: 45116 DESIGNER: KDK
NOTES: NEW CONSTR LIST LINE 6AF - ADDED POLES FOR LINE

PREPARED BY: KDKING
DATE: 6/9/2000
APPROVED BY: CRCOLEMAN
DATE: 6/9/2000
DEPT. HEAD: BD BUGBEE
DIVISION HEAD: RG COTTRELL

LINE NO/LTR: 006AF
STR ORDER: 240
STRUCT #: 218

Subject: RE: Notification: CE Proposed Project - Summerton-Alma
From: "Richard N. Collins" <rnccollins@cai-engr.com>
Date: Tue, 16 May 2006 15:39:21 -0400
To: "Jim Smith" <jsmith@metcllc.com>
CC: "Richard D. Pulley" <rdpulley@cai-engr.com>, "fernando Guevara" <Fguevara@nsidatatechs.com>

CU-208

Jim,

This is CU-208. I thought this was rejected and/or cancelled before. Has something changed that we should review this again? Does METC planning want this to happen? I did some estimating stuff on this for Ruth a little while ago.

Sincerely,

Rich Collins

From: Jim Smith [mailto:jsmith@metcllc.com]
Sent: Tuesday, May 09, 2006 1:40 PM
To: racollins@cmsenergy.com; Richard N. Collins
Subject: RE: Notification: CE Proposed Project - Summerton-Alma

Sorry Rich A Collins, this should have gone to Rich N. Collins. Damn, can one of you change there names. Haha, Sorry about that

James W. Smith
Manager, Program Maintenance
Michigan Electric Transmission Company, LLC
3001 Orchard Vista Drive, S.E.
Suite 300
Grand Rapids, Michigan 49456

E-mail: jsmith@metcllc.com
Phone (616) 482.1366
Fax: (616) 482.1485

** This e-mail and any of its attachments may contain Michigan Electric Transmission Company, LLC proprietary information, which is privileged, confidential, or subject to copyright belonging to Michigan Electric Transmission Company, LLC. This e-mail is intended solely for the use of the individual or entity to which it is addressed. If you are not the intended recipient of this e-mail, you are hereby notified that any dissemination, distribution, copying, or action taken in relation to the contents of and attachments to this e-mail is strictly prohibited and may be unlawful. If you have received this e-mail in error, please notify the sender immediately and permanently delete the original and any copy of this e-mail and any printout. Thank You. **

From: Jim Smith
Sent: Tuesday, May 09, 2006 1:37 PM
To: Richard A. collins (racollins@cmsenergy.com); Rich D Pulley (rdpulley@cai-engr.com); Fernando Guevara; Claro Guico
Cc: Phil Mann (pmann@nsi-consulting.com); Ruth M. Kloecker; Steve Quade
Subject: FW: Notification: CE Proposed Project - Summerton-Alma

All,

Heads up on new CU, if you have any q questions give me a call. This is the same CU that we went around and around with CE on the previous request that was cancelled.

James W. Smith
Manager, Program Maintenance
Michigan Electric Transmission Company, LLC
3001 Orchard Vista Drive, S.E.
Suite 300
Grand Rapids, Michigan 49456

E-mail: jsmith@metc.com
Phone (616) 482.1366
Fax: (616) 482.1485

** This e-mail and any of its attachments may contain Michigan Electric Transmission Company, LLC proprietary information, which is privileged, confidential, or subject to copyright belonging to Michigan Electric Transmission Company, LLC. This e-mail is intended solely for the use of the individual or entity to which it is addressed. If you are not the intended recipient of this e-mail, you are hereby notified that any dissemination, distribution, copying, or action taken in relation to the contents of and attachments to this e-mail is strictly prohibited and may be unlawful. If you have received this e-mail in error, please notify the sender immediately and permanently delete the original and any copy of this e-mail and any printout. Thank You. **

From: Kevin C Lott [<mailto:kclott@cmsenergy.com>]

Sent: Friday, May 05, 2006 9:02 AM

To: pmann@nsi-consulting.com

Cc: Jim Smith; Paul F Johnson; Bruce D Bugbee; Gary A Bultsma; Richard A Collins; James R Anderson; Mary Anne Marr; Brian G Ott; Kurt A Rudolph; Timothy J Sparks; Steven L Ray; Dwayne C Parker; Lisa M DeLacy; Marilyn J Leighty

Subject: Notification: CE Proposed Project - Summerton-Alma

This is notification by Consumers Energy to METC, LLC of CE's proposed usage of existing future double circuit poles, on which METC, LLC currently has one 138 kV circuit. Per CE-METC Planning Practice 8, CE is notifying METC, LLC of its proposed usage of the subject pole structures for the installation of a 46 kV circuit from pole #191 to pole #218 of the Summerton-Alma 138 kV line (approximately 1.6 miles).

This message is being sent in conjunction with the formal notification via registered mail. Please review CE's proposed usage and, if METC, LLC finds it to be a Compatible Use, sign one of the paper copies of the letter being sent to you and return it to me. If METC, LLC finds CE's proposed usage to not be a Compatible Use, then please provide me with your written explanation as to why METC, LLC arrived at that determination along with any suggested alternatives that METC, LLC may have in mind that would lead to resolution.

Per Section 7.1 of EA, METC, LLC has 30 days from receipt of the registered mail notification to provide CE with its written response concerning this proposed usage. Depending on the day the notification is received, the due date for your response is approximately June 5, 2006.

If you have any questions concerning this proposed usage by CE, please contact me at 517-788-1471.

K.C. Lott
kclott@cmsenergy.com

Subject: CU-208

From: "Richard D. Pulley" <rdpulley@cai-engr.com>

Date: Thu, 1 Jun 2006 11:42:25 -0400

To: "Jim Smith" <jsmith@metcllc.com>, "Ruth M. Kloecker" <rkloecker@metcllc.com>

CC: "Fernando Guevara" <fguevara@nsi-consulting.com>, "Richard N. Collins" <rencollins@cai-engr.com>

Jim/Ruth,

This line was designed for a double circuit of witch METC only has one currently installed. Therefore, we have nothing to check at this time and it becomes a planning issue. If you should have any questions do not hesitate to call.

Sincerely,

Rich Pulley

Civil/Structural Engineer

Commonwealth Associates, Inc

Phone Number: (517) 788-3008

E-Mail: rdpulley@cai-engr.com

METC

Michigan Electric Transmission Company, LLC
A TRANS-ELECT ENTERPRISE

COMPATIBLE USE REQUEST

MONTH/YEAR MAY 2006 DATE OF REQUEST 5/8/2006
METC FILE # CU-208 DUE DATE 6/6/2006
CE REFERENCE # _____ DUE DATE NSI 6/5/2006
CAI TASK # C208 DATE APPROVED 6/1/06

COMPATIBLE USER Consumers Energy TYPE OF USE Proposed Use of Alma-Summerton Future Double Circuit

LOCATION Isabella/Chippewa TOWNSHIP Chippewa COUNTY Isabella
SECTION 31 QUARTER SECTION _____ TOWN 14N RANGE 3W

TRANSMISSION LINE NAME Alma-Summerton LINE NUMBER 6AF VOLTAGE 138kV
STRUCTURE NUMBER 191 through 218 STRUCTURE TYPE Wood Pole STRUCTURE HEIGHT _____

OPERATING MVA _____ SHORT TERM EMERGENCY RATING _____
LIMITING FACTOR _____ LONG TERM EMERGENCY RATING _____

HEIGHT OF METC CONDUCTOR AT CROSSING _____
HEIGHT OF UTILITY AT CROSSING _____
CONDUCTOR TEMPERATURE FOR CLEARANCE CHECK _____
CLEARANCE MEETS NESC +2' BUFFER AT NORMAL OPERATING TEMPERATURE YES NO
CLEARANCE MEETS NESC AT _____ NORMAL OPERATING MVA YES NO
SHORT TERM EMERGENCY RATING YES NO
LONG TERM EMERGENCY RATING YES NO
6 PSF BLOW OUT CLEARANCE _____ NESC REQUIRED BLOW OUT CLEARANCE _____

IS STRUCTURE ADEQUATE FOR UTILITY ATTACHMENT YES NO

MEETS METC STANDARS YES NO ATTACHED DOCUMENTATION YES NO
MEETS NECS STANDARS YES NO PLAN & PROFILE REVISED YES NO
APPROVED PROJECT FOR THIS LINE OR CORRIDOR YES NO

COMMENTS:

ASSET MANAGER _____ PROPERTY MANAGEMENT FG ENGINEERING DET RDP PLANNING DEPT _____