

UNDERGROUND EASEMENT (RIGHT OF WAY) NO. R-9302062-10R

On May 19, 1993, for the consideration of system betterment, Grantor grants to Grantee a permanent underground easement ("Right of Way") in, on and across a part of Grantor's Land called the "Right of Way Area".

Grantor is:

Adam J. Maida, the Roman Catholic Archbishop of the Archdiocese of Detroit, 1234 Washington Blvd. Detroit, Michigan 48226

"Grantee" is:

The Detroit Edison Company, a Michigan corporation, 2000 Second Avenue, Detroit, Michigan 48226
GTE North, Incorporated, a Wisconsin corporation, 455 E. Ellis, Muskegon, Michigan 49443
Concord Tele-Communications, a Michigan corporation, 21 S. Washington, Oxford, Michigan 48051

"Grantor's Land" is in Brandon Township, Oakland County, Michigan, described as:

Part of Southwest fr^c 1/4 of Section 18, T5N, R9E, beginning at point distance South 89°06'00" E 1300.71 feet and North 07°57'56" W 676.65 feet from Southwest Section Corner; thence along curve concave Easterly, radius 5669.65 feet, chord bears North 02°13'43" W 457.55 feet, distance of 457.67 feet; thence North 00°05'02" E 82.28 feet; thence North 88°18'32" E 506.20 feet; thence South 00°05'02" E 539.97 feet; thence South 88°18'32" W 487.71 feet to beginning. 6.21 acres.

Sidwell No: 03-18-376-004

The "Right of Way Area" is a part of Grantor's Land and is described as:

As shown on the attached D.E. Company Drawing No: R-9302062-10R. The Right of Way is 10 feet in width.

- 1. Purpose:** The purpose of this Right of Way is to construct, reconstruct, modify, add to, operate and maintain underground utility line facilities consisting of poles, guys, anchors, wires, manholes, conduits, pipes, cables, transformers and accessories.
- 2. Access:** Grantee has the right of access to and from the Right of Way Area.
- 3. Buildings or other Permanent Structures:** No buildings or other permanent structures shall be placed in the Right of Way Area without Grantee's prior written consent.
- 4. Excavation:** As required by Public Act 53 of 1974, MISS DIG must be called on 1-800-482-7171 before anyone excavates in the Right of Way Area.
- 5. Trees, Bushes, Branches, Roots, Structures and Fences:** Grantee may trim, cut down, remove or otherwise control any trees, bushes, branches and roots in the Right of Way Area (or that could grow into the Right of Way Area) and remove structures and fences in the Right of Way Area that Grantee believes could interfere with the safe and reliable construction, operation and maintenance of Grantee's facilities. No trees, plant life, structures and fences shall be planted, grown or installed within 8 feet of the front door and within 2 feet of the other sides of transformers and switching cabinet enclosures. Grantee shall not be responsible to Grantor for damages to or removal of trees, plant life, structures and fences placed in front of transformer doors.
- 6. Restoration:** If Grantee's employees, contractors, vehicles or equipment damage Grantor's Land while entering Grantor's Land for the purposes stated in this Right of Way, then Grantee shall restore Grantor's Land as nearly as can be to its original condition.
- 7 Successors:** This Right of Way runs with the land and binds and benefits Grantor's and Grantee's successors, lessees, licensees and assigns.

Witnesses:(type or print name below signature)

Grantor:(type or print name below signature)

Gerald T. Chuhran
Gerald T. Chuhran

X Adam J. Maida
Adam J. Maida

Rosalie L. Higgins
Rosalie L. Higgins

The Roman Catholic Archbishop of the Archdiocese of Det.

0001 JUL.21.93 12:16PM 9.00
3475 RMT FEE 2.00
2.00RMT

Acknowledged before me in Wayne County, Michigan, on May 19, 1993
by Adam J. Maida, the Roman Catholic Archbishop of the Archdiocese of Detroit.

My commission expires: 10/9/94
Notary's Stamp Gerald T. Chuhran
(Notary's name, county and date commission expires)

Notary's Signature Gerald T. Chuhran
Macomb acting in Wayne County

Prepared by and Return to: John C. Greenlee, 1970 Orchard Lake Road, Sylvan Lake, Michigan 48320/kjk.

Return-over

OK - TS

RECORDED RIGHT OF WAY NO. 449146

11/15/71

RECEIVED
DETROIT EDISON CO.
NOV 15 1971



[Handwritten signature]

DETROIT EDISON CO.
1970 ORCHARD LAKE RD.
SYLVAN LAKE, MI 48320

**RETURN TO
TERRY L. BENEDICT
THE DETROIT EDISON COMPANY
1970 ORCHARD LAKE RD.
SYLVAN LAKE, MI 48320**

LIBER 13786 PP 835

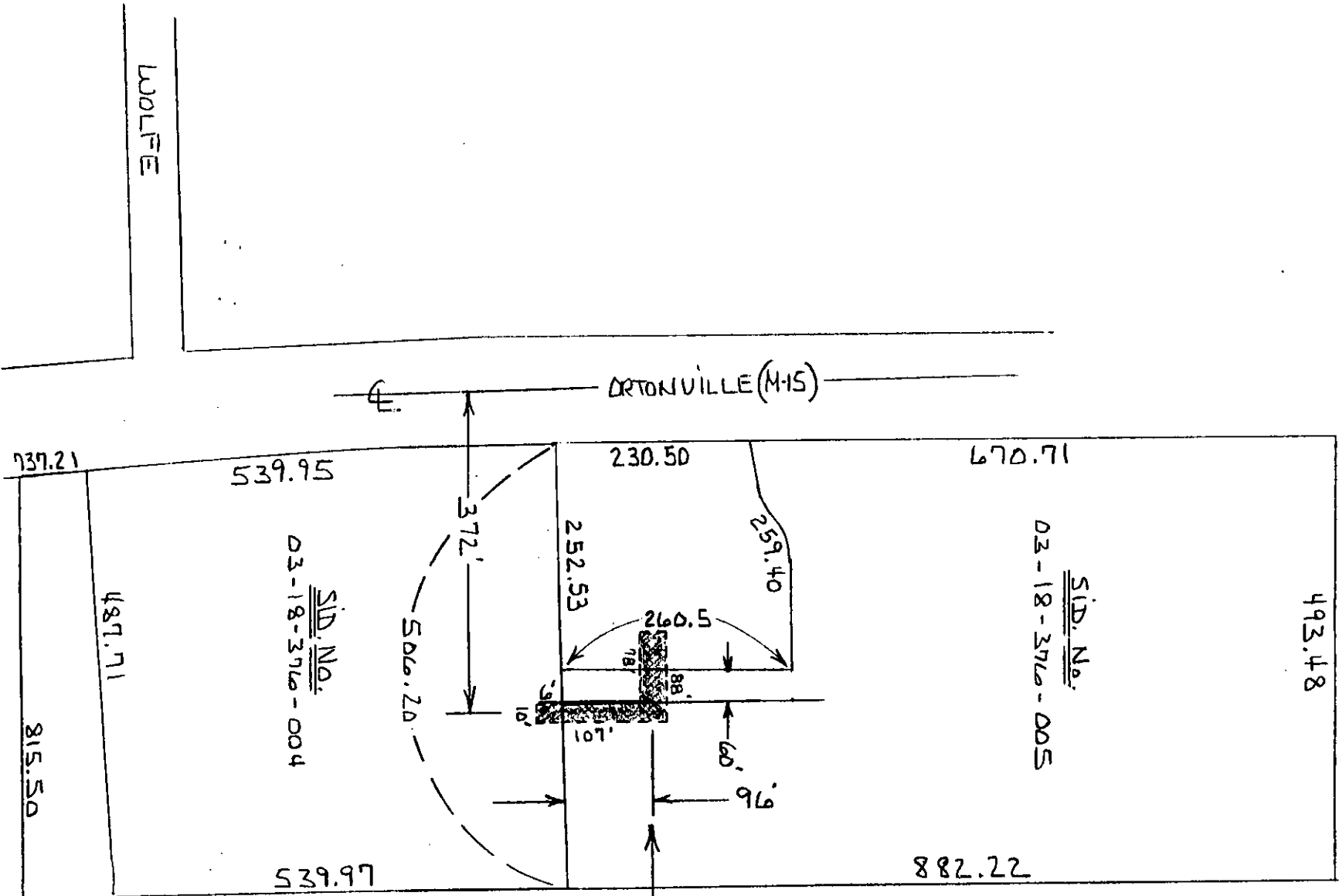

CENTERLINE OF 10 FOOT WIDE EASEMENT
 Note: The easement centerline may vary if field construction problems arise. Therefore, for the as-installed easement centerline call 1-800-482-7171 (Miss Dig).

RECORDED RIGHT OF WAY NO. 44916

S.E. COR. OF
 W. 1/2 SEC. 18



R-9302062-16R

PLNR = K.W.

RETURN TO
TERRY L. BENEDICT
THE DETROIT EDISON COMPANY
1970 ORCHARD LAKE RD.
SYLVAN LAKE, MI 48320