

STATE OF MICHIGAN

Office of the Michigan Public Utilities Commission, } ss.

I, Clarke W. Brown, Secretary of the Michigan Public Utilities Commission

Do Hereby Certify, That I have compared the annexed copy of Permit ED2-8- 404

with the original

recorded in File ED2-8- 404

and that it is a true and correct transcript therefrom, and of the whole of such original.

In Testimony Whereof, I have hereunto set my hand and affixed the seal of the Commission, at Lansing, this 12th day of January in the year of our Lord one thousand nine hundred thirty-seven.

Clarke W. Brown

Secretary Michigan Public Utilities Commission

4105

4105

RECORDED RIGHT OF WAY NO. 34636 p92

STATE OF MICHIGAN  
BEFORE MICHIGAN PUBLIC UTILITIES COMMISSION

Standard Railroad Wire-Crossing Permit No. **EDS-8-404**

In Re Application of **Detroit Edison Company (Detroit)**

Pursuant to Act No. 171 of the Session Laws of 1893, as amended, application having been made to Michigan Public Utilities Commission by said

**Detroit Edison Company**  
for permission to string wires across the tracks of the  
**Grand Trunk Western Railroad**  
and said **Detroit Edison Company**

having conformed to the Commission's rules governing the filing of notices and issuing of permits for the construction of electrical lines and said rail road company having waived the right of notice and hearing provided for in said act

THEREFORE, It is ordered that said

**Detroit Edison Company**

be permitted to string the following described wires across the tracks of said railroad at the following described place:

**In Lyon Township,  
Oakland County,  
Michigan;--**

**In Martindale Road, 1 mile northeast of  
South Lyon, in southeast quarter of  
Section 17, T-14N, R-7-E, with:  
3 - #1/0 copper wires, 24000 volts, 3-ph;  
3 - # 4 " " 4800 " "  
2 - # 8 " telephone wires**

as indicated on the attached plans, when, as and if approved.

At the point of crossing said wires shall be constructed in accordance with this Commission's rules and regulations.

Given under our hands and the Official Seal of this Commission at the City of Lansing, State of Michigan, this 18th day of January A. D. 1937

MICHIGAN PUBLIC UTILITIES COMMISSION  
By

.....**William M. Smith**.....  
Chairman,

.....**Emerson R. Boyles**.....  
Commissioner,

.....**Ivan E. Hull**.....  
Commissioner,

Countersigned

.....**Clarke W. Brown**.....  
Secretary

.....**Paul W. Voorhies**.....  
Commissioner,

.....**Harold J. Naples**.....  
Commissioner.

RECORDED RIGHT OF WAY NO.

34636  
p 92

GRAND TRUNK WESTERN RAILROAD COMPANY  
OFFICE OF SUPERINTENDENT

W. J. Hogan,  
Superintendent.

(e) Battle Creek, Jan., 11, 1937

4730-434

JAN 12 1937  
330  
31  
30

Michigan Public Utilities Commission,  
Lansing, Michigan.

Gentlemen:--

We are in receipt of request from the Detroit Edison Company, Detroit, Michigan, for waiver of hearing covering the rebuilding of crossing over our tracks in Martindale Road, One Mile Northeast of South Lyon, Southeast Quarter of Section 17, Lyon Township, Oakland County, Michigan, changing 24,000 volt wires from triangular to flat construction and reguying crossing poles.

The Detroit Edison Company advise that construction of this crossing will be in accordance with specifications of the Commission, in view of which we have no objections, and you may consider this letter as our waiver of hearing as requested.

Yours very truly,

*W. J. Hogan*  
Superintendent.

CC: Detroit Edison Company,  
Detroit, Michigan.  
Attention: Mr. G. B. Hayes.

R+ 164 A  
2-8-404

RECORDED RIGHT OF WAY 34-636 P 9 2

RX 1644

**THE DETROIT EDISON CO.**

PLAN SUBMITTED TO MICHIGAN PUBLIC UTILITIES COMMISSION  
FOR  
OVERHEAD LINE CROSSING

OVER GRAND TRUNK R.R.  
IN MARTINDALE ROAD  
CITY OF 1/2 MILE NE OF SOUTH LYON SE 1/4 SECTION 17  
LYON TOWNSHIP T. IN R. 7E OAKLAND COUNTY

CIRCUITS				CONDUCTORS			
NUMBER	VOLTAGE	CYCLES	PHASE	USE	WIRES	SIZE	KIND
ONE	24000	60	3	TRANS	3	#0	H BARE STR COPPER
ONE	4800	60	3	DIST	3	#4	MH TRWP SOLID COPPER
ONE	(RINGING)			TELEPHONE	2	#8	MH BARE SOLID COPPER

POLES							
LOCATION	LENGTH	MATERIAL	CIRCUMFERENCE		DEPTH OF SETTING	KIND OF SETTING	
			AT TOP	AT GROUND			
A	40'	SOUTHERN PINE	23"	36"	6'	CLAY SOIL	
B	50'	WESTERN CEDAR	23"	45"	7'	"	
C	50'	"	25"	47"	7'	"	
D	40'	"	21"	39"	6'	"	

**NOTE**  
MATERIALS SHALL BE AS NOTED IN THE DETROIT EDISON COMPANY'S STANDARD SPECIFICATIONS FOR OVERHEAD LINE CONSTRUCTION AT RAILROAD CROSSINGS ISSUED DECEMBER 23, 1935.

**PURPOSE OF LINE**  
CHANGING 24000 VOLT WIRES FROM TRIANGULAR TO FLAT CONSTRUCTION AND REGUING CROSSING POLES EXISTING PERMIT U-2139

DRAWN BY ABC DATE 12-30-36 CHECKED BY VD DATE 12-30-36

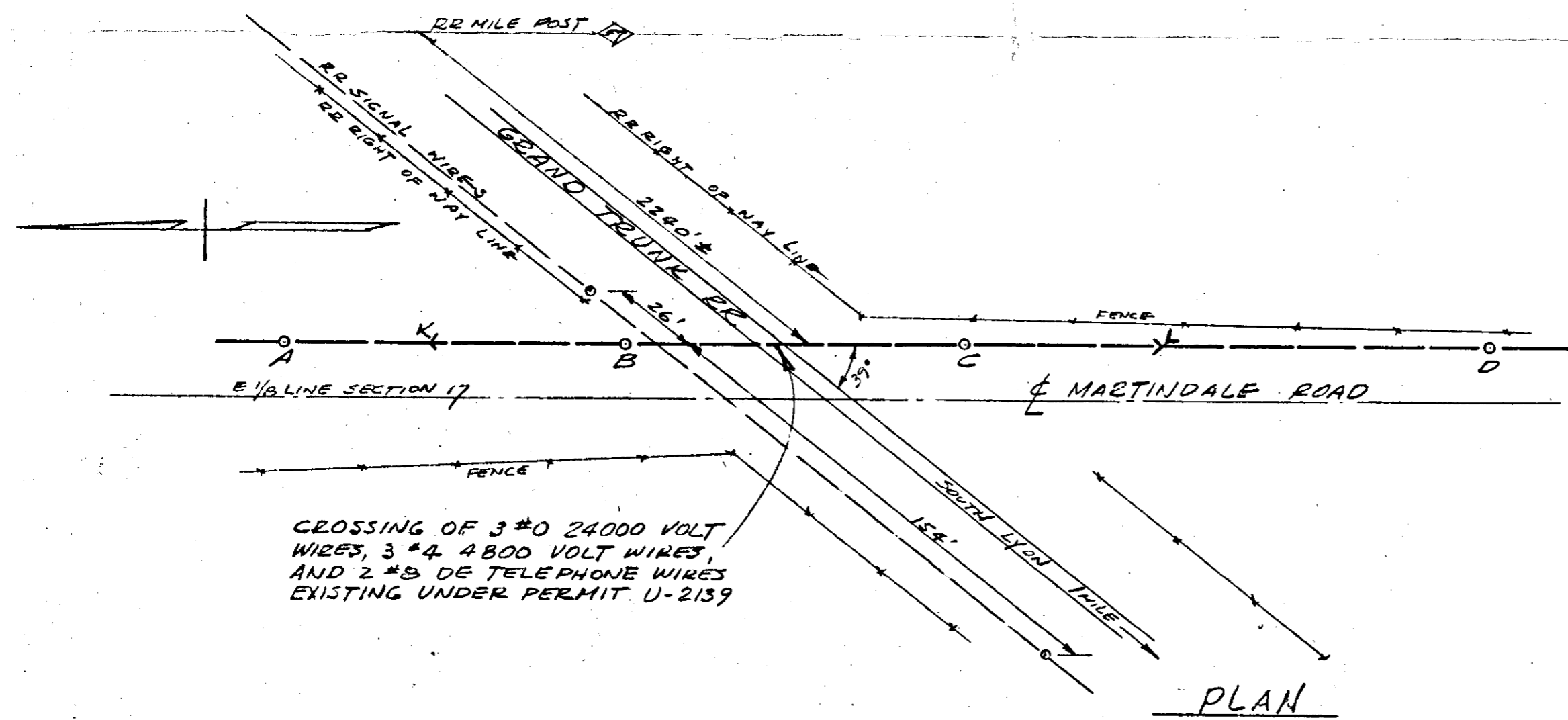
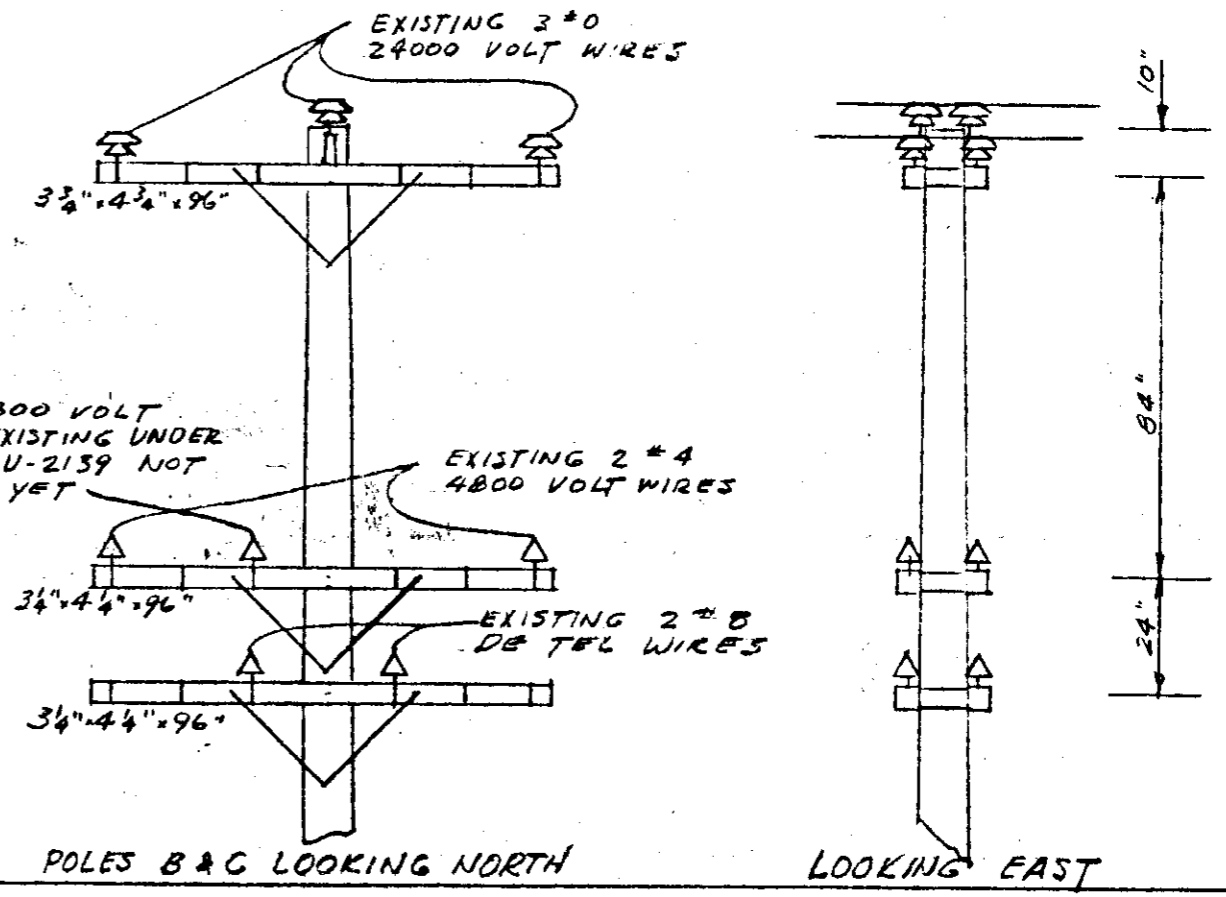
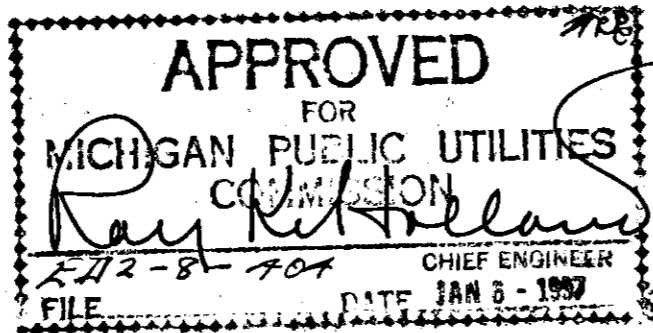

CROSSING OF 3 #0 24000 VOLT WIRES, 3 #4 4800 VOLT WIRES, AND 2 #8 DE TELEPHONE WIRES EXISTING UNDER PERMIT U-2139

PLAN

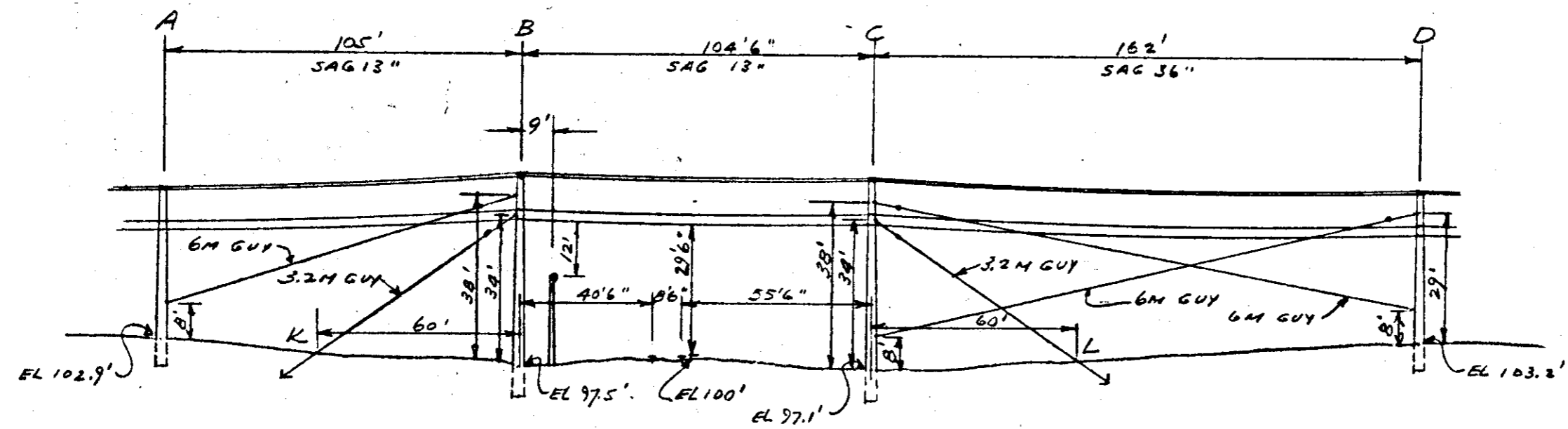

ELEVATION LOOKING EAST

DRAFTING & SURVEYING BUREAU RX 1644

RECORDED RIGHT OF WAY NO. 78  
34636  
p92