

THE DETROIT EDISON COMPANY

2000 SECOND AVENUE
DETROIT 26, MICHIGAN

D.O. E-62021
3/11/71

Michigan Public Service Commission ~~1971~~ **20, 1971**
Lansing 13, Michigan

Gentlemen:

The Detroit Edison Company, Detroit, Michigan, hereby makes application for authority to string the following wires over the tracks of the

Grand Trunk Western Railroad, S.E. 1/4 of Section 24, Waterford Township, T 3 N, R 9 E, Oakland County, Michigan.

Span C-D

One 3/8" Beth "C" steel shield wires, Three 350 B 40,000-volt wires, Three No. 350 B 13,200-volt wires, One No. 0 B neutral, One No. 0 A 120 volt wire, and One 25 pair system communication cable, over the tracks of The Grand Trunk Western Railroad located in private property (West Blvd. if extended) at a point approximately 1530 feet South of the center line of Dixie Highway, 32 feet West of the West limits of the City of Pontiac.

Mile Post 28.42

The proposed wire crossing will be constructed in accordance with specifications of the Michigan Public Service Commission and the construction standards of The Detroit Edison Company, approved by the Michigan Public Service Commission on July 19, 1939, File ED 2-9.01.

- Enclosed is a waiver of hearing granted by the Railroad Company.
- Waiver of hearing by the Railroad Company is covered by blanket waiver.
- This application covers reconstruction of existing crossing and will cancel and supersede wire crossing permit No. **ED2-8-5363** dated **7-8-64**
- This is a new crossing.

Reference number of construction drawing is RX-

2005D

CM:dmk

Yours very truly,

Permit No. ED2-8-6824

Date 7-1-71

By MPSC

I. W. Gamble
Supervisor of Rights of Way
Real Estate and Rights of Way Dep

Check in circle indicates statement applicable.

RECORDED RIGHT OF WAY NO. 34636
248

STATE OF MICHIGAN
BEFORE MICHIGAN PUBLIC SERVICE COMMISSION

Standard Railroad Wire-Crossing Permit No. **ED2-8-6813**

In Re Application of **The Detroit Edison Company**
2000 Second Avenue
Detroit, Michigan 48226

Pursuant to Act No. 171 of the Session Laws of 1893, as amended, application having been made to Michigan Public Service Commission by said **The Detroit Edison Company**

for permission to string wires across the tracks of the **Grand Trunk Western Railroad Company**

and said **The Detroit Edison Company** having conformed to the Commission's rules governing the filing of notices and issuing of permits for the construction of electrical lines and said rail road company having waived the right of notice and hearing provided for in said act **THEREFORE**, It is ordered that said

The Detroit Edison Company be permitted to string the following described wires across the tracks of said railroad at the following described place:

Township of
Waterford

County of
Oakland

State of
Michigan

Span B-C, crossing of one (1) 40 kV, 60 Hz, 3 phase, 3 wire, subtransmission circuit, with one (1) shield wire, one (1) 13.2 kV, 60 Hz, 3 phase, 4 wire, distribution circuit, with one (1) neutral conductor and one (1) 25 pr. system communication cable, on wood poles, located in private property (West Blvd. if extended) at a point approximately 1400' south of center line of Dixie Highway, 32' west of west limits of City of Pontiac, SE $\frac{1}{4}$ of Section 24, T3N, R9E
3 - 350 MCM bare aluminum phase conductors - 40 kV
1 - 3/8" Beth "C" steel shield wire
3 - 350 MCM bare aluminum phase conductors - 13.2 kV
1 - #1/0 bare aluminum neutral conductor
1 - 25 pr. system communication cable Per Drawing RE-2005D

RECORDED RIGHT OF WAY NO. 34636 p 248

as indicated on the attached plans, when, as and if approved.
At the point of crossing said wires shall be installed in accordance with this Commission's rules and regulations.

Given under our hands and the Official Seal of this Commission at the City of Lansing, State of Michigan, this **eighteenth** day of **June**
A.D. 19 **71**

MICHIGAN PUBLIC SERVICE COMMISSION

Willis F. Ward
.....
Chairman,

William A. Boos, Jr.
.....
Commissioner,

Lenton G. Sculthorp
.....
Commissioner.

Countersigned

Earl B. Klomprens
.....
Secretary

STATE OF MICHIGAN
BEFORE MICHIGAN PUBLIC SERVICE COMMISSION

ED2-8-6824

Standard Railroad Wire-Crossing Permit No.

In Re Application of **The Detroit Edison Company**
2000 Second Avenue
Detroit, Michigan 48226

Pursuant to Act No. 171 of the Session Laws of 1993, as amended, application having been made to Michigan Public Service Commission by said **The Detroit Edison Company**

for permission to string wires across the tracks of the **Grand Trunk Western Railroad Company**

and said **The Detroit Edison Company**

having conformed to the Commission's rules governing the filing of notices and issuing of permits for the construction of electrical lines and said railroad company having waived the right of notice and hearing provided for in said act **THEREFORE, It is ordered that said**

The Detroit Edison Company

be permitted to string the following described wires across the tracks of said railroad at the following described place: **Span C-D, crossing of one (1) 40 kv,**

Township of Waterford	60 Hz, 3 phase, 3 wire, subtransmission circuit, one (1) 13.2 kv,
County of Oakland	60 Hz, 3 phase, 4 wire, wye connected, distribution circuit, one (1) 120 volt, 60 Hz, single-phase, secondary circuit and one (1) 25 pr. system communication cable, on wood poles, with one (1) neutral conductor and one (1) shield wire, located in private property at a point in West Blvd. (if extended) approximately 1530' south of center line of Dixie Highway, 32' west of west limits of city of Pontiac, SE$\frac{1}{4}$ of Section 24, T3N, R9E
State of Michigan	3 - 350 MCM bare aluminum phase conductors - 40 kv
	3 - 350 MCM bare aluminum phase conductors - 13.2 kv
	1 - #1/0 covered aluminum phase conductor - 120 volt
	1 - 3/8" Beth "C" steel shield wire & 1 - #1/0 bare aluminum neutral conductor; 1 - 25 pr. communication cable

34636
p 2448

as indicated on the attached plans, when, as and if approved. **Per Drawing EX-2005D**
At the point of crossing said wires shall be installed in accordance with this Commission's rules and regulations.

Given under our hands and the Official Seal of this Commission at the City of Lansing, State of Michigan, this **first** day of **July** A.D. 19 **71**

MICHIGAN PUBLIC SERVICE COMMISSION

Willis F. Ward

.....
Chairman,

Lenton G. Sculthorp

.....
Commissioner,

Countersigned

Eari B. Klompars

.....
Secretary

.....
Commissioner.



Grand Trunk Western Railroad Co

W. P. Collins
 Manager of Real Estate & Tax

131 West Lafayette Boulevard
 Detroit, Michigan 48226

May 3, 1971

Mr. I. W. Gamble
 Supervisor of Rights of Way
 Real Estate and Rights of Way Dept.
 The Detroit Edison Company
 2000 Second Avenue
 Detroit, Michigan 48226

I. W. GAMBLE
 ls
 MAY 5 1971
 R/E & R/W DEPT.

Dear Mr. Gamble:

This will acknowledge receipt of your letter under date of March 12, 1971, addressed to our Engineer of Surveys and Construction, Mr. F. E. Rosenkrans, wherein you requested a waiver of hearing before the Michigan Public Service Commission for reconstruction of a wire crossing over Grand Trunk right of way at its Mile Post 28.42, at location you have described as in West Boulevard at a point approximately 1,000 feet South of the centerline of the Dixie Highway, 32 feet West of West limits of the City of Pontiac, S.E. 1/4 of Section 24, Waterford Township, Oakland County, Michigan, as shown on Plan RZ-2005-D, consisting of the following wires:

- 1 - 3/8" Beth "C" steel shield wire
- 3 - No. 350 B 40,000 volt wires
- 3 - No. 350 B 13,200 volt wires (Span B-C)
- 1 - No. 0 B neutral
- 1 - No. 0 A 120-volt wire
- 1 - 25 Pr. system communication cable

Inasmuch as you have stated that this reconstruction will be accomplished in accordance with rules and regulations of the Michigan Public Service Commission and as this Railroad Company has no objections to the crossing, The Detroit Edison Company is hereby granted a waiver of hearing. No facility markers or permit will be required inasmuch as this facility is located on private property.

Yours very truly,

T. Higley
 For: W. P. Collins
 Manager of Real Estate and Tax

34636 p 248

THE DETROIT EDISON COMPANY

2000 SECOND AVENUE

DETROIT, MICHIGAN 48226

TO:

March 12, 1971

Mr. F. E. Rosenkranz
Engineer of Surveys and Construction
Grand Trunk Western Railroad Company
Brush Street Depot
Corner of Brush Street and Atwater Street
Detroit, Michigan 48226

Proposed Overhead Wire Crossing:

One 3/8" Each "C" steel, shield wire, Three No. 350 B 40,000-volt wires,
Three No. 350 B 13,200-volt wires, One No. 0 B neutral, One No. 0 A 120-volt wire
and One 25 pair system communication cable. (Span B-C)

*GTW RR states this is Private
Property. We determined West
Blind ends just north of East
GT tracks. Property, not GT.*

Specific Location

pp
In West Boulevard at a point approximately 1400 feet South of the center line
of the Dixie Highway, 32 feet West of West limits of the City of Pontiac.

R. R. Valuation Station _____ R. R. Mile Post _____

City/Village _____ Township Waterford, S.E. 1/4 of Sec. 24

County Oakland Detroit Edison Plan Attached RK-2005D

This is a New Crossing _____ This is a Reconstruction of Existing Crossing X

Previous Agreement Information (if any) Date _____ (R. R. Plan) _____

Previous Waiver of Hearing File No. 4730-1-78

Blanket Waiver of Hearing Covers X Waiver of Hearing Requested in duplicate
(Waiver of Hearing to be mailed to applicant listed below)

All construction will be done in accordance with the rules and regulations of the Michigan Public Service Commission.

J. W. Gamble
I. W. Gamble, Supervisor of Rights of Way
Real Estate and Rights of Way Department

34636 p 2148

THE DETROIT EDISON COMPANY

2000 SECOND AVENUE

DETROIT, MICHIGAN 48226

TO:

March 15, 1971

Mr. F. E. Rosenkrans
Engineer of Surveys and Construction
Grand Trunk Western Railroad Company
Brush Street Depot
Corner of Brush Street and Atwater Street
Detroit, Michigan 48226

Proposed Overhead Wire Crossing:

One 3/8" each "C" steel shield wires, Three 350 B 40,000-volt wires, Three No. 350 B 13,200-volt wires, One No. 0 B neutral, One No. 0 A 120-volt wires, and One 25 pair system communication cable. (Span C-D)

*See Span B-C
note*

Specific Location

P P

In **WEST Boulevard** at a point approximately 1530 feet South of the center line of **Dixie Highway**, 32 feet West of the West limits of the City of Pontiac.

R. R. Valuation Station _____ R. R. Mile Post 2240 feet N.W. of M.P. 28

City/Village _____ Township Waterford, S.E. 1/4 of Sec. 24

County Oakland Detroit Edison Plan Attached RX-2003D

This is a New Crossing _____ This is a Reconstruction of Existing Crossing

Previous Agreement Information (if any) Date _____ (R. R. Plan) _____

~~Previous Waiver of Hearing File No. 4730-1-78~~

Blanket Waiver of Hearing Covers Waiver of Hearing Requested in duplicate
(Waiver of Hearing to be mailed to applicant listed below)

All construction will be done in accordance with the rules and regulations of the Michigan Public Service Commission.

I. W. Gamble

I. W. Gamble, Supervisor of Rights of Way
Real Estate and Rights of Way Department

CN:dkk

34436 p 248

No. 2005 D
 D.O.B. 62,044
 PERMIT NUMBER 2-333 (C)
 32 N. OF THE WEST CORNER OF
 THE CENTRELINE OF DRAIG HWY (05-10)
 SECTION 22 3E 19 TOWNSHIP WATERFORD T 34 R 18 COUNTY OAKLAND
 CITY OF EASTLAND

CONDUCTORS				POLES			
NUMBER	SIZE	VOLTAGE	LOCATION	LENGTH	CLASS	TYPE	
1	350 MB	40,000 V	A	50	3	WOOD	
2	350 MB	40,000 V	B	75	2	" "	
3	350 MB	40,000 V	C	50	3	" "	
4	350 MB	40,000 V	D	75	2	" "	
5	350 MB	40,000 V	E	50	3	" "	
6	350 MB	40,000 V	F	75	2	" "	
7	350 MB	40,000 V	G	45	2	" "	
8	350 MB	40,000 V	H	65	3	" "	

NOTES:
 MATERIALS SHALL BE AS NOTED IN THE DETROIT Edison COMPANY'S GENERAL SPECIFICATIONS FOR OVERHEAD LINE CONSTRUCTION AS RAILROAD CROSSINGS DATED MARCH 1928.
 ACTUAL TOWER HEIGHTS MAY VARY SLIGHTLY FROM THOSE SHOWN BUT THE HEIGHTS OF WIRE ABOVE GROUND SHALL BE AS SHOWN. SERVICE CONNECTIONS TO BE MADE JAN. 1, 1934. ALL WIRE SHALL BE NEW.

MINIMUM CLEARANCES:
 WIRE OVER PASSENGER TRAINS: 7 FT
 WIRE OVER HIGHWAYS: 12 FT
 WIRE OVER RAILROADS: 27 FT
 WIRE OVER POWER LINES:
 0-750 VOLTS: 27 FT
 750-15,000 VOLTS: 28 FT
 15,000-50,000 VOLTS: 30 FT
 WIRE OVER RAILROAD SIGNALS:
 0-750 VOLTS: 8 FT
 750-15,000 VOLTS: 10 FT
 15,000-50,000 VOLTS: 12 FT

REV. D WKS 8-5-71
 EST. S. KRINSKY POINT SEC. CTR.
 DESIGNED BY H. GEPPERT
 ESTIMATED BY G. WEST
 DATE 6-22-48
 PROJECT ENGINEERING DEPT.
 PANT. SER. CTR.

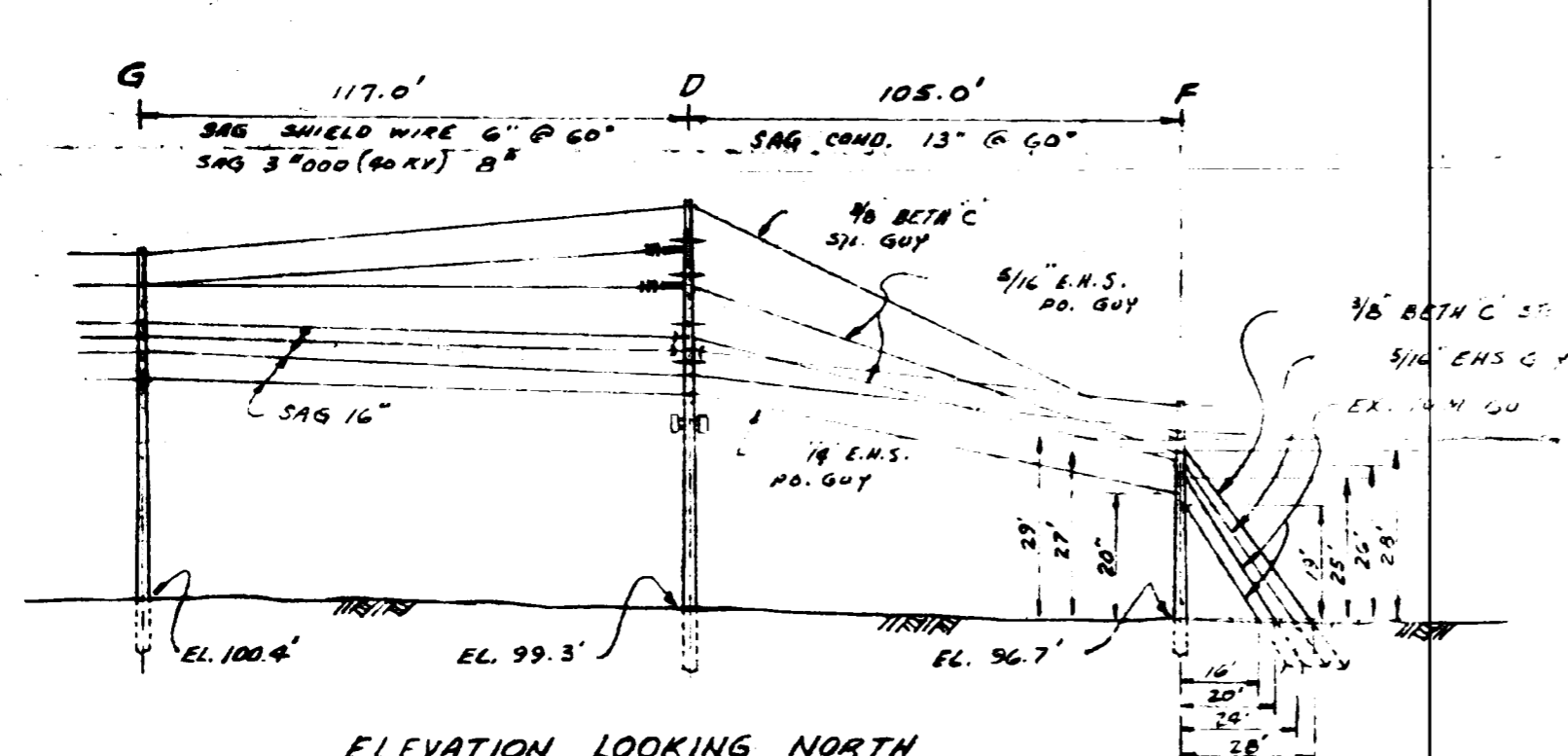
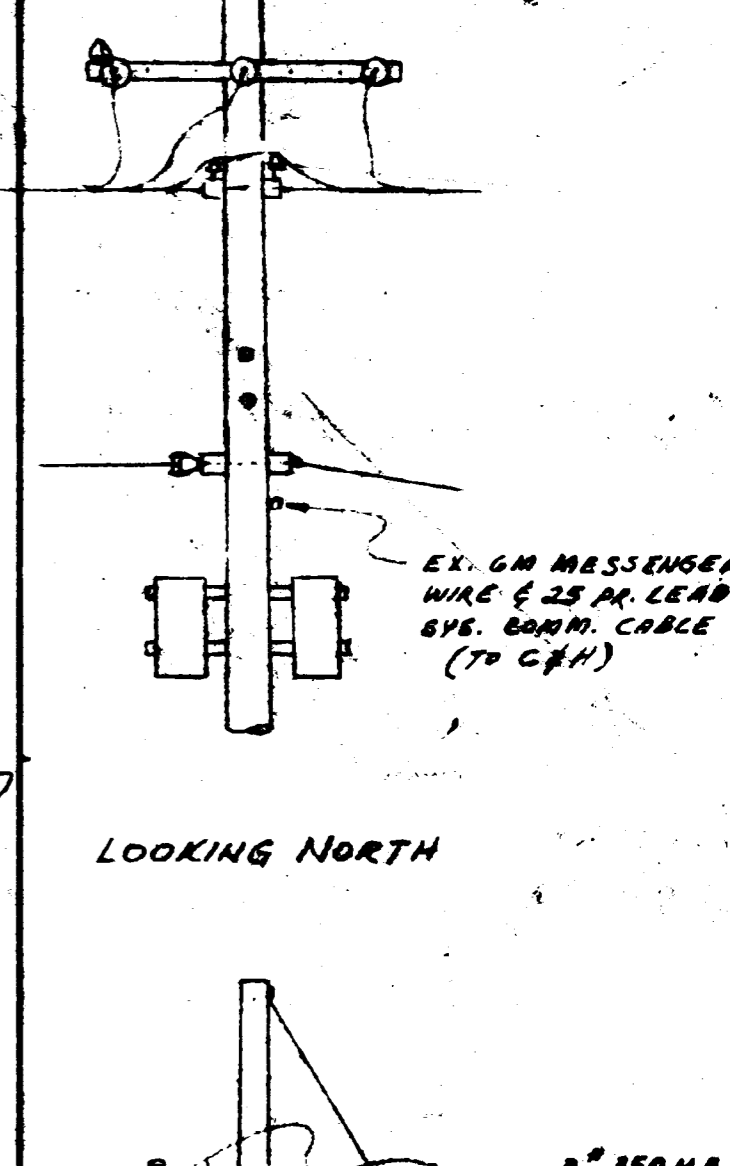
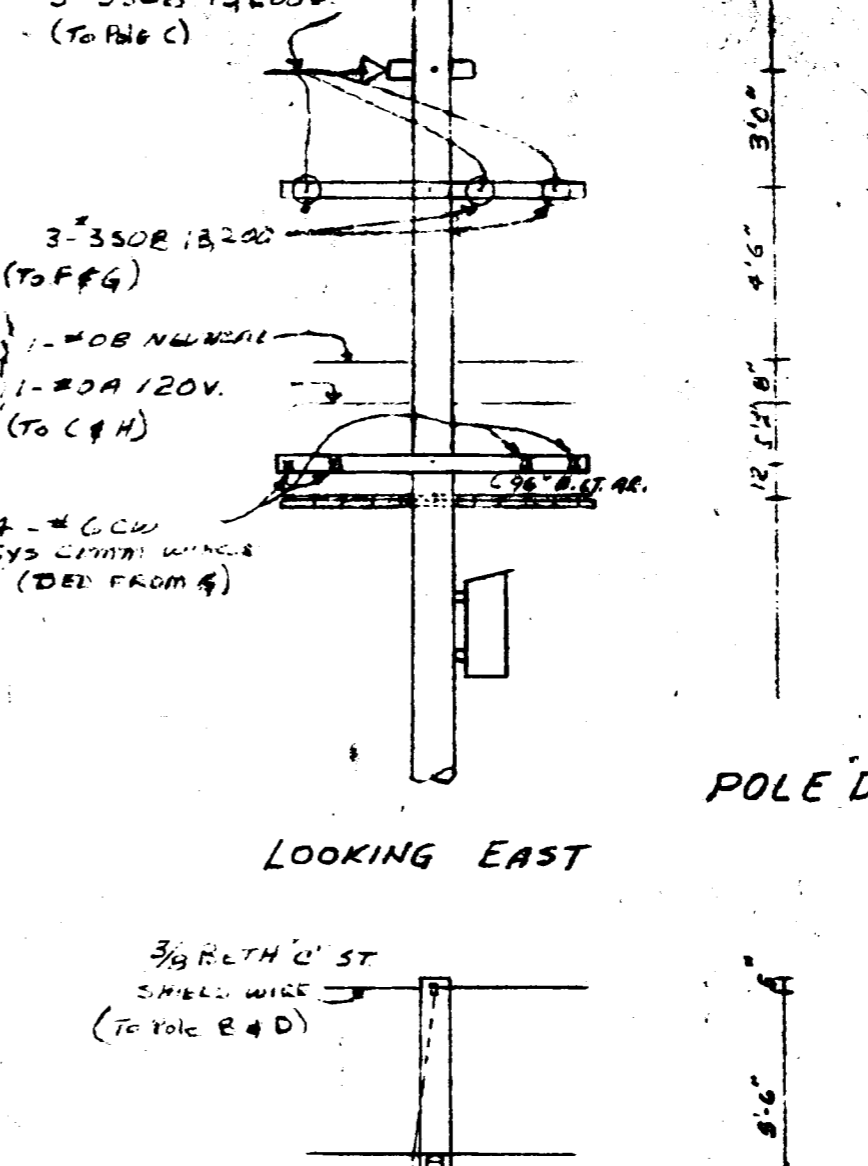
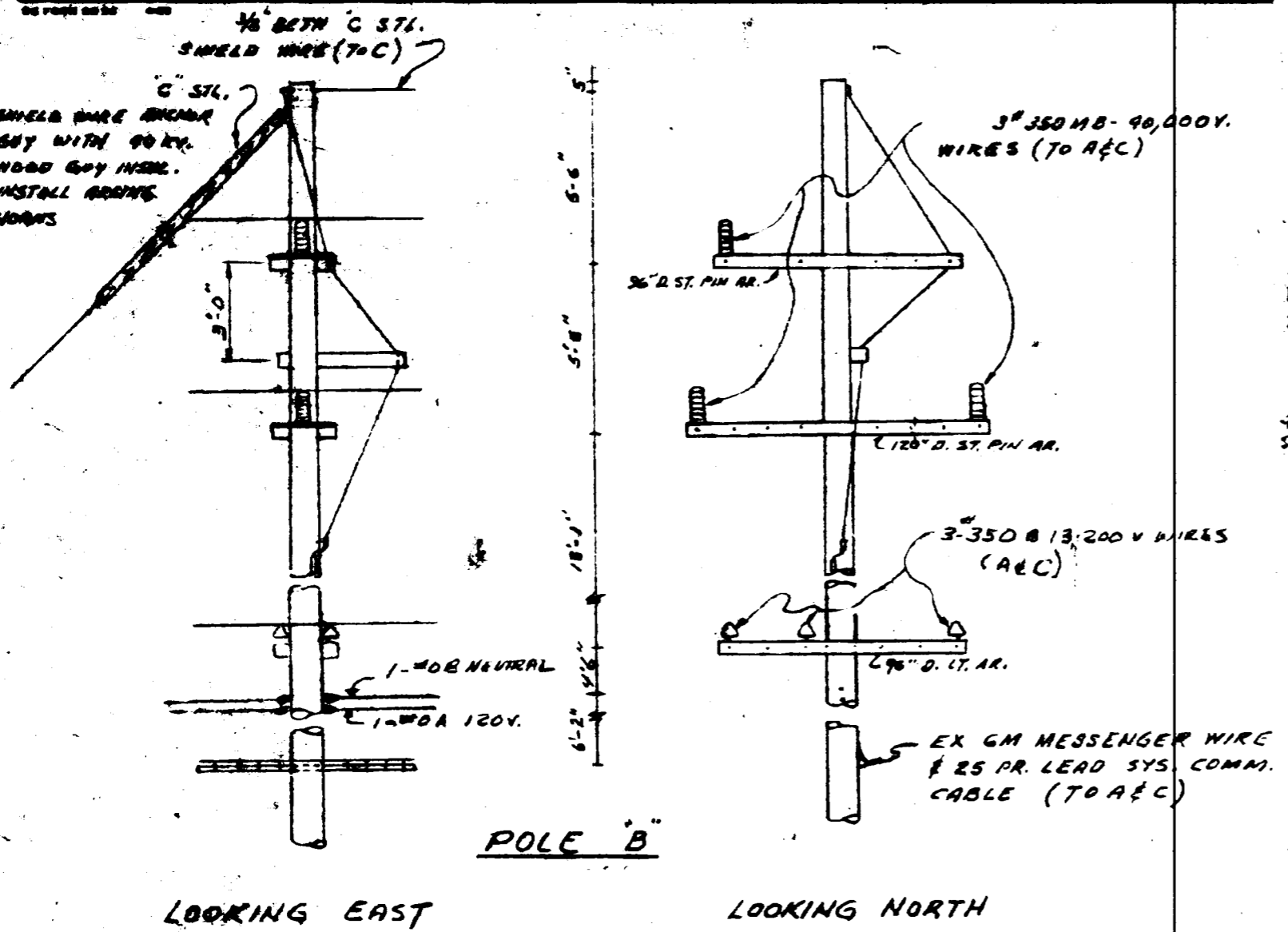

APPROVED
 FOR
 MICHIGAN PUBLIC SERVICE
 COMMISSION
 DIRECTOR OF PUBLIC UTILITIES
 FILE ED2-8-6813 DATE 6-18-71

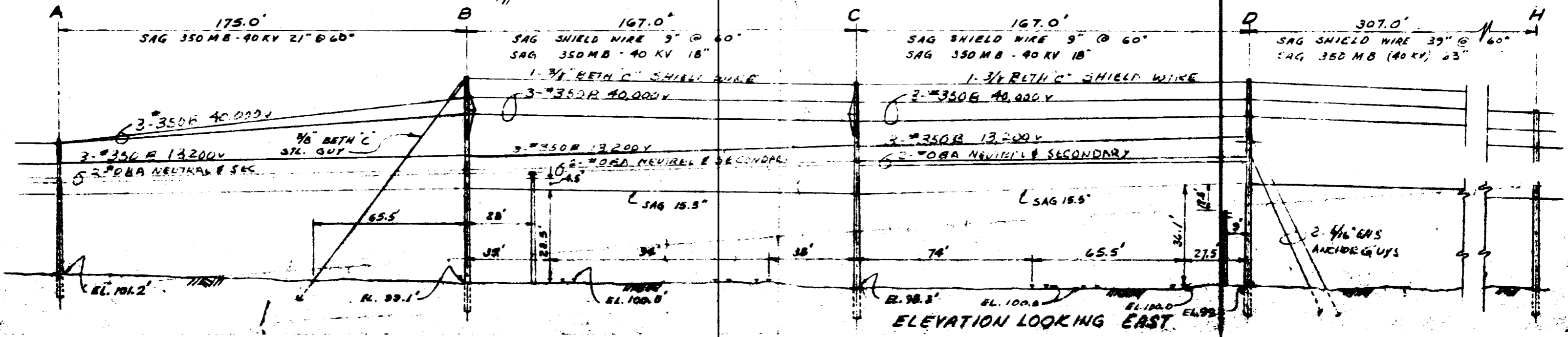
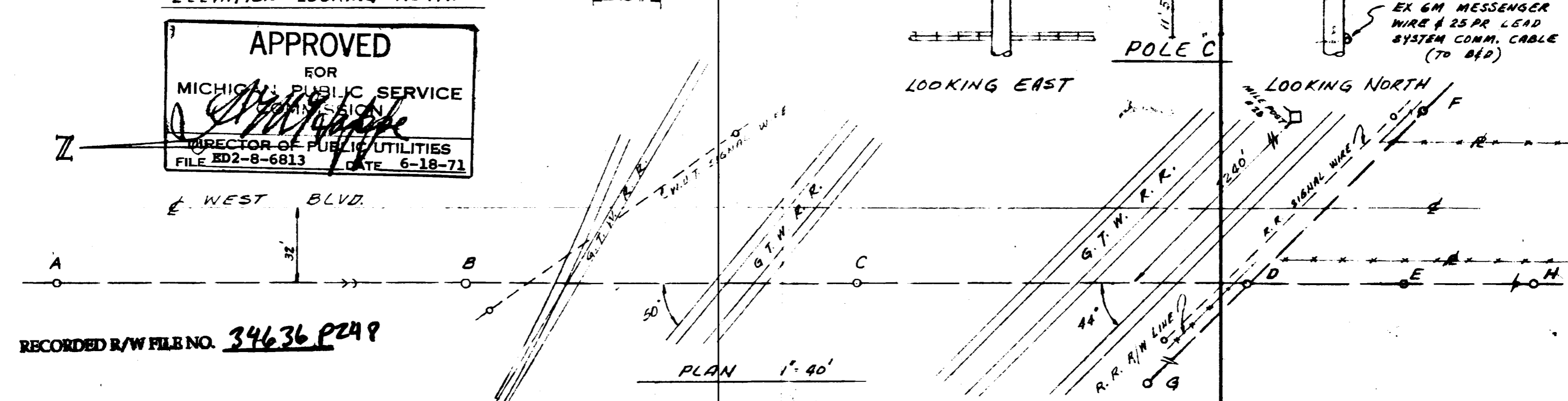

RECORDED R/W FILE NO. 34636 P249

PROPOSED LINE CROSSING OVER **G.T.W. TRUNK WESTERN R.R.** IN **WEST BLVD. APPROX. 1000' AND 1630' SOUTH OF THE CENTERLINE OF DIXIE HWY (US-10)** CITY OF **PONTIAC** SECTION **24 SE 1/4** TOWNSHIP **WATERFORD** T **3N R 9E** COUNTY **OAKLAND**

RX 2005 D
 402-B-5362 (8-5)
 EX. STING PERMIT NUMBER 22-3363 (G-D)
 32 W. OF THE WEST LIMITS OF

CONDUCTORS		POLES					
NUMBER	SIZE	KIND	VOLTAGE	LOCATION	LENGTH	CLASS	TYPE
1	3/8"	BETH C	SH. WIRE	B-C	75	3	H
3	25L	B	40,000V	D	75	2	"
3	350	B	13,200V	E	50	2	"
1	0	B	NEUTRAL	F	45	4	"
1	0	A	120V	G	65	2	"
1	25PR	SYS. COMM.		H	65	3	H

NOTES
 MATERIALS SHALL BE AS NOTED IN THE DETROIT EDISON COMPANY'S GENERAL SPECIFICATIONS FOR OVERHEAD LINE CONSTRUCTION AT RAILROAD CROSSINGS DATED MARCH 1938
 ACTUAL FIELD DIMENSIONS MAY VARY SOMEWHAT FROM THOSE SHOWN BUT THE REQUIREMENTS OF ORDER NO. 1078 OF MICHIGAN PUBLIC SERVICE COMMISSION AS REVISED JAN. 1, 1944, WILL BE COMPLIED WITH

MINIMUM CLEARANCES
 NEAREST POLE TO RAIL: BIDDING 7 FT, MAIN LINE 12 FT
 WIRES OVER TRACKS: 0-750 VOLTS 27 FT, 750-15,000 VOLTS 28 FT, 15,000-50,000 VOLTS 30 FT
 WIRES OVER R.R. SIGNAL: 0-750 VOLTS 2 FT, 750-8,700 VOLTS 4 FT, 8,700-50,000 VOLTS 6 FT

DESIGNED BY **H. GEPPERT** PLANNING & PROJECT ENGINEERING DEPT. DATE **6-22-49**
 ESTIMATOR **G. WEST** OVERHEAD LINES DEPT. PONT. SER. CTR.

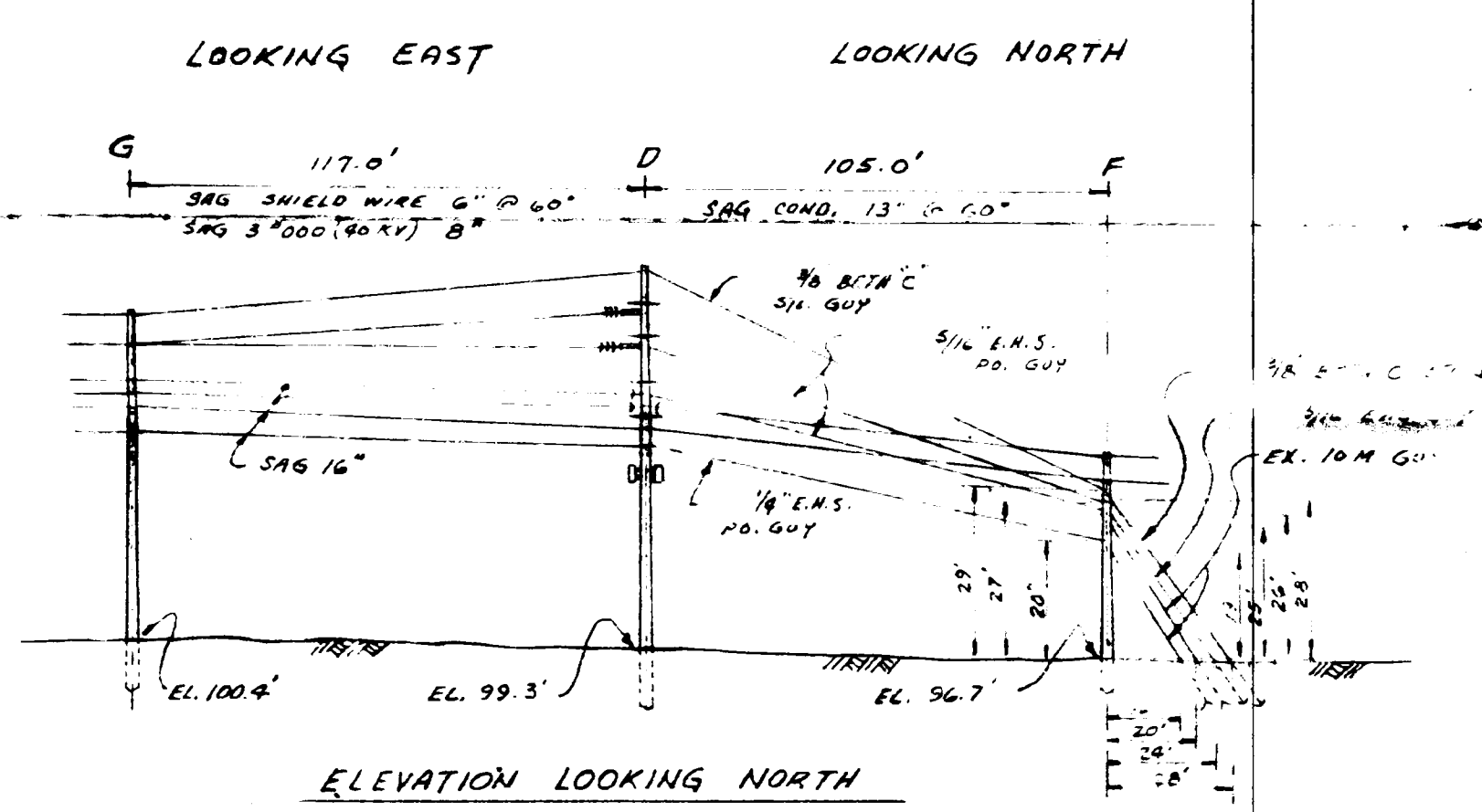
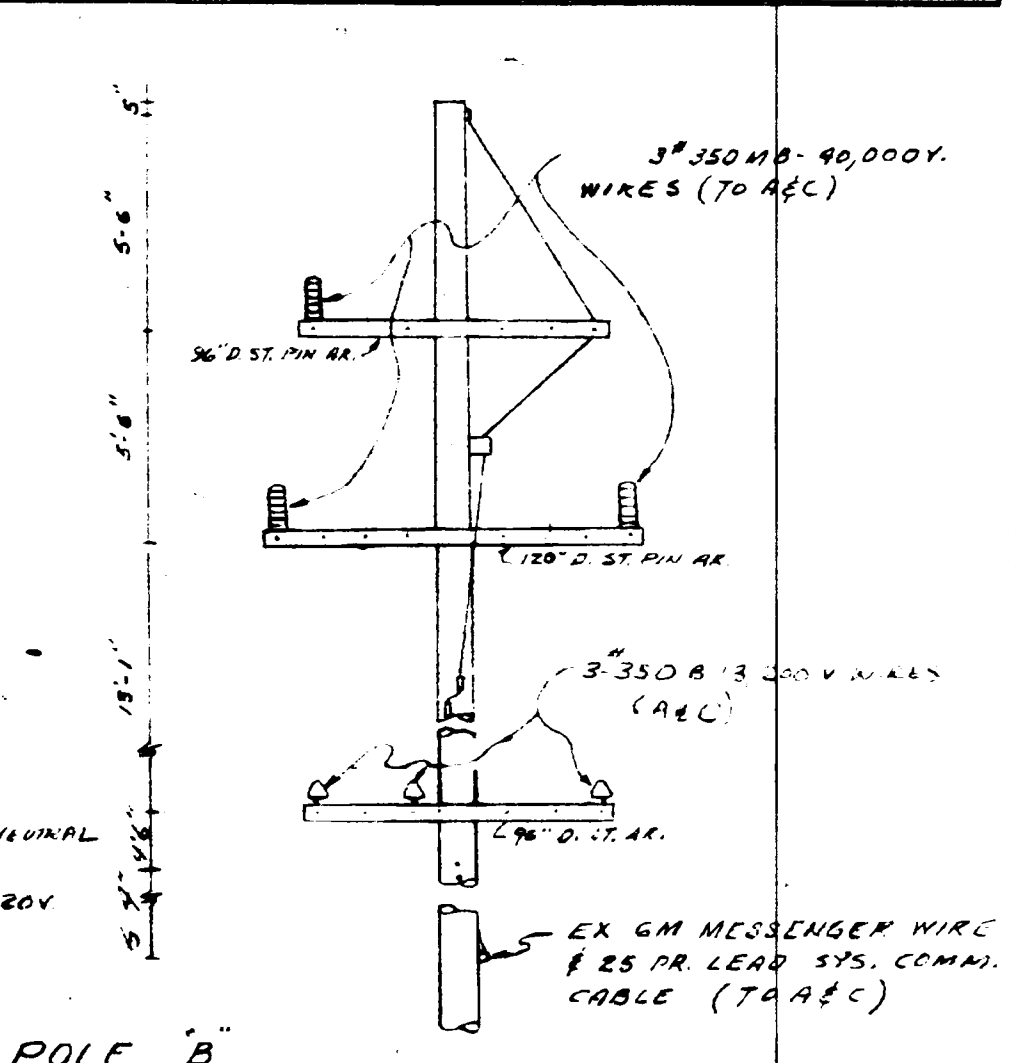
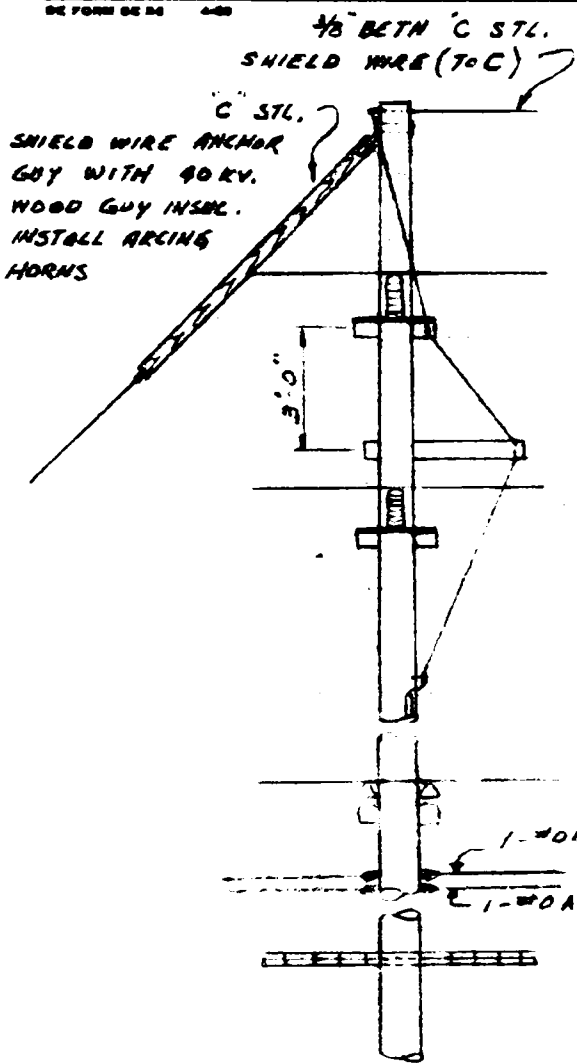

RECORDED R/W FILE NO. **34636 P248**

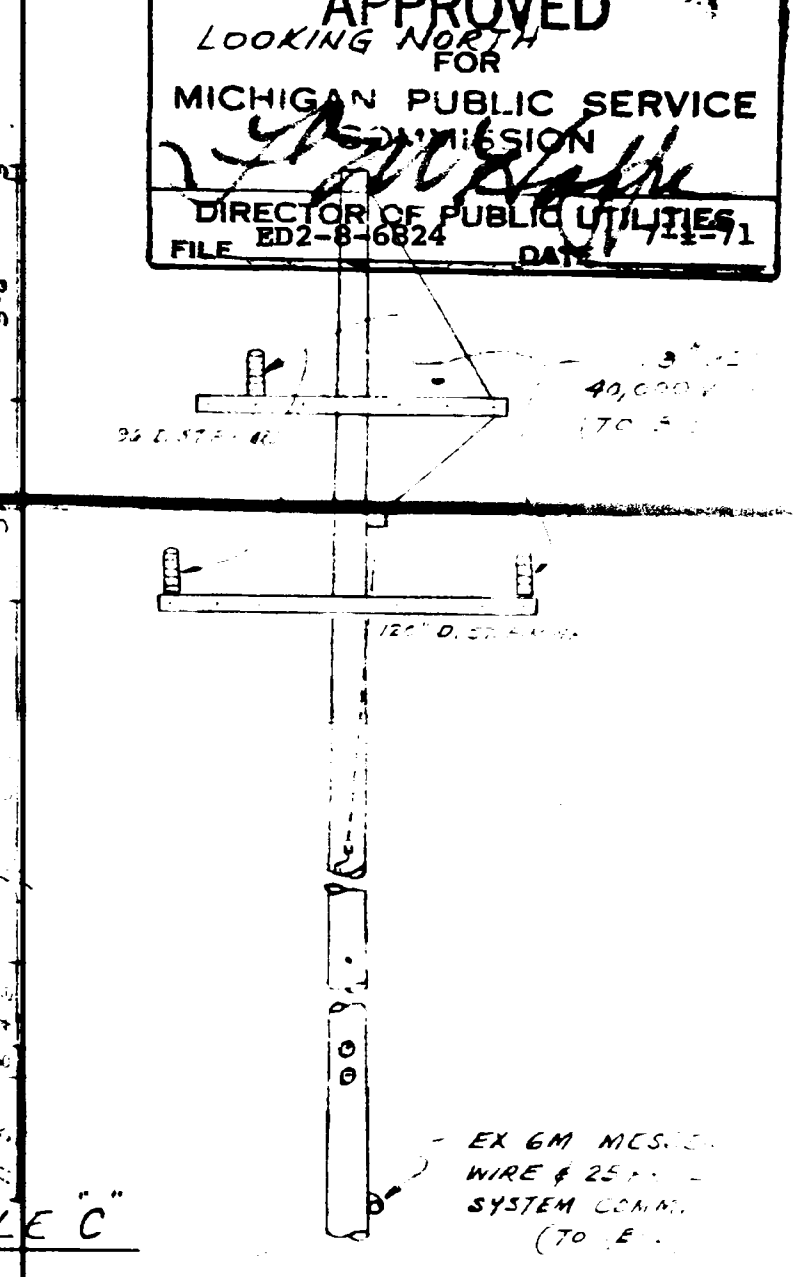
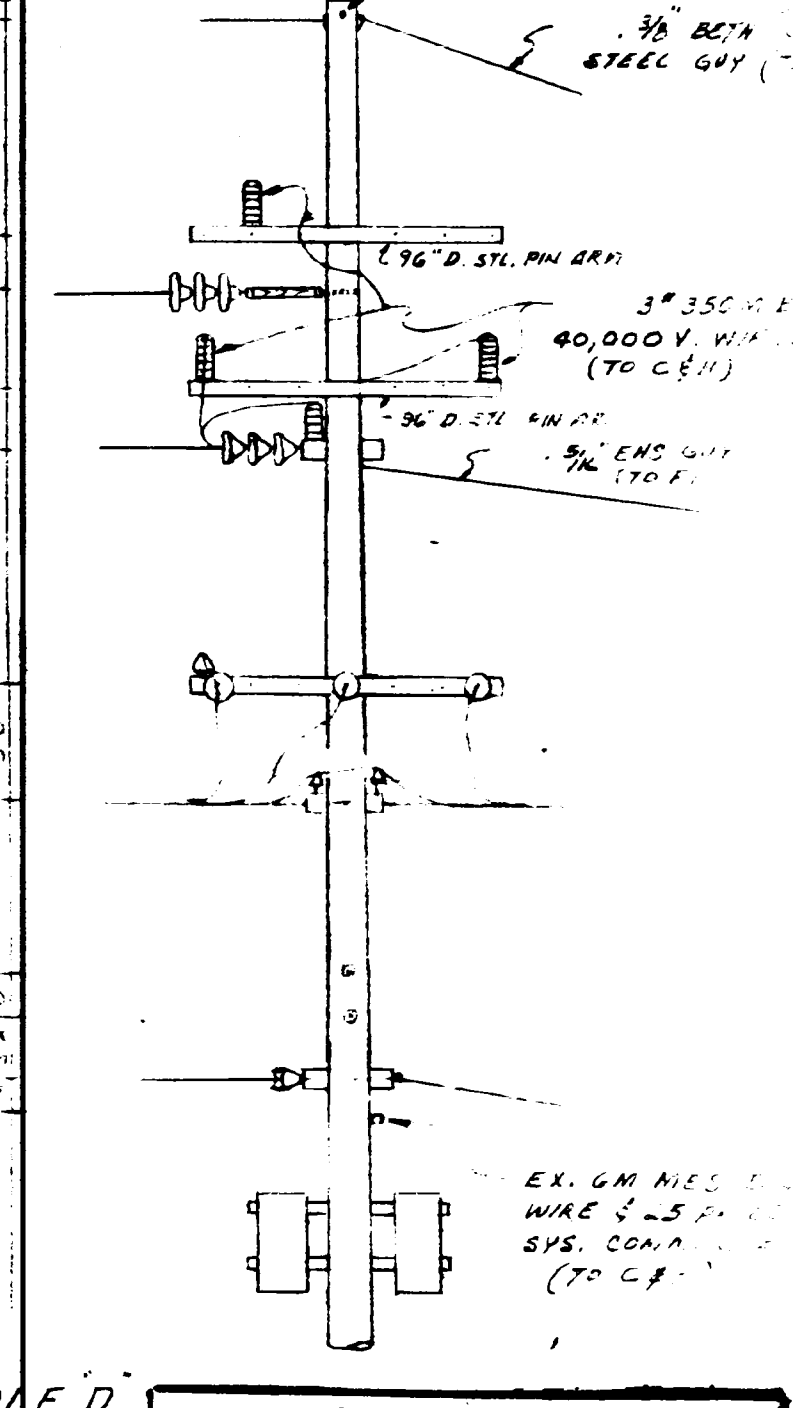
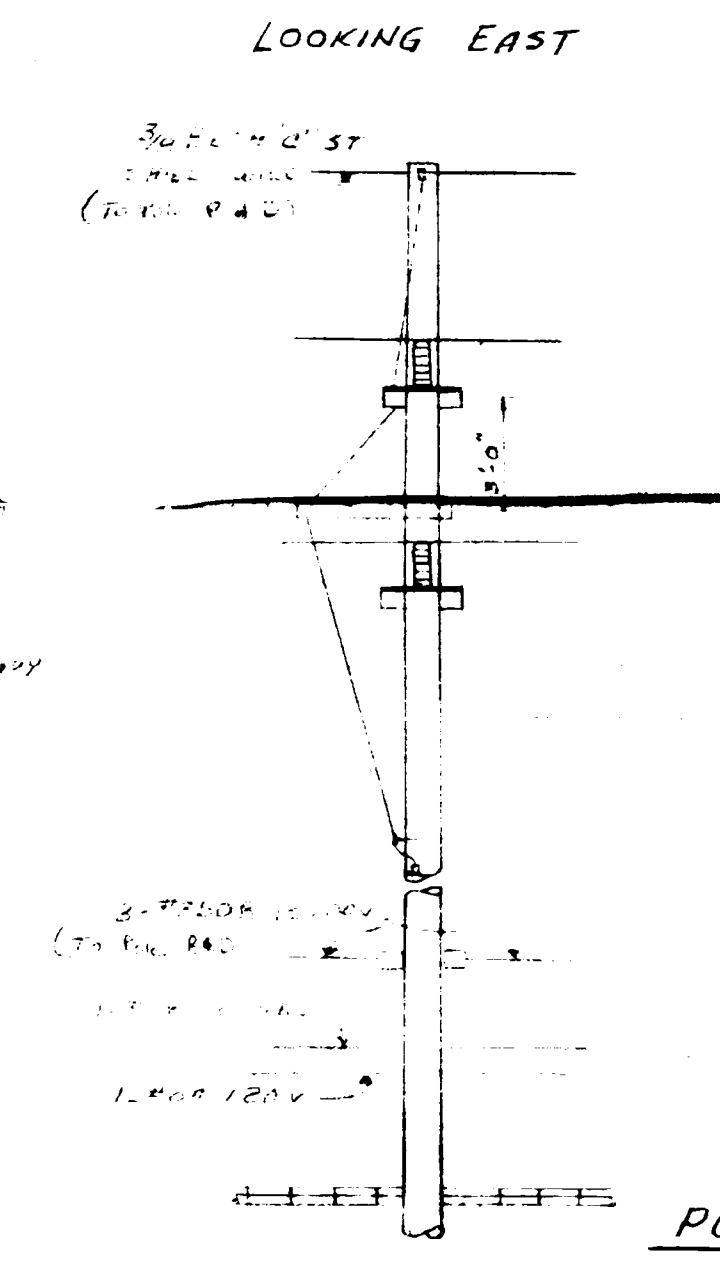
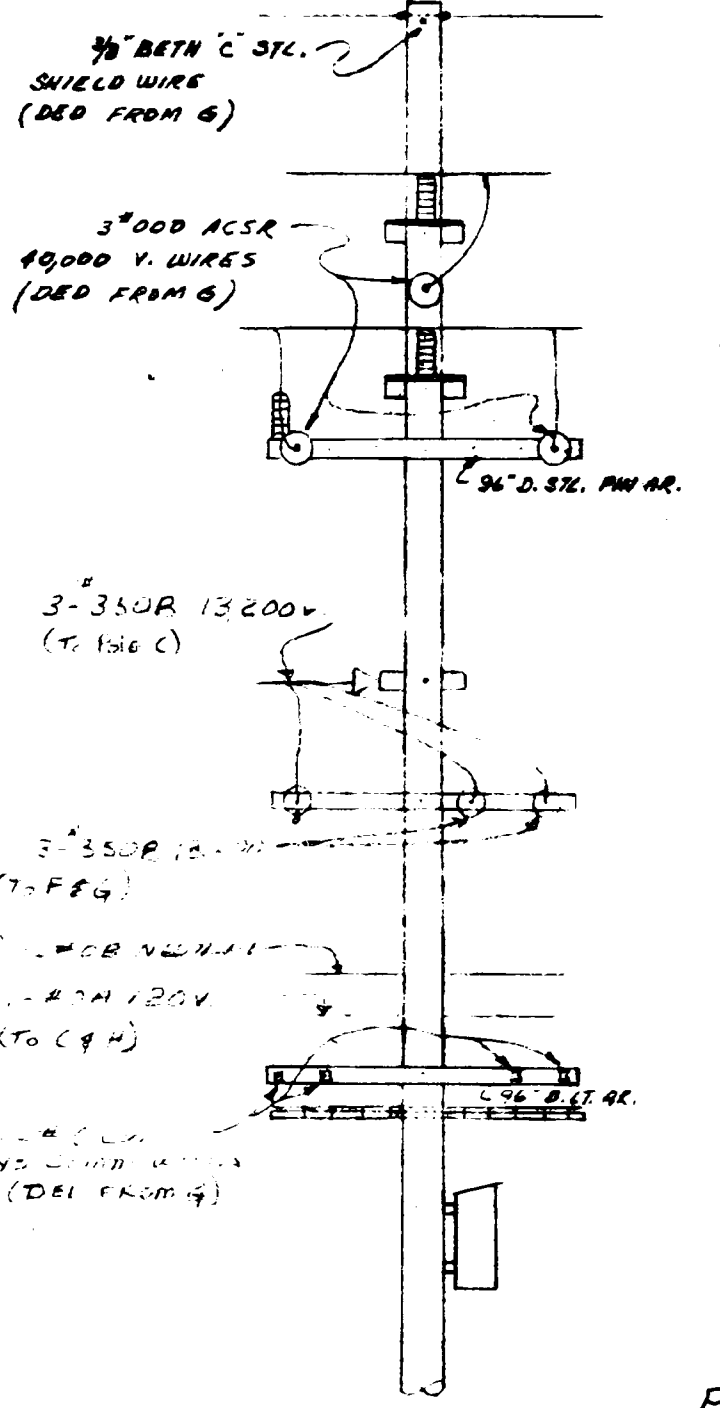
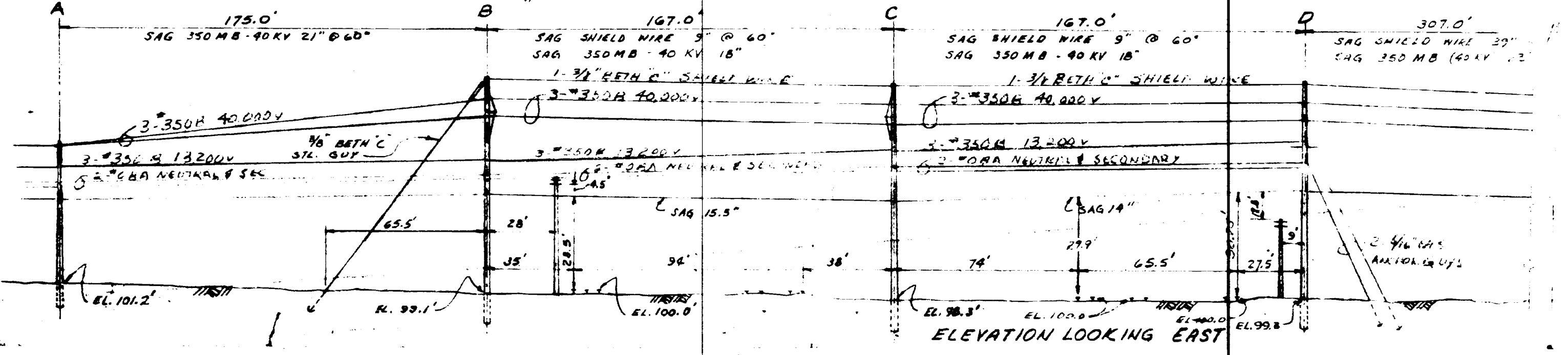
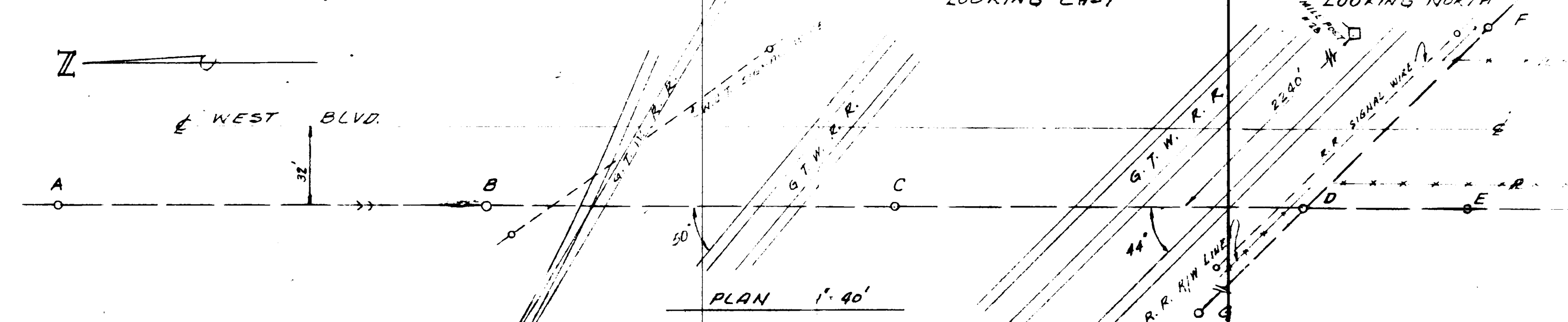

APPROVED
 LOOKING NORTH FOR
 MICHIGAN PUBLIC SERVICE COMMISSION
 DIRECTOR OF PUBLIC UTILITIES
 FILE 8D2-6-6824 DATE 7-1-51

THE DETROIT EDISON COMPANY

2000 SECOND AVENUE
DETROIT 26, MICHIGAN

D.O. B62021
3/11/71

May 20, 1971

Michigan Public Service Commission
Lansing 13, Michigan

Gentlemen:

The Detroit Edison Company, Detroit, Michigan, hereby makes application for authority to string the following wires over the tracks of the **Grand Trunk Western Railroad, S.E. 1/4 of Section 24, Waterford Township, T 3 N, R 9 E, Oakland County, Michigan.**

Span B-C

One 3/8" Bath "C" steel, shield wire, Three No. 350 B 40,000-volt wires, Three No. 350 B 13,200-volt wires, One No. O B neutral, One No. O A 120 volt wire and One 25 pair system communication cable over the tracks of the Grand Trunk Western Railroad, located in private property (West Blvd. if extended) at a point approximately 1400 feet South of the center line of the Dixie Highway, 32 feet West of West limits of City of Pontiac.

Mile Post 28.42

The proposed wire crossing will be constructed in accordance with specifications of the Michigan Public Service Commission and the construction standards of The Detroit Edison Company, approved by the Michigan Public Service Commission on July 19, 1939, File ED 2-9.01.

- Enclosed is a waiver of hearing granted by the Railroad Company.
- Waiver of hearing by the Railroad Company is covered by blanket waiver.
- This application covers reconstruction of existing crossing and will cancel and supersede wire crossing permit No. **ED2-8-5362** dated **7-8-64**
- This is a new crossing.

CM:dmk Reference number of construction drawing is RX- 2005D

Yours very truly,

Permit No. ED2-8-6813
Date 6-18-71
By MPSC



I. W. Gamble
Supervisor of Rights of Way
Real Estate and Rights of Way Dept.

Check in circle indicates statement applicable.

RECORDED RIGHT OF WAY NO. 34636
P 248



Grand Trunk Western Railroad Co

W. P. Collins
Manager of Real Estate & Tax

131 West Lafayette Boulevard
Detroit, Michigan 48226

May 3, 1971

I. W. GAMBLE

[Handwritten signature]
MAY 5 1971
R/E & R/W DEPT;

Mr. I. W. Gamble
Supervisor of Rights of Way
Real Estate and Rights of Way Department
The Detroit Edison Company
2000 Second Avenue
Detroit, Michigan 48226

Dear Mr. Gamble:

This will acknowledge receipt of your letter under date of March 15, 1971, addressed to our Engineer of Surveys and Construction, Mr. F. E. Rosenkrantz, wherein you requested a waiver of hearing before the Michigan Public Service Commission for reconstruction of a wire crossing over Grand Trunk right of way at its Mile Post 28.42, at location you have described as in West Boulevard at a point approximately 1530 feet South of the center line of Dixie Highway, 32 feet West of the West limits of the City of Pontiac, 2240 feet N.W. of N.P. 28, S.E. 1/4 of Section 24, Waterford Township, Oakland County, Michigan, as shown on Plan RX-2005-D, consisting of the following wires:

- 1 - 3/8" Beth "C" steel shield wires
- 3 - 350 B 40,000 - volt wires
- 3 - No. 350 B 13,200 - volt wires (Span C-D)
- 1 - No. 0 B neutral
- 1 - No. A 120 - volt wires
- 1 - 25 Pr. system communication cable

Inasmuch as you have stated that this reconstruction will be accomplished in accordance with rules and regulations of the Michigan Public Service Commission and as this Railroad Company has no objections to the crossing, The Detroit Edison Company is hereby granted a waiver of hearing. No facility markers or permit will be required inasmuch as this facility is located on private property.

Yours very truly,

[Handwritten signature]
For: W. P. Collins
Manager of Real Estate and Tax

RECORDED RIGHT OF WAY NO.