

GRAND TRUNK WESTERN RAILROAD COMPANY  
CHICAGO DIVISION

A. G. THERNSTROM  
SUPERINTENDENT

U-6 AM 8 41

(D) BATTLE CREEK, MICH., July 2, 1959  
File 4730-816

REAL ESTATE AND  
RIGHTS-OF-WAY DEPT.

The Detroit Edison Company  
2000 Second Avenue  
Detroit 26, Michigan

Attention: Mr. I. W. Gamble  
Supervisor of Rights of Way  
Real Estate and Rights of Way Dept.

Gentlemen:

Replying to your letter of June 19, 1959, advising of your proposal to add certain installations to existing wire crossing located over our tracks at a point in 10th Avenue, 73 feet South of the center line of Thomas Street in the City of Port Huron, Michigan, Northeast 1/4 of Section 3, Port Huron Township, St. Clair County, Michigan.

The construction as shown in your plan RX-746B dated June 16, 1959, has been checked and there are no objections to your making this installation with the understanding that the construction will be in accordance with your drawing and the specifications of the Commission.

You may use this letter as our waiver of hearing in your application to the Michigan Public Service Commission for permit.

Very truly yours,

*A. G. Thernstrom*  
Superintendent

ml

34636  
p156

no sewer not needed  
on this crossing. c.j

June 19, 1959

Mr. Albert G. Thernstrom  
Superintendent  
Grand Trunk Western Railroad Company  
Battle Creek, Michigan

Dear Mr. Thernstrom:

Kindly accept this as the proper notice that we propose to add one 5/16 inch EHS arm guy wire and one 3/16 inch EHS arm guy wire to the existing crossing of three #0 THWP 4800 volt wires and two #6 THWP street lighting wires (Span B-C) located over your tracks in 10th Avenue at a point 73 feet South of the center line of Thomas Street in the City of Port Huron, Northeast 1/4 of Section 3, Port Huron Township, St. Clair County, Michigan.

Attached are four (4) copies of our Plan RX-746B, showing location and other details of the proposed revision.

All construction will be done in accordance with the rules and regulations of the Michigan Public Service Commission.

This is in accordance with your blanket waiver of hearing covering crossings in public highways.

Yours very truly,

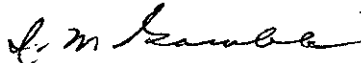

I. W. Garble  
Supervisor of Rights of Way  
Real Estate and Rights of Way Dept.

IWG:clj  
Attached

RECORDED RIGHT OF WAY NO.

34636  
p/56

THE DETROIT EDISON COMPANY

2000 SECOND AVENUE  
DETROIT 26, MICHIGAN

June 19, 1959

REAL ESTATE AND  
RIGHTS-OF-WAY DEPT.

Michigan Public Service Commission  
Lansing 13, Michigan

Gentlemen:

The Detroit Edison Company, Detroit, Michigan, hereby makes application for authority to string the following wires over the tracks of the Grand Trunk Western R.R. in the City of Port Huron, NE 1/4 of Section 3, Port Huron Twp., St. Clair County, T-6N, R-17E.

Three #0 THWP 4800 volt wires, two #6 TBWP street lighting wires, one 5/16" EHS arm guy wire and one 3/16" EHS arm guy wire over the track of the G.T.W.R.R. located in 10th Ave. at a point 73' south of the centerline of Thomas St.

The proposed wire crossing will be constructed in accordance with specifications of the Michigan Public Service Commission and the construction standards of The Detroit Edison Company, approved by the Michigan Public Service Commission on July 19, 1939, File ED 2-9.01.

Enclosed is a waiver of hearing granted by the Railroad Company.

Waiver of hearing by the Railroad Company is covered by blanket waiver.

This application covers reconstruction of existing crossing and will cancel and supersede wire crossing permit No. ED 2-8-1015 dated 10-25-39.

This is a new crossing.

Reference number of construction drawing is RX- 746B.

Yours very truly,

*I. W. Gamble*

I. W. Gamble  
Supervisor of Rights of Way

Permit No. ED2-8-4604

Date 6-22-59

*F. M. Hoppe*

Check in circle indicates statement applicable.

34636  
p156

**THE DETROIT EDISON COMPANY**

THE 1<sup>ST</sup> ESPEAKE OHIO R.R.  
THE C. AND TRUNK WESTERN R.R.

RX 746 B  
ED 2-8-1014  
ED 2-8-1015

PROPOSED LINE CROSSING OVER  
IN THE INTERSECTION OF THOMAS AND 10<sup>TH</sup> AVE. AND IN  
10<sup>TH</sup> AVE. 73' SOUTH OF THE E. OF THOMAS ST.  
SECTION 3 N.E. 1/4 TOWNSHIP PORT HURON (14) T 6N R 17E COUNTY ST. CLAIR  
EXISTING PERMIT NUMBER CITY OF PORT HURON

**NOTES**

MATERIALS SHALL BE AS NOTED IN THE DETROIT EDISON COMPANY'S GENERAL SPECIFICATIONS FOR OVERHEAD LINE CONSTRUCTION AT RAILROAD CROSSINGS DATED MARCH 1955.

ACTUAL FIELD DIMENSIONS MAY VARY SOMEWHAT FROM THOSE SHOWN BUT THE REQUIREMENTS OF ORDER NO. 1679 OF MICHIGAN PUBLIC SERVICE COMMISSION AS REVISED JAN. 1, 1944, WILL BE COMPLIED WITH

**MINIMUM CLEARANCES**

NEAREST POLE TO RAIL	SIDING	7 FT
	MAIN LINE	12 FT
WIRES OVER TRACKS	0 - 750 VOLTS	27 FT
	750 - 15,000 VOLTS	28 FT
	15,000 - 50,000 VOLTS	30 FT
WIRES OVER R R SIGNAL	0 - 750 VOLTS	2 FT
	750 - 8,700 VOLTS	4 FT
	8,700 - 50,000 VOLTS	6 FT

CONDUCTORS				POLES			
NUMBER	SIZE	KIND	VOLTAGE	LOCATION	LENGTH	CLASS	TYPE
3	#0	TOWP	4800	A-C-E	45'	3	WOOD
2	#6	"	ST. L.T.G.	B	50'	2	"
1	3/16" EHS	GUY WIRE	"	D	45'	1	"
1	3/16" EHS	"	"	"	"	"	"

DESIGNED BY J. WHYTE PLANNING & PROJECT ENGINEERING DEPT. DATE 6-16-59  
ESTIMATOR V. BROWN OVERHEAD LINES DEPT. PORT HURON

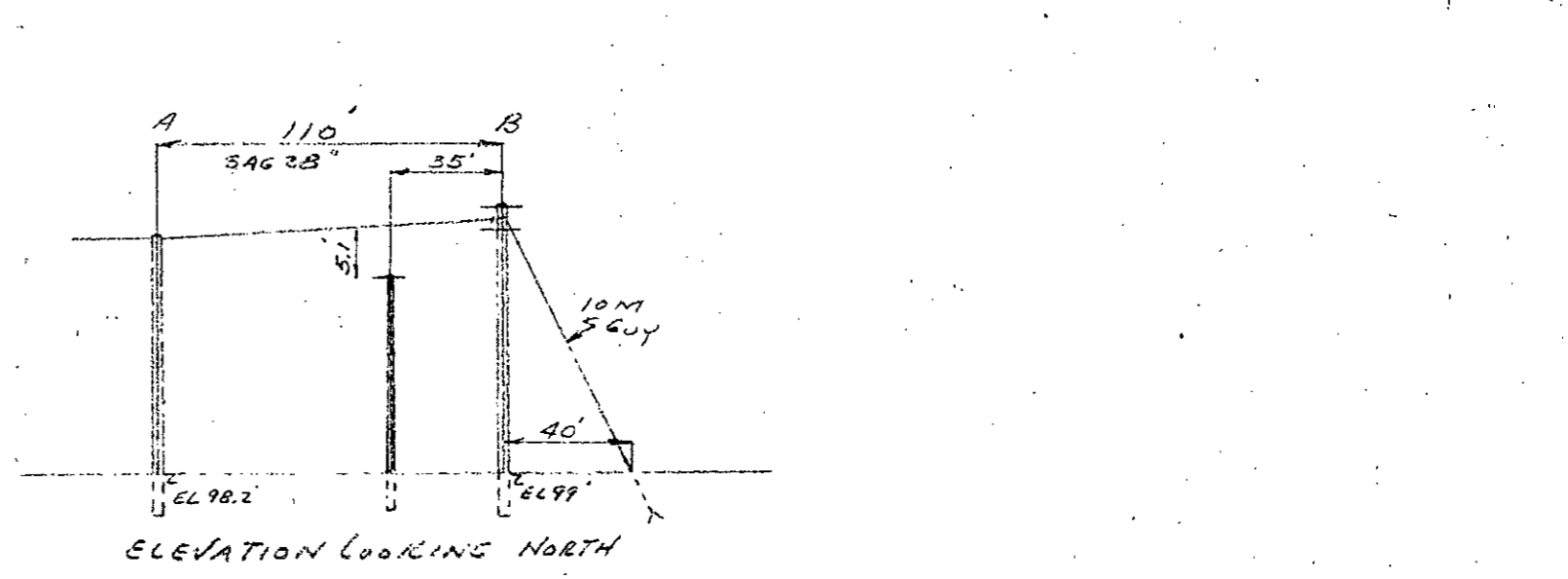
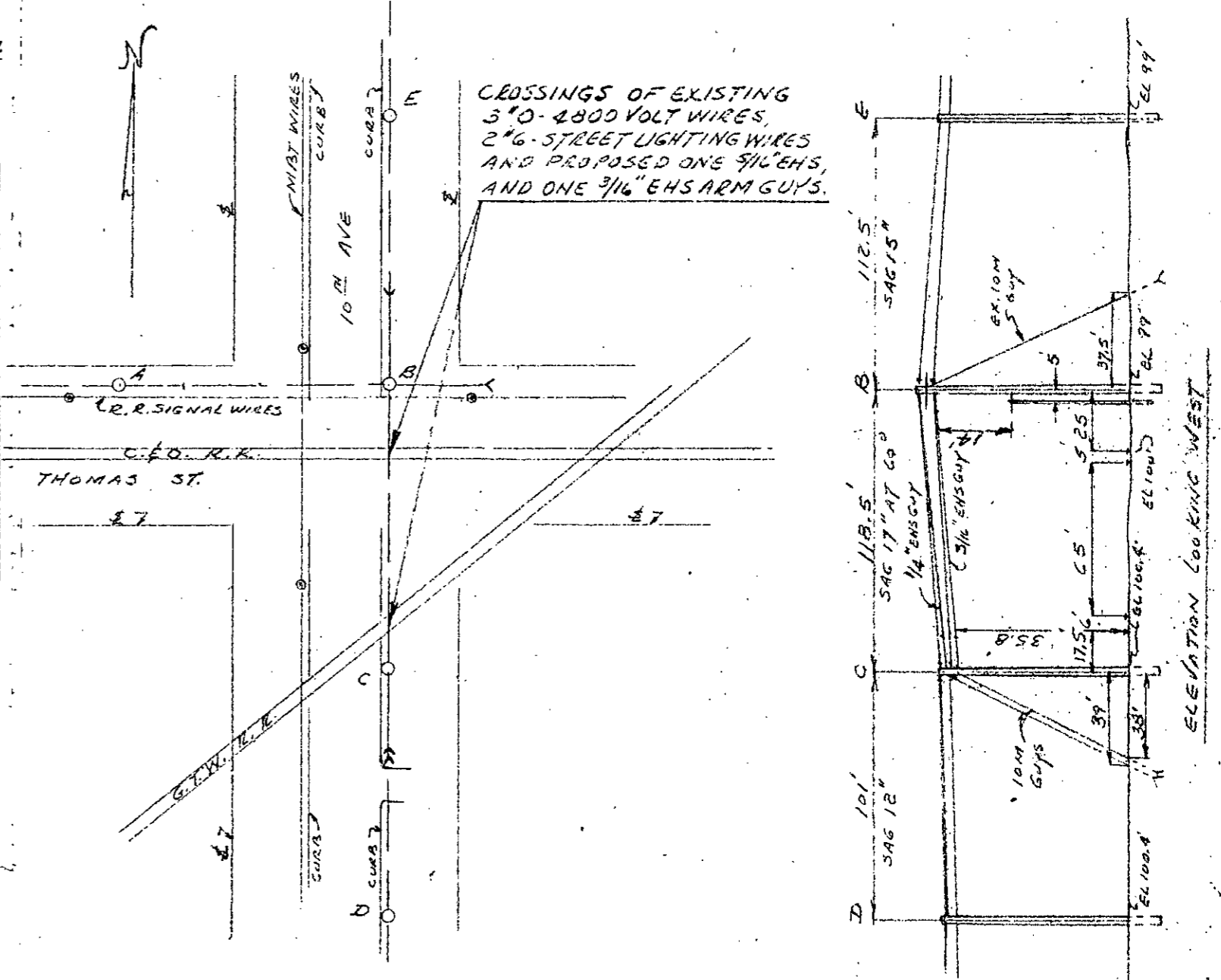
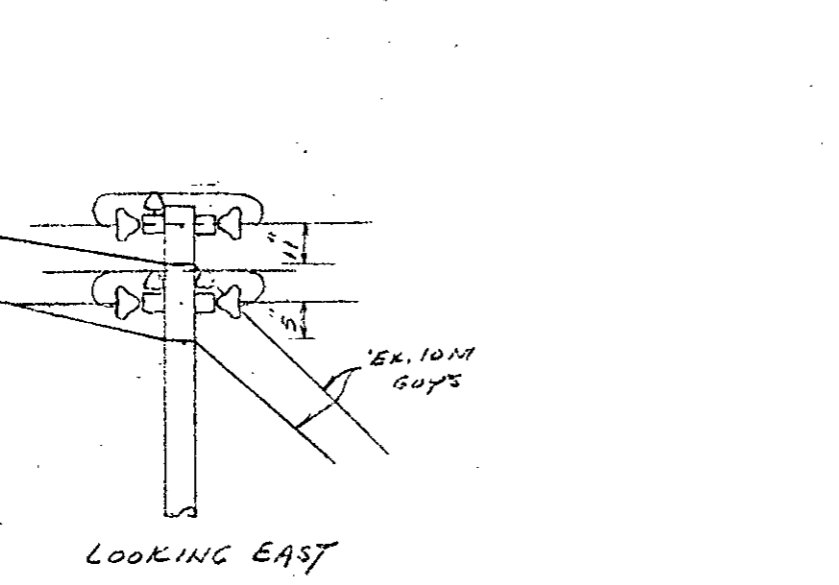
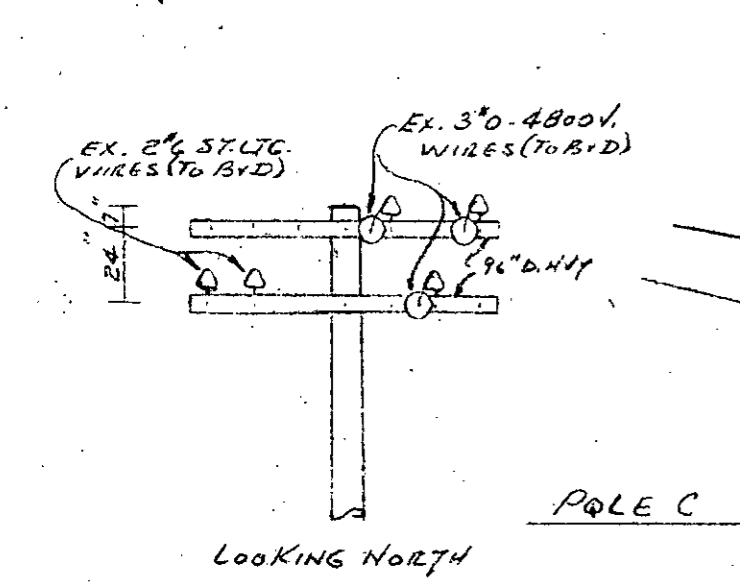
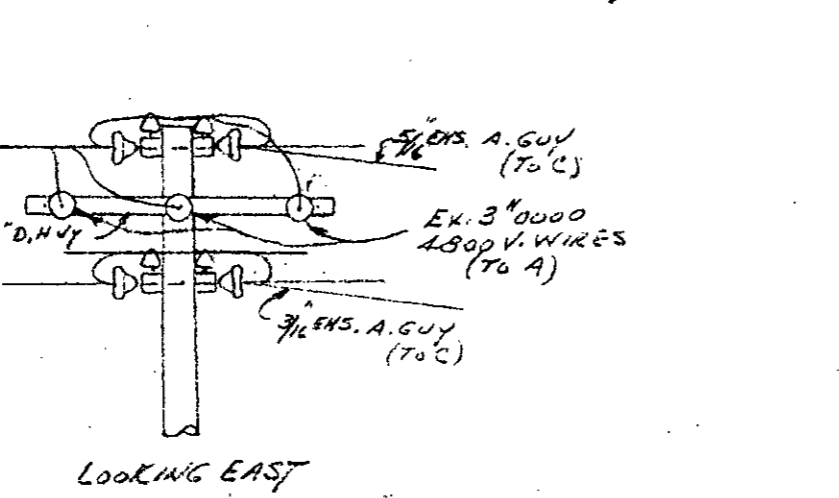
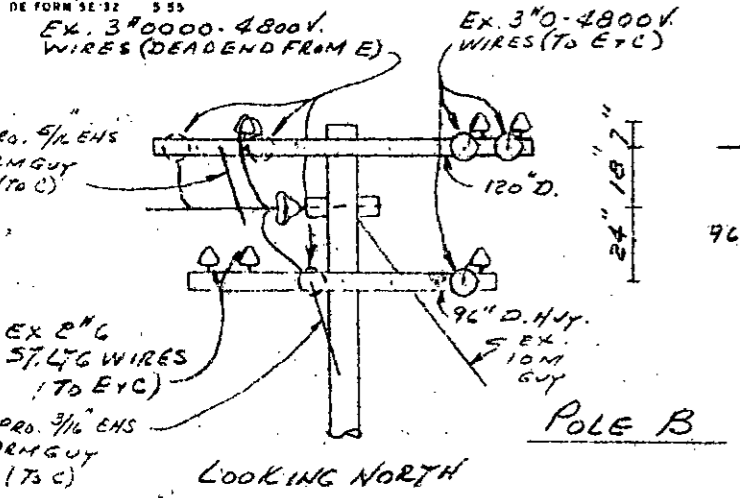

RECORDED RIGHT OF WAY NO. 34636  
p156