

THE DETROIT EDISON COMPANY

2000 SECOND AVENUE
DETROIT 26, MICHIGAN

February 28, 1966

Michigan Public Service Commission
Lansing 13, Michigan

Gentlemen:

The Detroit Edison Company, Detroit, Michigan, hereby makes application for authority to string the following wires over the tracks of the **Grand Trunk Western Railroad in the City of Port Huron, NE 1/4 of Section 3, Port Huron Township, T-6N, R-17E, St. Clair County, Michigan.**

Span B-C

Three #0 B-4800 volt wires, two #6 TWSP street lighting wires and one 1/2" steel guy wire over the tracks of the ~~CTRR~~ located in Poplar Street at a point approximately 200' north of the centerline of Thomas Street.

MICHIGAN PUBLIC SERVICE COMM.	
PUBLIC UTILITIES DIVISION	
Tel. _____	Gas _____
Elec. _____	R & S _____
MAR 1 1966	
Adm. _____	File _____

The proposed wire crossing will be constructed in accordance with specifications of the Michigan Public Service Commission and the construction standards of The Detroit Edison Company, approved by the Michigan Public Service Commission on July 19, 1939, File ED 2-9.01.

- Enclosed is a waiver of hearing granted by the Railroad Company.
- Waiver of hearing by the Railroad Company is covered by blanket waiver.
- This application covers reconstruction of existing crossing and will cancel and supersede wire crossing permit No. **ED-2-8-4041** dated **8-27-56**.
- This is a new crossing.

Reference number of construction drawing is **RX-713B**.

Yours very truly,

I. W. Gamble

I. W. Gamble
Supervisor of Rights of Way
Properties and Rights of Way Dept.

Permit No. ED2-8-5752
Date 3-2-66
By *J. M. Hoppe*

Check in circle indicates statement applicable.

RECORDED RIGHT OF WAY NO. 34636 70155



Grand Trunk Western Railroad Co

Battle Creek, Mich.
March 18, 1966
File: 60-35

Mr. I. W. Gamble
Supvr. of Rights of Way
The Detroit Edison Co.
2000 Second Ave.
Detroit, Michigan 48226

Dear Sir:

Your letter of Feb. 28, 1966, with attached plan RX-713B, applying for a standard waiver of hearing before the Michigan Public Service Commission for a wire crossing permit over our track in Poplar St. at a point approximately 155 ft. north of the centerline of Thomas St.

We have no objections to the above described crossing. No license will be required and you may use this letter as waiver of hearing before the Commission.

Very truly yours,

waiver not needed

I. A. Graham
I. A. Graham
Division Engineer

CLJ:

RECORDED RIGHT OF WAY NO.

34636

p/155

THE DETROIT EDISON COMPANY

2000 SECOND AVENUE
DETROIT 26, MICHIGAN

February 28, 1966

Michigan Public Service Commission
Lansing 13, Michigan

Gentlemen:

The Detroit Edison Company, Detroit, Michigan, hereby makes application for authority to string the following wires over the tracks of the **Grand Trunk Western Railroad in the City of Port Huron, NE 1/4 of Section 3, Port Huron Township, T-6N, R-17E, St. Clair County, Michigan.**

Span B-F

One 5/16" extra heavy strength pole guy over the tracks of the **GTWR** located in Poplar at a point approximately 155' north of the centerline of Thomas Street.

MICHIGAN PUBLIC SERVICE COMM.
UTILITY DIVISION

Tel. _____ Gas _____
Elec. _____ R & S _____

MAR 1 1966

Adm. _____
File _____

The proposed wire crossing will be constructed in accordance with specifications of the Michigan Public Service Commission and the construction standards of The Detroit Edison Company, approved by the Michigan Public Service Commission on July 19, 1939, File ED 2-9.01.

- Enclosed is a waiver of hearing granted by the Railroad Company.
- Waiver of hearing by the Railroad Company is covered by blanket waiver.
- This application covers reconstruction of existing crossing and will cancel and supersede wire crossing permit No. **ED-2-8-4042** dated **8-27-56**.
- This is a new crossing.

Reference number of construction drawing is **RX- 713B**.

Yours very truly,

I. W. Gamble

I. W. Gamble
Supervisor of Rights of Way
Properties and Rights of Way Dept.

Permit No. ED2-8-5751
Date 3-2-66
By *J. M. Hoppe*

Check in circle indicates statement applicable.

RECORDED RIGHT OF WAY NO.

34636 p/155

THE DETROIT EDISON COMPANY

2000 SECOND AVENUE
DETROIT 26, MICHIGAN

September 1, 1966



Permit No. ED 2-8-5752

Michigan Public Service Commission
Lansing 13, Michigan

Gentlemen:

I, PEARL I. HARDWICK - LINE DESIGN SUPERVISOR -
of The Detroit Edison Company, Detroit, Michigan, hereby certify that the
wire crossing, covered by Wire Crossing Permit No. ED 2-8-5752,
issued 3-2-66, has been constructed in accordance with
specifications of the Michigan Public Service Commission and construction
standards of The Detroit Edison Company, approved by Michigan Public Service
Commission on July 19, 1939, file ED 2-9.01, and that this crossing will be
maintained as provided in such specifications and construction standards.

Yours very truly,

P. I. Hardwick

RX No. 713B

Location City of Port Huron

Railroad Grand Trunk Western

Subscribed and sworn to before me this

1st day of September, 19 66

Lyman G. Hedden

Lyman G. Hedden
Notary Public, Oakland
County, Michigan.

My Commission expires October 15, 1966

34636
70155
See Also:
RECORDED RIGHT OF WAY NO. 9064-1303

THE DETROIT EDISON COMPANY

2000 SECOND AVENUE
DETROIT, MICHIGAN 48226

TO:

February 28, 1966

Mr. I. A. Graham, Division Engineer
Grand Trunk Western Railroad Company
Battle Creek, Michigan

Proposed Overhead Wire Crossing: One 5/16" extra heavy strength pole guy Span B-F

Specific Location **In Poplar Street at a point approximately 155 feet North of the center line of Thomas Street.**

R. R. Valuation Station _____ R. R. Mile Post _____

City/Village ~~Port Huron~~ **Port Huron** Township **Port Huron, NE 1/4 Section 3**

County **St. Clair** Detroit Edison Plan Attached **RX-713B**

This is a New Crossing _____ This is a Reconstruction of Existing Crossing

Previous Agreement Information (if any) Date _____ (R. R. Plan) _____

Blanket Waiver of Hearing Covers Waiver of Hearing Requested _____

(Waiver of Hearing to be mailed to applicant listed below)

All construction will be done in accordance with the rules and regulations of the Michigan Public Service Commission.

I. W. Gamble

**I. W. Gamble, Supervisor of Rights of Way
Properties and Rights of Way Department**

PROPOSED LINE CROSSING OVER GRAND TRUNK WESTERN RAILROAD CROSSING PERMIT NUMBER ED 2-B-4041
 IN POPLAR ST. 155' & 200' N. OF THOMAS ST. ED 2-B-4042

RX 713 B
 ED 2-B-4041
 ED 2-B-4042

CITY OF PORT HURON

SECTION 3 NE 1/4 TOWNSHIP PORT HURON (8-1) T 6N R 17E COUNTY ST. CLAIR

NOTES	CONDUCTORS				POLES			
	NUMBER	SIZE	KIND	VOLTAGE	LOCATION	LENGTH	CLASS	TYPE
MATERIALS SHALL BE AS NOTED IN THE DETROIT EDISON COMPANY'S GENERAL SPECIFICATIONS FOR OVERHEAD LINE CONSTRUCTION AT RAILROAD CROSSINGS DATED MARCH 1955. ACTUAL FIELD DIMENSIONS MAY VARY SOMEWHAT FROM THOSE SHOWN BUT THE REQUIREMENTS OF ORDER NO. 1679 OF MICHIGAN PUBLIC SERVICE COMMISSION AS REVISED JAN. 1, 1944, WILL BE COMPLIED WITH. MINIMUM CLEARANCES NEAREST POLE TO RAIL: SIDING 7 FT, MAIN LINE 12 FT WIRES OVER TRACKS: 0-750 VOLTS 27 FT, 750-15,000 VOLTS 28 FT, 15,000-50,000 VOLTS 30 FT WIRES OVER R R SIGNAL: 0-750 VOLTS 2 FT, 750-8,700 VOLTS 4 FT, 8,700-50,000 VOLTS 6 FT	1	5/16"	EHS	GUY WIRE	A	45	4	WOOD
	2	6	TBWP	ST. LGT.	B	45	3	"
	3	0	B	4800	C	40	3	"
	1	1/4"	STEEL	GUY	D	40	3	"
					E	40	3	"
					F	40	3	"
					G	40	3	"
					E	50	4	"

REV'D H.G.G. PLANNING & PROJECT
 DESIGNED BY F.W. BOND JR. ENGINEERING DEPT. DATE 2-12-66
 ESTIMATOR R. SMITH OVERHEAD LINES DEPT. PORT HURON

EXISTING CROSSING OF 2" 6 TBWP STREET LIGHT WIRES AND ONE 1/4" GUY WIRE AND PROPOSED REPLACING OF EX 3" 6 TBWP 4800 V. WIRES WITH 3" 0B.

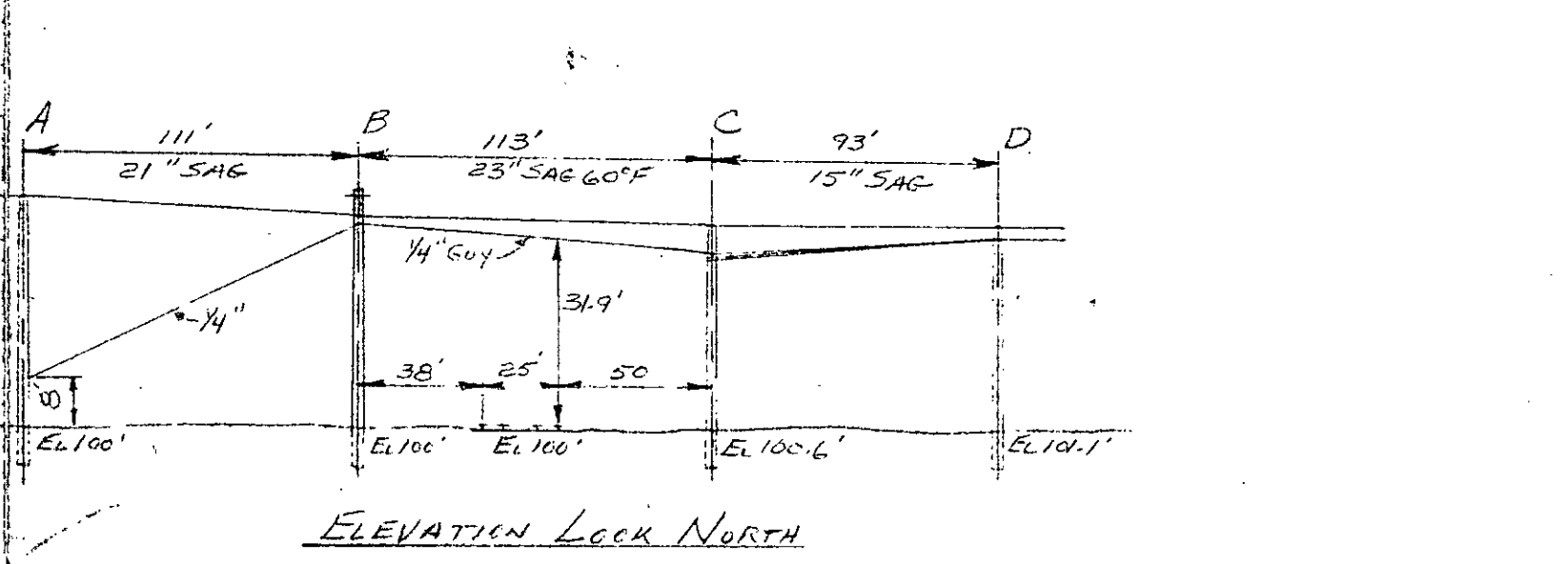
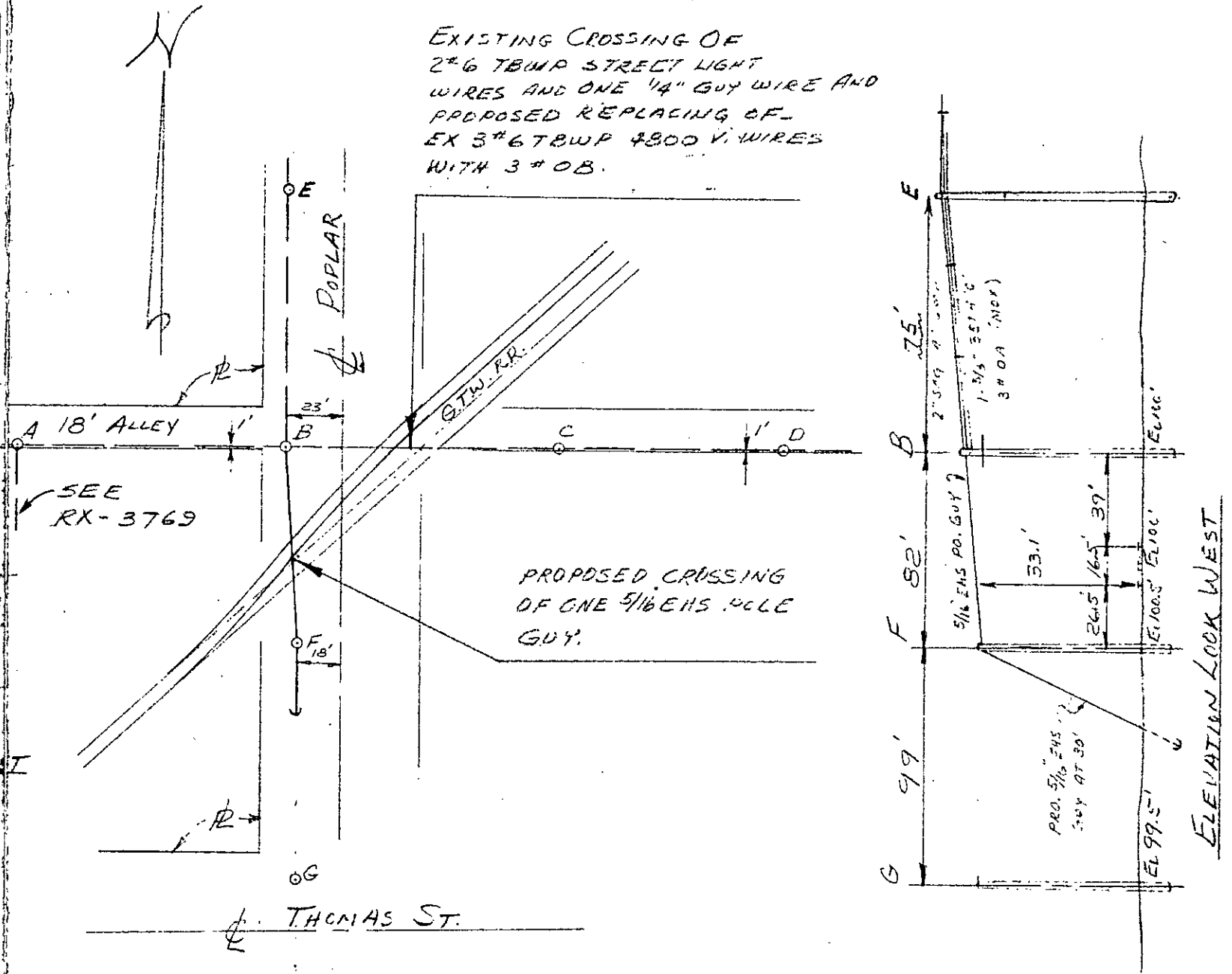
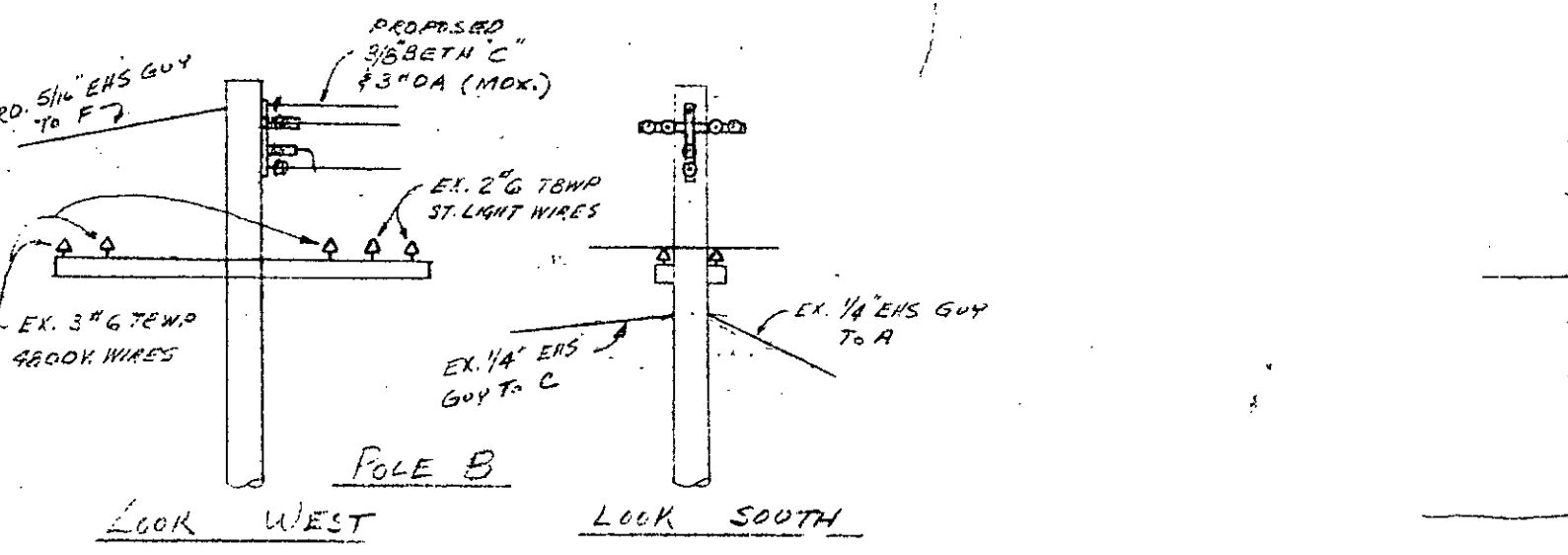
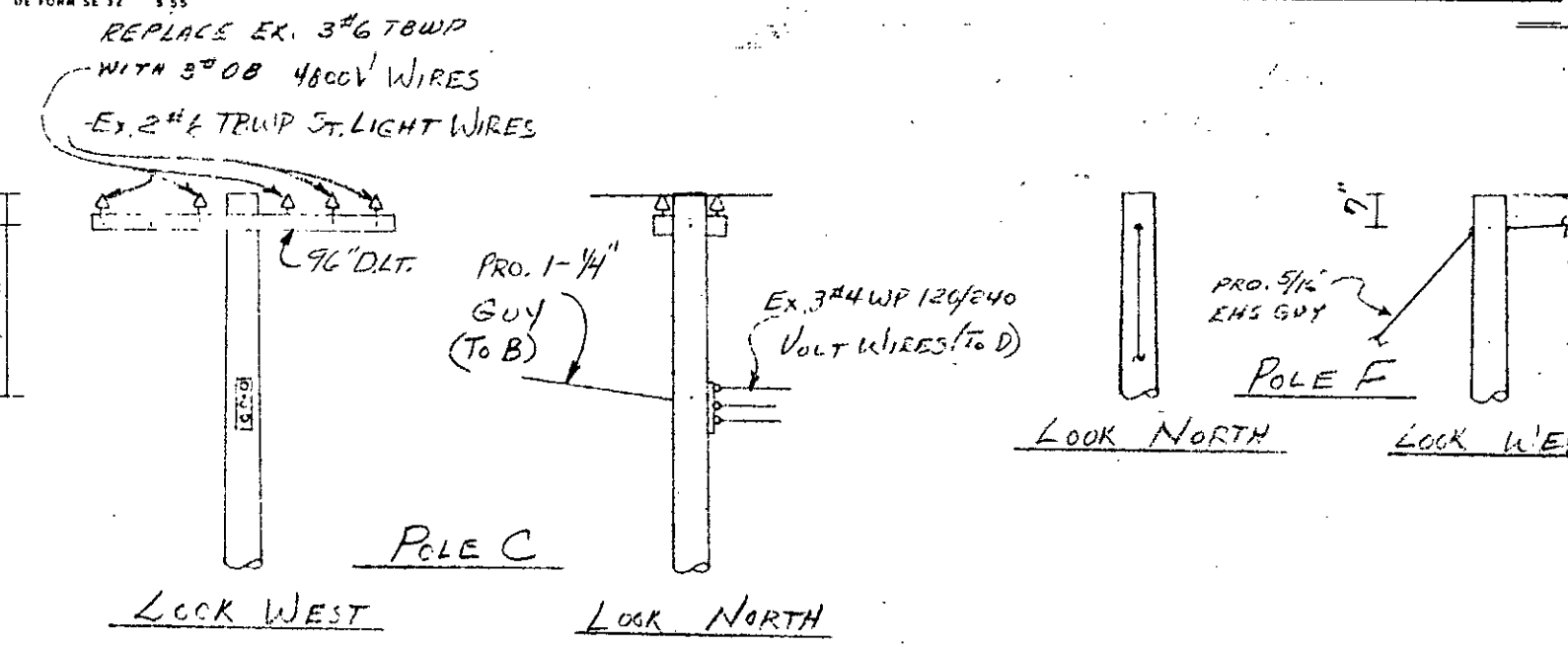

W.W.S

RECORDED RIGHT OF WAY NO. 34636
p155



Grand Trunk Western Railroad Co

Battle Creek, Mich.
March 18, 1966
File: 60-35

Mr. I. W. Gamble
Supvr. of Rights of Way
The Detroit Edison Co.
2000 Second Ave.
Detroit, Michigan 48226

Dear Sir:

Your letter of Feb. 28, 1966, with attached plan ⁷¹³⁸ ~~RX-173B~~,
applying for a standard waiver of hearing before the
Michigan Public Service Commission for a wire crossing
permit over our track in Poplar St. at a point approximately
200 ft. north of the centerline of Thomas St.

We have no objections to the above described crossing. No
license will be required and you may use this letter as
waiver of hearing before the Commission.

Very truly yours,

I. A. Graham
I. A. Graham
Division Engineer

CLJ:

waiver not needed

RECORDED RIGHT OF WAY NO.

34636
p155

THE DETROIT EDISON COMPANY

2000 SECOND AVENUE
DETROIT, MICHIGAN 48226

TO:

February 28, 1966

Mr. I. A. Graham, Division Engineer
Grand Trunk Western Railroad Company
Battle Creek, Michigan

Proposed Overhead Wire Crossing: Three #0 B-4800 volt wires, two #6 TBWP street lighting wires and one 1/4" steel guy wire.
Span B-C

Specific Location In Poplar Street at a point approximately 200 feet North of the center line of Thomas Street.

R. R. Valuation Station _____ R. R. Mile Post _____

City/Village ~~Marquette~~ Port Huron Township Port Huron NE 1/4 Section 3

County St. Clair Detroit Edison Plan Attached RY-713B

This is a New Crossing _____ This is a Reconstruction of Existing Crossing X

Previous Agreement Information (if any) Date _____ (R. R. Plan) _____

Blanket Waiver of Hearing Covers X Waiver of Hearing Requested _____

(Waiver of Hearing to be mailed to applicant listed below)

All construction will be done in accordance with the rules and regulations of the Michigan Public Service Commission.

I. W. Gamble

I. W. Gamble, Supervisor of Rights of Way
Properties and Rights of Way Department

WWS/jft

RECORDED IN THE OFFICE OF THE CITY CLERK
34636 p/155