

Hinks

MAY 25 '37

Form 4-a-7-22-36-10M

STATE OF MICHIGAN

Office of the Michigan Public Utilities Commission, } ss.



I, **Albert A. Wagner**, Secretary of the Michigan Public Utilities Commission,

Do Hereby Certify, That I have compared the annexed copy of **Permit ED2-8-15 (Revision)**

4211

with the original

recorded in **File ED2-8-15**

and that it is a true and correct transcript therefrom, and of the whole of such original.

In Testimony Whereof, I have hereunto set my hand and affixed

the seal of the Commission, at Lansing, this **19th**

day of **May** in the year of our Lord

. one thousand nine hundred **thirty-seven**

Albert A. Wagner
Secretary Michigan Public Utilities Commission

RECORDED REPORT OF WAY NO.

34636
P105

4211

STATE OF MICHIGAN
BEFORE MICHIGAN PUBLIC UTILITIES COMMISSION

Standard Railroad Wire-Crossing Permit No. ED2-8-15 (revision)

In Re Application of **Detroit Edison Company (Detroit)**

Pursuant to Act No. 171 of the Session Laws of 1893, as amended, application having been made to Michigan Public Utilities Commission by said

Detroit Edison Company
for permission to string wires across the tracks of the
Grand Trunk Western Railroad

and said **Detroit Edison Company**

having conformed to the Commission's rules governing the filing of notices and issuing of permits for the construction of electrical lines and said railroad company having waived the right of notice and hearing provided for in said act

THEREFORE, It is ordered that said

Detroit Edison Company

be permitted to string the following described wires across the tracks of said railroad at the following described place:

In City of Mt. Clemens,)
Macomb County,)
Michigan:--)

In Mary Avenue, 500 ft. northeast
of Cass Avenue or 100 ft. north
of Mile Post 22, with:-

Add 1 - 6M guy wire in span B - E

as indicated on the attached plans, when, as and if approved.

At the point of crossing said wires shall be constructed in accordance with this Commission's rules and regulations.

Given under our hands and the Official Seal of this
Commission at the City of Lansing, State of Mich-
igan, this 19th day of May
A. D. 19 37

RECORDED RIGHT OF WAY

MICHIGAN PUBLIC UTILITIES COMMISSION

By

Paul H. Todd

Chairman,

Philip Elliott

Commissioner,

Glenwood C. Fuller

Commissioner,

William M. Smith

Commissioner,

Countersigned

Albert A. Wagner

Secretary

Howell Van Auken

Commissioner.

no. 34636
p105

RX 534-A

STATE OF MICHIGAN

Office of the Michigan Public Utilities Commission, } ss.

I, J. Carl Sheil, Secretary of the Michigan Public Utilities Commission,

Do Hereby Certify, That I have compared the annexed copy of Permit No. U-3530

2272

2272

with the original permit

~~reproduced by~~

and that it is a true and correct transcript therefrom, and of the whole of such original.

In Testimony Whereof, I have hereunto set my hand and affixed

the seal of the Commission, at Lansing, this 18th

day of March in the year of our Lord

one thousand nine hundred twenty-seven

J. Carl Sheil
Secretary, Michigan Public Utilities Commission.

RECORDED RIGHT OF WAY NO.

34686
PDS

STATE OF MICHIGAN
BEFORE MICHIGAN PUBLIC UTILITIES COMMISSION

Standard Railroad Wire-Crossing Permit No.....U-3530

In Re Application of Detroit Edison Company (Detroit)

Pursuant to Act No. 171 of the Session Laws of 1898, as amended, application having been made to Michigan Public Utilities Commission by said Detroit Edison Company

for permission to string wires across the tracks of the Grand Trunk Railway System

and said Detroit Edison Company

having conformed to the Commission's rules governing the filing of notices and issuing of permits for the construction of electrical lines and said rail way company having waived the right of notice and hearing provided for in said act

THEREFORE, It is ordered that said Detroit Edison Company

be permitted to string the following described wires across the tracks of said railroad at the following described place:

City of Mt. Clemens,)	In Mary Avenue, 500 ft. NE of Cass
Macomb County,)	Ave. with:
Michigan:-)	
	"	3 - #6 copper wires, 240 volts, 3-phase;
	"	3 - #8 " " ,120/240 " ,single-phase.

as indicated on the attached plans, when, as and if approved.

At the point of crossing said wires shall be constructed in accordance with this Commission's rules and regulations.

Given under our hands and the Official Seal of this Commission at the City of Lansing, State of Michigan, this 18th day of March A. D. 19 27.

MICHIGAN PUBLIC UTILITIES COMMISSION
By

SHERMAN T. HANDY
Chairman,

SAMUEL ODELL
Commissioner,

SAMUEL D. PEPPER
Commissioner,

ROLPH DUFF
Commissioner,

SIDNEY E. DOYLE
Commissioner.

MEW

RECORDED RIGHT OF WAY NO.

34636
905

COMMISSIONER
COMMISSIONER
COMMISSIONER
COMMISSIONER

MICHIGAN PUBLIC UTILITIES COMMISSION

IN RE: ...
...
...
...
...

Wherefore it is requested that the Commission order the respondent to pay the costs of this proceeding and to grant the respondent's motion for summary judgment.

Very truly yours,
[Signature]

W. L. ...
...
...
...
...

to be subject to the order of the Commission and to the order of the respondent to pay the costs of this proceeding and to grant the respondent's motion for summary judgment.

Very truly yours,
[Signature]

BEFORE MICHIGAN PUBLIC UTILITIES COMMISSION

STATE OF MICHIGAN

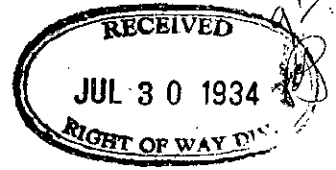

STATE OF MICHIGAN

Office of the Michigan Public Utilities Commission, } ss.

I, **Peter Fagan**, Secretary of the Michigan Public Utilities Commission

Do Hereby Certify, That I have compared the annexed copy of **Permit No. ED 2-8-15**

with the original permit

recorded in **File No. ED 2-8-15**

and that it is a true and correct transcript therefrom, and of the whole of such original.

In Testimony Whereof, I have hereunto set my hand and affixed

the seal of the Commission, at Lansing, this **26th**

day of **July** in the year of our Lord

one thousand nine hundred **thirty-four.**

Secretary, Michigan Public Utilities Commission

RECORDED RIGHT OF WAY NO.

34636
P105

3727

3727

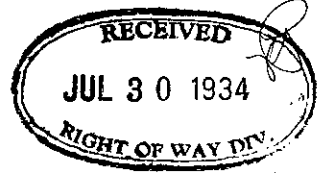

STATE OF MICHIGAN
BEFORE MICHIGAN PUBLIC UTILITIES COMMISSION

Standard Railroad Wire-Crossing Permit No. ED-2-8-15

In Re Application of **Detroit Edison Company (Detroit)**

Pursuant to Act No. 171 of the Session Laws of 1893, as amended, application having been made to Michigan Public Utilities Commission by said **Detroit Edison Company**

for permission to string wires across the tracks of the **Grand Trunk Western Railroad Co.**

and said **Detroit Edison Company**

having conformed to the Commission's rules governing the filing of notices and issuing of permits for the construction of electrical lines and said rail **road** company having waived the right of notice and hearing provided for in said act

THEREFORE, It is ordered that said **Detroit Edison Company**

be permitted to string the following described wires across the tracks of said railroad at the following described place:

In City of Mount Clemens } In Mary Avenue, 500 ft. NE of Cass Avenue
Macomb County, } or 100 ft North of Mile Post 22, with,
Michigan:-- } 4 - #2 copper wires, 120/240 volts
single and three-phase

as indicated on the attached plans, when, as and if approved.

At the point of crossing said wires shall be constructed in accordance with this Commission's rules and regulations.

Given under our hands and the Official Seal of this Commission at the City of Lansing, State of Michigan, this **26th** day of **July** A. D. 19 **34**

MICHIGAN PUBLIC UTILITIES COMMISSION
By

James B. Balch
Chairman,

Robert H. Dunn
Commissioner,

Frank J. Sawyer
Commissioner,

Norman M. Snider
Commissioner,

Harold J. Waples
Commissioner.

Countersigned

Peter Fagan
Secretary

RECORDED RIGHT OF WAY NO.

34636
p 105

THE UNIVERSITY OF CHICAGO LIBRARY

1000 S. EAST ASIAN BLDG.

Faint, illegible text, possibly bleed-through from the reverse side of the page.

L



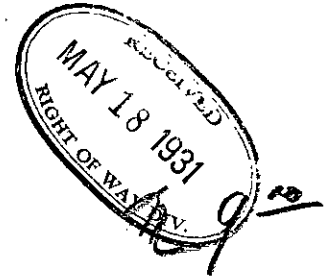

STATE OF MICHIGAN
Office of the Michigan Public Utilities Commission, } ss.

I, **J. Carl Sheil**, Secretary of the Michigan Public Utilities Commission

Do Hereby Certify, That I have compared the annexed copy of **Permit No. U-7838**

3425

wih the original permit

recorded in

and that it is a true and correct transcript therefrom, and of the whole of such original.

3425

In Testimony Whereof, I have hereunto set my hand and affixed
the seal of the Commission, at Lansing, this **16th**
day of **May** in the year of our Lord
one thousand nine hundred **thirty-one**

Secretary, Michigan Public Utilities Commission

RECORDED RIGHT OF WAY NO.

34636
P105

MEW

STATE OF MICHIGAN
BEFORE MICHIGAN PUBLIC UTILITIES COMMISSION

Standard Railroad Wire-Crossing Permit No. U-7838

In Re Application of Detroit Edison Company (Detroit)

Pursuant to Act No. 171 of the Session Laws of 1893, as amended, application having been made to Michigan Public Utilities Commission by said Detroit Edison Company

for permission to string wires across the tracks of the Grand Trunk Western Railroad Co.

and said Detroit Edison Company

having conformed to the Commission's rules governing the filing of notices and issuing of permits for the construction of electrical lines and said rail ~~road~~ company having waived the right of notice and hearing provided for in said act

THEREFORE, It is ordered that said Detroit Edison Company

be permitted to string the following described wires across the tracks of said railroad at the following described place:

In City of Mount Clemens,) In Mary Avenue, approximately
Macomb County, Mich.:) 500 ft. N.E. of Cass Avenue, with:

3 - #2 copper wires, 120/240 volts,
single-phase and - 3 - #2 copper
wires, 240 volts, three-phase.

as indicated on the attached plans, when, as and if approved.

At the point of crossing said wires shall be constructed in accordance with this Commission's rules and regulations.

Given under our hands and the Official Seal of this Commission, at the City of Lansing, State of Michigan, this 10th day of May A. D. 1915.

MICHIGAN PUBLIC UTILITIES COMMISSION
By

ALVA M. CUMMINS

Chairman,

SAMUEL ODELL

Commissioner,

JAMES BICE

Commissioner,

ROBERT H. DUNN

Commissioner,

RUSSELL A. GORMAN

Commissioner.

Countersigned

J. Carl Shell

Secretary

RECORDED RIGHT OF WAY NO.

34636
9/25

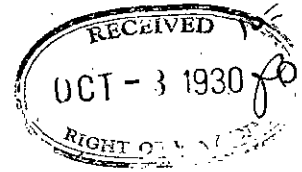

STATE OF MICHIGAN
Office of the Michigan Public Utilities Commission, } ss.

I, **J. Carl Sheil**, Secretary of the Michigan Public Utilities Commission

Do Hereby Certify, That I have compared the annexed copy of Permit No. **Up7258**

wih the original permit

recorded in

and that it is a true and correct transcript therefrom, and of the whole of such original.

In Testimony Whereof, I have hereunto set my hand and affixed
the seal of the Commission, at Lansing, this **1st**
day of **October** in the year of our Lord
one thousand nine hundred **thirty**

Secretary, Michigan Public Utilities Commission

3293

3293

RECORDED RIGHT OF WAY NO.

34636

P105

STATE OF MICHIGAN
BEFORE MICHIGAN PUBLIC UTILITIES COMMISSION

Standard Railroad Wire-Crossing Permit No. U-7258

In Re Application of **Detroit Edison Company (Detroit)**

Pursuant to Act No. 171 of the Session Laws of 1893, as amended, application having been made to Michigan Public Utilities Commission by said **Detroit Edison Company**

for permission to string wires across the tracks of the **Grand Trunk Railway System**

and said **Detroit Edison Company**

having conformed to the Commission's rules governing the filing of notices and issuing of permits for the construction of electrical lines and said rail ~~way~~ company having waived the right of notice and hearing provided for in said act

THEREFORE, It is ordered that said **Detroit Edison Company**

be permitted to string the following described wires across the tracks of said railroad at the following described place:

City of Mount Clemens,)
Macomb County,)
Michigan.)

In ~~May~~ Avenue, approximately 500 ft. N.E. of Cass Ave., with:

2 - #6 copper wires, 5000 volts, street-lighting.

as indicated on the attached plans, when, as and if approved.

At the point of crossing said wires shall be constructed in accordance with this Commission's rules and regulations.

Given under our hands and the Official Seal of this Commission at the City of Lansing, State of Michigan, this 1st day of October A. D. 19 30.

MICHIGAN PUBLIC UTILITIES COMMISSION
By

ROBERT H. DUNN

Chairman,

SAMUEL ODELL

Commissioner,

ALVA M. CUMMINS

Commissioner,

RUSSELL A. GORMAN

Commissioner,

JAMES BICE

Commissioner.

Countersigned

J. Carl Shell

Secretary

MEW

RECORDED RIGHT OF WAY NO.

34636
P 105

Handwritten text, possibly a date or reference number, oriented vertically on the left side of the page.

Handwritten text, possibly a name or title, oriented vertically on the left side of the page.



STATE OF MICHIGAN

Office of the Michigan Public Utilities Commission, } ss.

I, J. Carl Sheil, Secretary of the Michigan Public Utilities Commission,

Do Hereby Certify, That I have compared the annexed copy of permit No. U-5250

with the original permit

recorded in

and that it is a true and correct transcript therefrom, and of the whole of such original.

In Testimony Whereof, I have hereunto set my hand and affixed

the seal of the Commission, at Lansing, this 7th

day of January in the year of our Lord

one thousand nine hundred twenty-nine

J. Carl Sheil

Secretary, Michigan Public Utilities Commission.

MEW

RECORDED RIGHT OF WAY NO.

34636
P/05

2793

2793

STATE OF MICHIGAN
BEFORE MICHIGAN PUBLIC UTILITIES COMMISSION

Standard Railroad Wire-Crossing Permit No. U-5250

In Re Application of **Detroit Edison Company (Detroit)**

Pursuant to Act No. 171 of the Session Laws of 1898, as amended, application having been made to Michigan Public Utilities Commission by said **Detroit Edison Company**

for permission to string wires across the tracks of the **Grand Trunk Railway Company**

and said **Detroit Edison Company**

having conformed to the Commission's rules governing the filing of notices and issuing of permits for the construction of electrical lines and said rail way company having waived the right of notice and hearing provided for in said act

THEREFORE, It is ordered that said **Detroit Edison Company**

be permitted to string the following described wires across the tracks of said railroad at the following described place:

City of Mt. Clemens,
Macomb County,
Michigan: -

In Mary Avenue, 500 ft. NE of
Cass Ave. with:

3 - #6 copper wires, 240 volts, 3-phase;
3 - #6 " " ,120/240 " , single-
phase.

as indicated on the attached plans, when, as and if approved.

At the point of crossing said wires shall be constructed in accordance with this Commission's rules and regulations.

Given under our hands and the Official Seal of this Commission at the City of Lansing, State of Michigan, this **7th** day of **January** A. D. **1929**.

MICHIGAN PUBLIC UTILITIES COMMISSION
By

SIDNEY E. DOYLE

Chairman,

JAMES BICE

Commissioner,

BYRON P. HICKS

Commissioner,

ROBERT H. DUNN

Commissioner,

SAMUEL ODELL

Commissioner.

Countersigned

J. Carl Shoil

Secretary

RECORDED RIGHT OF WAY NO. 34636 P105

THE DETROIT EDISON CO.

PLAN SUBMITTED TO MICHIGAN PUBLIC UTILITIES COMMISSION
FOR
OVERHEAD LINE CROSSING

RX 5341

OVER GRAND TRUNK RY SIDING IN MARY STREET R R

CITY OF MT CLEMENS SECTION PC 541
CLINTON TOWNSHIP T 2N R 13E MACOMB COUNTY

CIRCUITS CONDUCTORS

NUMBER	VOLTAGE	CYCLES	PHASE	USE	WIRES	SIZE	KIND
(SPAN B-C) ONE	120/240	60	3	SERVICE	4	2	MH. TBWP SOLID COPPER
(SPAN B-E) ONE	5000	60	SERIES ST LTG		2	6	" " " "
ONE	120/240	60	3	SERVICE	4	2	" " " "

POLES

LOCATION	LENGTH	MATERIAL	CIRCUMFERENCE AT TOP	CIRCUMFERENCE AT GROUND	DEPTH OF SETTING	KIND OF SETTING
A-R-F	45'	IDAHO CEDAR	25"	45"	6'-6"	CLAY SOIL
2	45'	"	23"	43"	6'-6"	"
C-3	40'	"	25"	43"	6'	CONCRETE
1	30'	WESTERN CEDAR	27"	41"	6'	CONCRETE

NOTE
MATERIALS SHALL BE AS NOTED IN THE DETROIT EDISON COMPANY'S STANDARD SPECIFICATIONS FOR OVERHEAD LINE CONSTRUCTION AT RAILROAD CROSSINGS ISSUED DECEMBER 23, 1935.

PURPOSE OF LINE
REPLACING 3" 6-4800 VOLT WIRES EXISTING UNDER PERMIT ED-2-8-15 WITH 3" 2-4800 VOLT WIRES IN SPAN A-B AND ADDING ONE 6M GUY WIRE IN SPAN B-E.
DRAWN BY WSM, DATE 5-13-37 CHECKED BY WJ, DATE 5-13-37

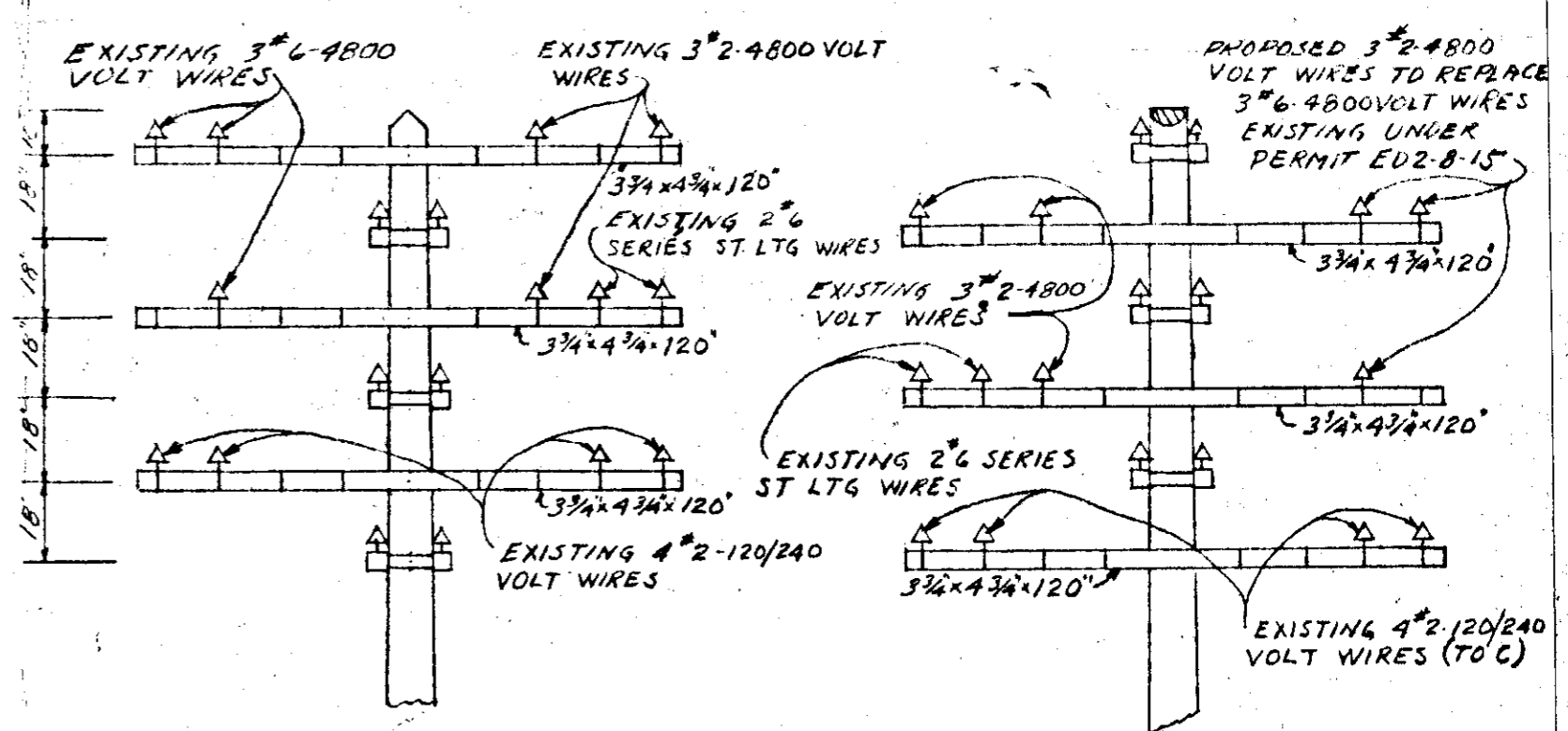
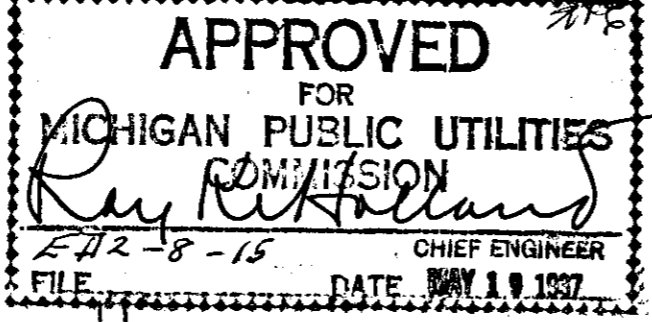

POLE B LOOKING NORTHEAST

POLE B LOOKING NORTHWEST

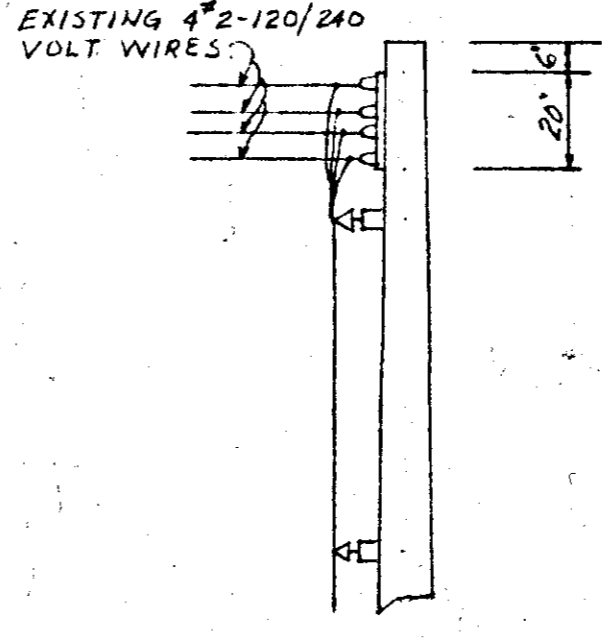

POLE C LOOKING NORTH

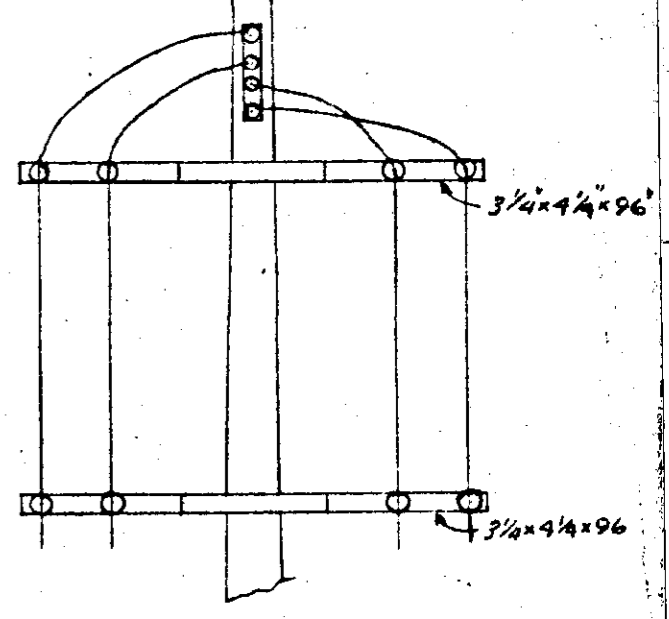

POLE C LOOKING EAST

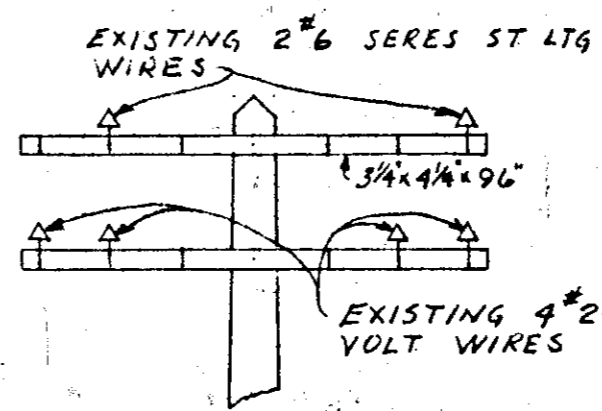

POLE F LOOKING NORTHEAST

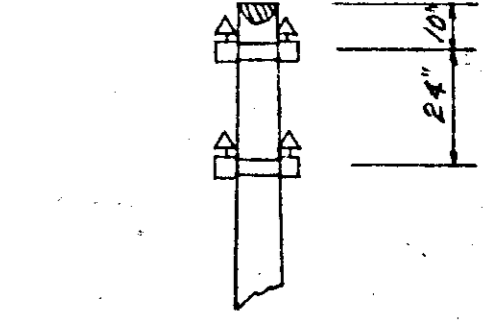

POLE F LOOKING NORTHWEST

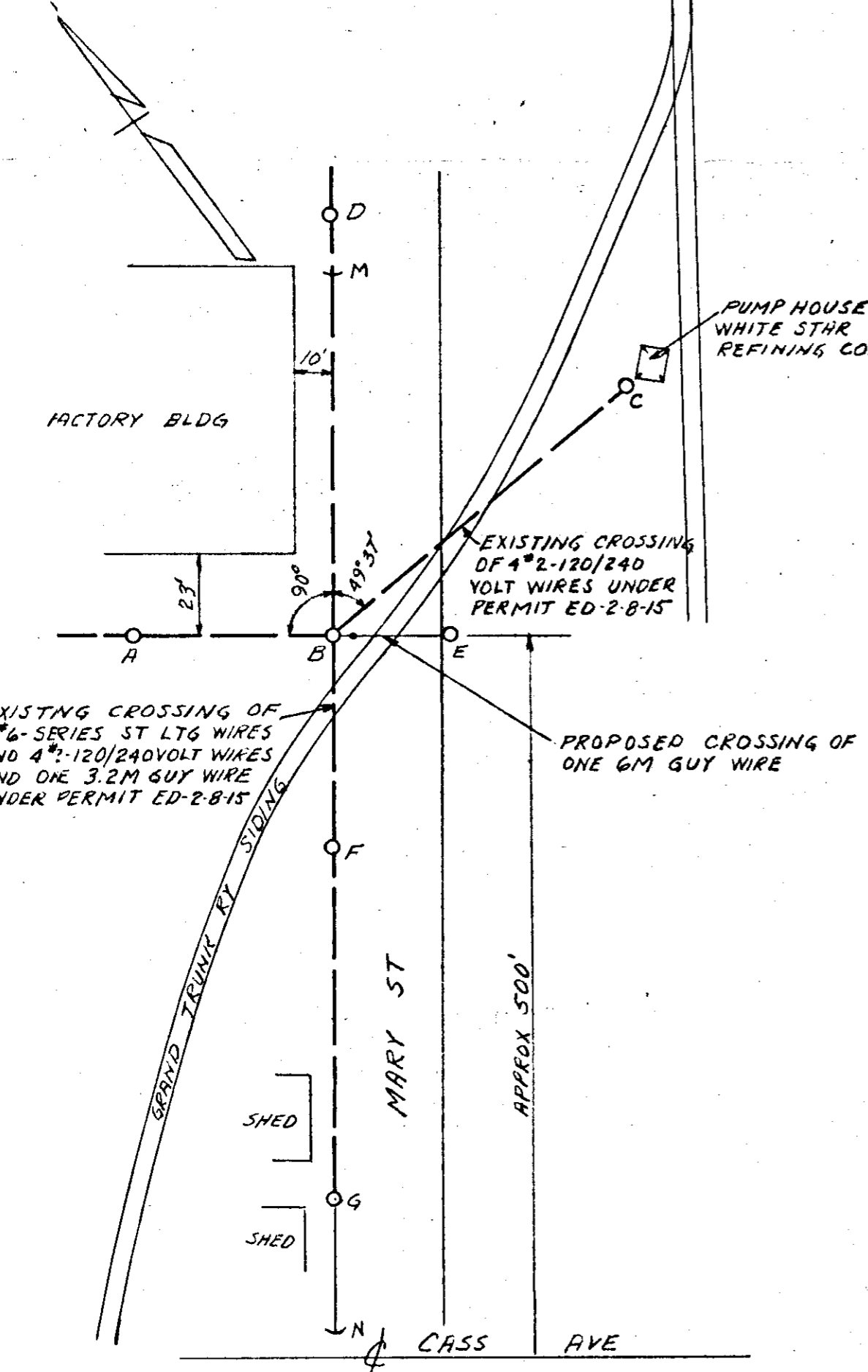

PLAN OF CROSSING

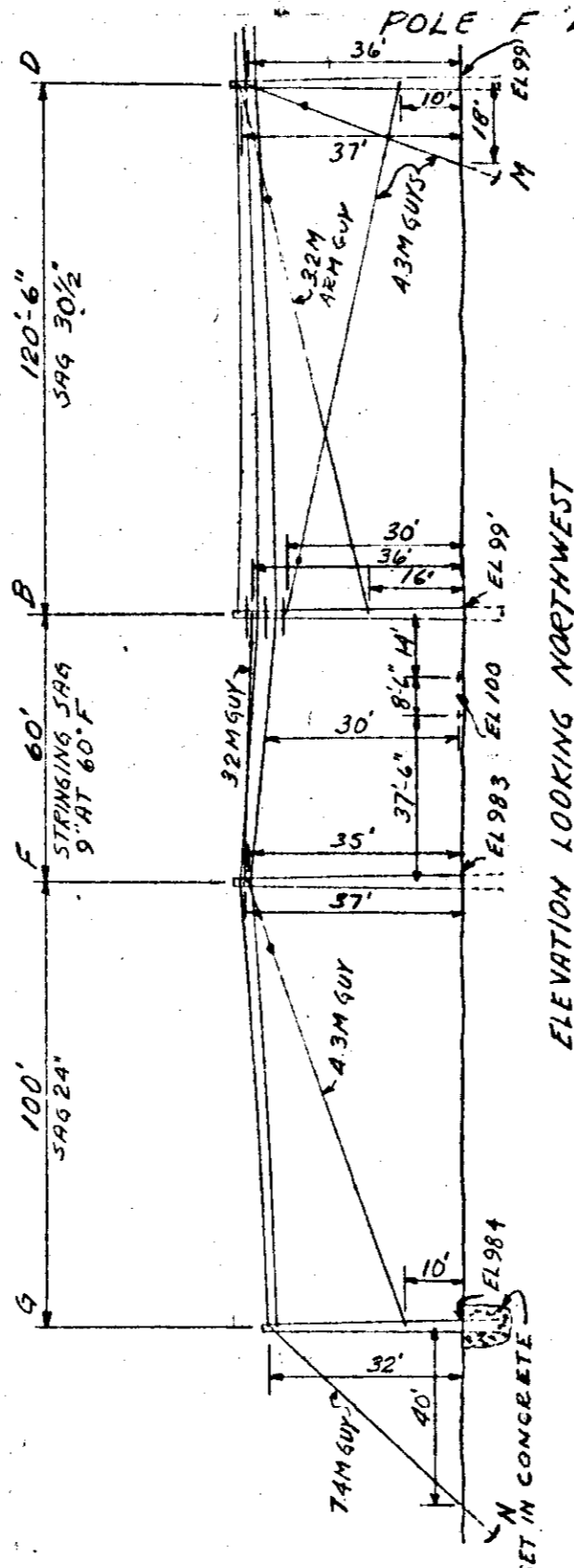

ELEVATION LOOKING NORTHWEST

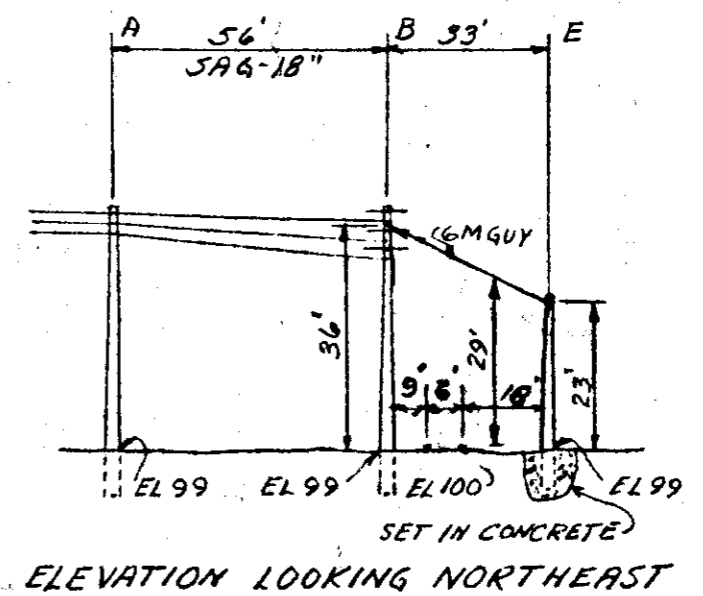

ELEVATION LOOKING NORTHEAST

RECORDED RIGHT OF WAY
R346105

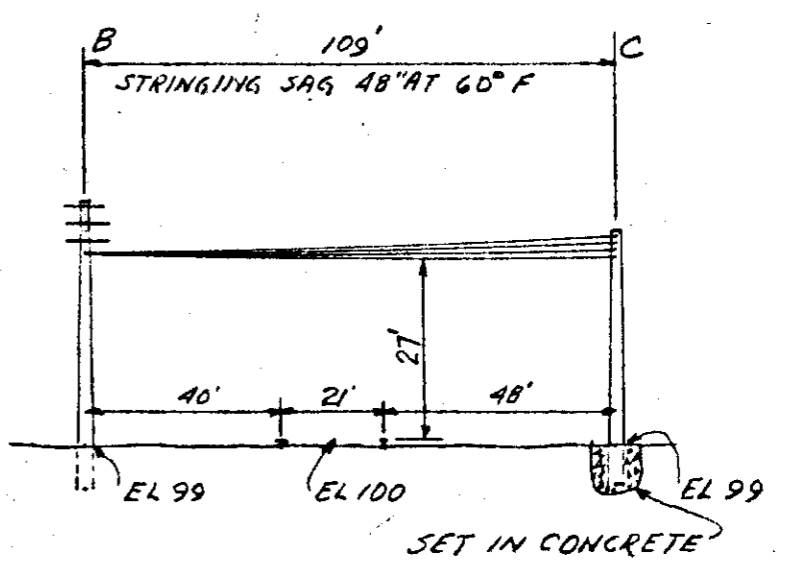

ELEVATION LOOKING NORTH

R34636
4

RECORDED RIGHT OF WAY NO. 34636
P105

R34636 P105

John P. Miller
12-11-73
John P. Miller
12-11-73
John P. Miller
12-11-73

RECORDED RIGHT OF WAY NO. 34636 P105