

RAILROAD RIGHT OF WAY

DOCUMENT(S) WILL BE SCANNED
AT A LATER TIME

RECORDED RIGHT OF WAY NO. R33814

REAL ESTATE AND RIGHTS OF WAY

RX 4329

RR Conrail

Date: August 11, 1987
To: Vicki C. Sullivan
Supervisor
Records Center
From: Brenda L. Golson
Railroads Coordination Specialist
Subject: Additional Papers to Records Center

Attached are papers related to the termination of the above railroad agreement, effective October 17, 1986.

Please incorporate in Records Center File No. 33814.

Tickle for six years after the cancellation date. At the end of this period, please return the file to Real Estate and Rights of Way for removal from the Railroad Computer Records. It will then be returned to the Records Center for destruction.

Approved: Thomas Wilson / Blg
Thomas Wilson
Real Estate Associate

/BLG

attachment

cc: C. VanParis

RECORDED RIGHT OF WAY NO.

33814

No. 866357

RECEIPT FOR CERTIFIED MAIL

NO INSURANCE COVERAGE PROVIDED—
NOT FOR INTERNATIONAL MAIL
(See Reverse)

SENT TO
CONSOLIDATED RAIL CORP.
STREET AND NO.
1528 WALNUT STREET-8TH FL.
P.O., STATE AND ZIP CODE
PHILADELPHIA, PA 19102

126

August 11, 1987

POSTAGE		\$
CONSULT POSTMASTER FOR FEES	CERTIFIED FEE	¢
	SPECIAL DELIVERY	¢
	RESTRICTED DELIVERY	¢
	OPTIONAL SERVICES	
	RETURN RECEIPT SERVICE	
	SHOW TO WHOM AND DATE DELIVERED	¢
SHOW TO WHOM, DATE, AND ADDRESS OF DELIVERY	¢	
SHOW TO WHOM AND DATE DELIVERED WITH RESTRICTED DELIVERY	¢	
SHOW TO WHOM, DATE AND ADDRESS OF DELIVERY WITH RESTRICTED DELIVERY	¢	
TOTAL POSTAGE AND FEES		\$

Wogan
Manager-Contracts
Consolidated Rail Corporation
1528 Walnut Street
Philadelphia, PA 19102

Termination of Railroad Agreement
File No. DE 326; Our File No. RX 4329-BT 9995

POSTMARK OR DATE
MR. C. E. WOGAN
GENERAL MANAGER-CONTRACTS

Wogan:

Herewith is notice of the termination of an overhead
agreement effective October 17, 1986. Detroit
Railroad Company has removed its equipment from your
property.

Location:

420 Feet North of 16 Mile Road, 2640 Feet West of Van
Dyke, SW 1/4, Section 21, Sterling Heights, Macomb
County, Michigan

Please cancel this agreement in your records. If you have
any questions, please call Brenda L. Golson, Railroads
Coordination Specialist, (313) 237-8316.

Sincerely,

Thomas Wilson /bf

Thomas Wilson
Real Estate Associate

RECORDED RIGHT OF WAY NO.

33814

/BLG

cc: Records Center
File No. 33814

CERTIFIED MAIL 866357
RETURN RECEIPT REQUESTED

PS Form 3800, Apr. 1976



2000 Second Avenue
Detroit, Michigan 48226
(313) 237-8000

August 11, 1987

Mr. C. E. Wogan
General Manager-Contracts
Consolidated Rail Corporation
1528 Walnut Street
Eighth Floor
Philadelphia, PA 19102

Re: Termination of Railroad Agreement
Your File No. DE 326; Our File No. RX 4329-BT 9995

Dear Mr. Wogan:

This letter is notice of the termination of an overhead railroad agreement effective October 17, 1986. Detroit Edison Company has removed its equipment from your property.

Location:

420 Feet North of 16 Mile Road, 2640 Feet West of Van Dyke, SW 1/4, Section 21, Sterling Heights, Macomb County, Michigan

Please cancel this agreement in your records. If you have any questions, please call Brenda L. Golson, Railroads Coordination Specialist, (313) 237-8316.

Sincerely,

Thomas Wilson
Real Estate Associate

/BLG

cc: Records Center
File No. 33814

CERTIFIED MAIL 866357
RETURN RECEIPT REQUESTED

RECORDED RIGHT OF WAY NO.

33814

Submit One (1) Copy for each Span to
Real Estate and Rights of Way Dept.

BT 9995
RC 33814

THE DETROIT EDISON COMPANY

RAILROAD CROSSING REMOVAL

RX 4329

Span 763'

M.P.S.C. Permit and Date ME-109-81 3-27-81

Railroad: Consolidated Rail Corp.

Location: S.W. 1/4, sec 21 Sterling Heights, Macomb Co. Michigan.

Reason: RX-4332 took its place

RECORDED RIGHT OF WAY NO. 33814

System Engineering Dept.

Date 10-17-86
By CLARK VAN PARI'S

DATA SHEET TO ACCOMPANY DRAWING RX -4329

Name of Company

The Detroit Edison Company

Name and Location of Crossing

Crossing of the Chestnut Sterling-(Logan), and the Northeast - Sterling (Logan) (Skylark) 120kV circuits over the Consolidated Rail Corp. approximately 420 feet north of 16 Mile Road, and approximately 2,640 feet west of Van Dyke Ave.

Located in the southwest $\frac{1}{4}$ of section 21, City of Sterling Heights, Macomb County.

Circuits

Two 120,000 volt, 60 cycle, 3 phase transmission lines with one ground wire.

Towers and Crossarms

See attached drawing T-7567, (D)

Conductors

Six 795 MCM 45/7 ACSR with one 3/8" steel ground wire.

Insulators

Eight 5 3/4" x 9 1/2" per phase in suspension.

Nine 5 3/4" x 10" per phase in deadend.

Guy and Guy Attachments

None

Suspension and Deadend Details

See attached drawing ED1-7572

RECORDED RIGHT OF WAY NO.

330014

System Engineering Department
CVP/bf 6/16/80

**Detroit
Edison**

2000 Second Avenue
Detroit, Michigan 48226
(313) 237-8000

RX-4329

March 23, 1981

Mr. David Wilson
Acting Utilities-Permits Engineer
Department of Transportation
18101 Nine Mile Road
Southfield, Michigan 48075

APPROVED

MAR 27 1981
David B. Wilson
DIST. UTILITY ENGINEER
MICHIGAN STATE HIGHWAY DEPT.

Gentlemen:

The Detroit Edison Company has an existing overhead transmission line in the City of Sterling Heights, Macomb County, Michigan.

The Consolidated Rail Corporation has constructed a new track under the above transmission line which consists of:

Two 120,000 volt, 60 cycle, 3 phase transmission lines with one ground wire.

Conductors:

Six 795 MCM 45/7 ACSR with one 3/8" steel ground wire.

Insulators:

Eight 5 3/4" x 9 1/2" per phase in suspension.

Nine 5 3/4" x 10" per phase in deadend.

As per my conversation with Eugene Barnes, Detroit Edison has prior rights to the property and no waiver is required. Easement rights were granted to Detroit Edison (Copy Enclosed)

The crossing is shown on drawing No. RX 4329. This is a new crossing.

Please grant a State Highway Permit to the Detroit Edison Company for the crossing.

DO NOT WRITE IN THIS BOX		
Application No. <i>50000-4-81</i>		
Permit No. <i>ME-109-81</i>		
Date of Issuance <i>3-27-81</i>		
Fee Amount <i>10.00</i>	Date <i>3-27-81</i>	
Cash	Bill <i>X</i>	By <i>HAO</i>

RECEIVED

MAR 25 1981

Utilities-Permits Division
Mich. Dept. of State Highways

Very truly yours,

R. G. DuPont

R. G. DuPont
Office Supervisor
Real Estate & R/W Department
406 G. O.

RGD:ss

Enc.

RECORDED RIGHT OF WAY NO. 33814

DATA SHEET TO ACCOMPANY DRAWING RX -4329

326

Name of Company

The Detroit Edison Company

Name and Location of Crossing

Crossing of the Chestnut - Sterling (Logan), and the Northeast - Sterling (Logan) (Skylark) 120kV circuits over the Consolidated Rail Corp. approximately 420 feet north of 16 Mile Road, and approximately 2,640 feet west of Van Dyke Ave.

Located in the southwest $\frac{1}{4}$ of section 21, City of Sterling Heights, Macomb County.

Circuits

Two 120,000 volt, 60 cycle, 3 phase transmission lines with one ground wire.

Towers and Crossarms

See attached drawing T-7567, (D)

Conductors

Six 795 MCM 45/7 ACSR with one 3/8" steel ground wire.

Insulators

Eight 5 3/4" x 9 1/2" pef phase in suspension.
Nine 5 3/4" x 10" per phase in deadend.

Guy and Guy Attachments

None

Suspension and Deadend Details

See attached drawing ED1-7572

RECORDED RIGHT OF WAY NO.

33814

System Engineering Department
CVP/bf 6/16/80

RECORDED RIGHT OF WAY NO. 33814

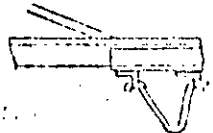
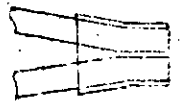
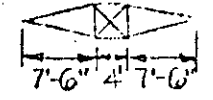
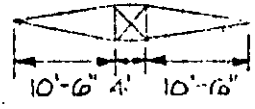

DETAIL OF END OF CROSSARM "D" & "DA"

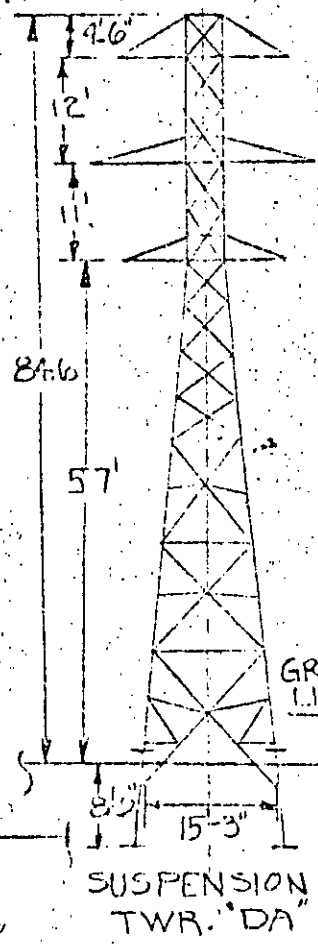
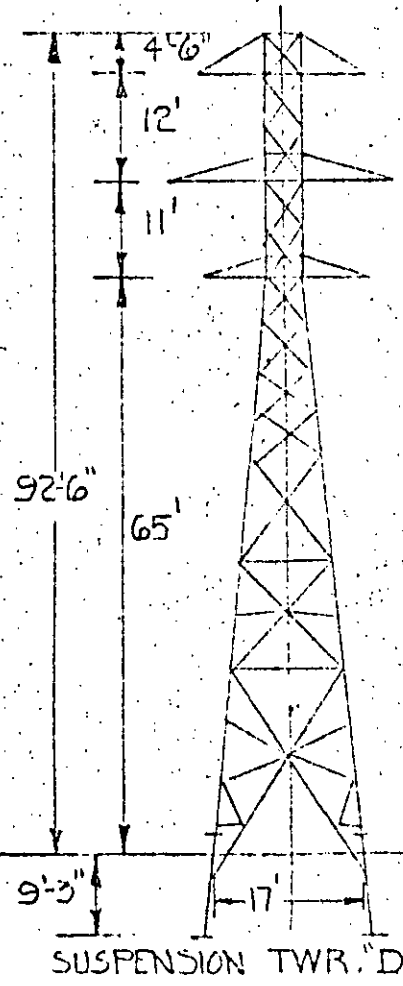

GRILLAGE

GROUND LINE

9'-3"

17'

SUSPENSION TWR. "D"

8'-3"

15'-3"

SUSPENSION TWR. "DA"

GROUND LINE

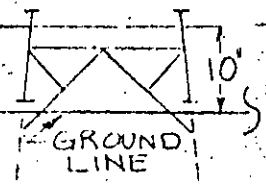

GROUND LINE

10' EXTENSIONS

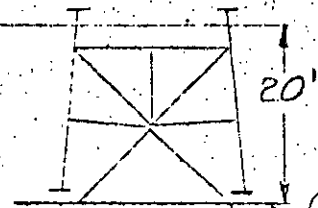

20'

GROUND LINE

20' EXTENSIONS

DETROIT EDISON CO. STRAIN TOWER "D" & "DA"		APPROVED	THE DETROIT EDISON COMPANY GENERAL ENGINEERING DEPARTMENT	
			LAYOUT BY	DRAWN BY C. VAIL PARR
		DATE 5-5-71	DRAWING NUMBER	
		SCALE	ED 1-7567	

DETAILS

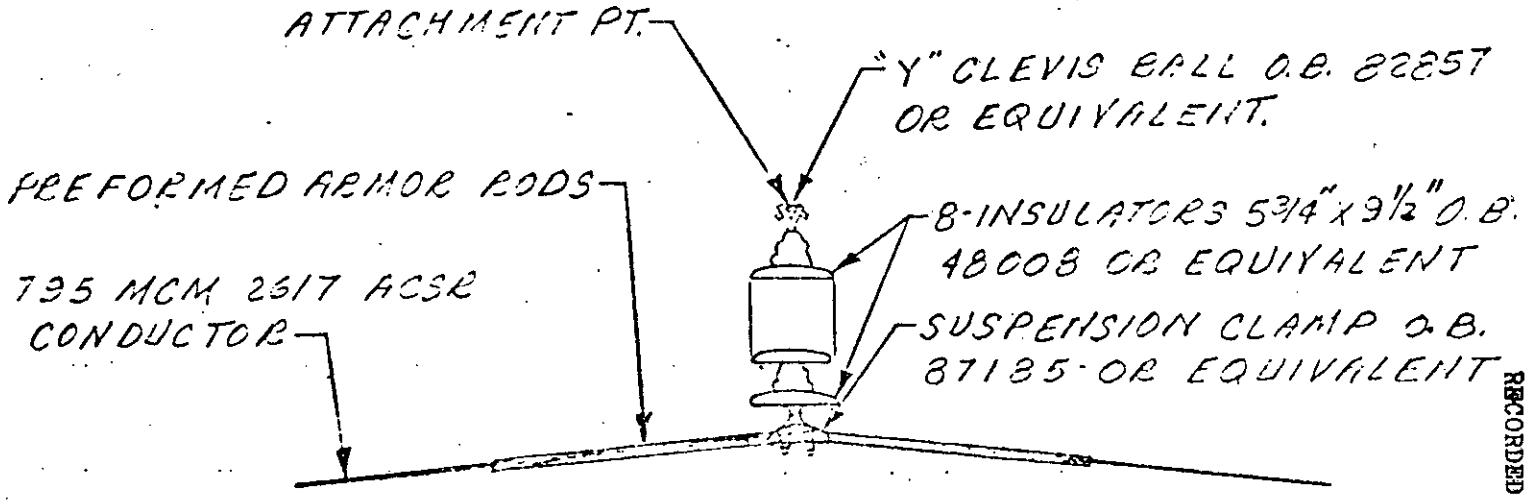

RECORDED RIGHT OF WAY NO. 33814

DEADEND ASS'Y
DETAILS

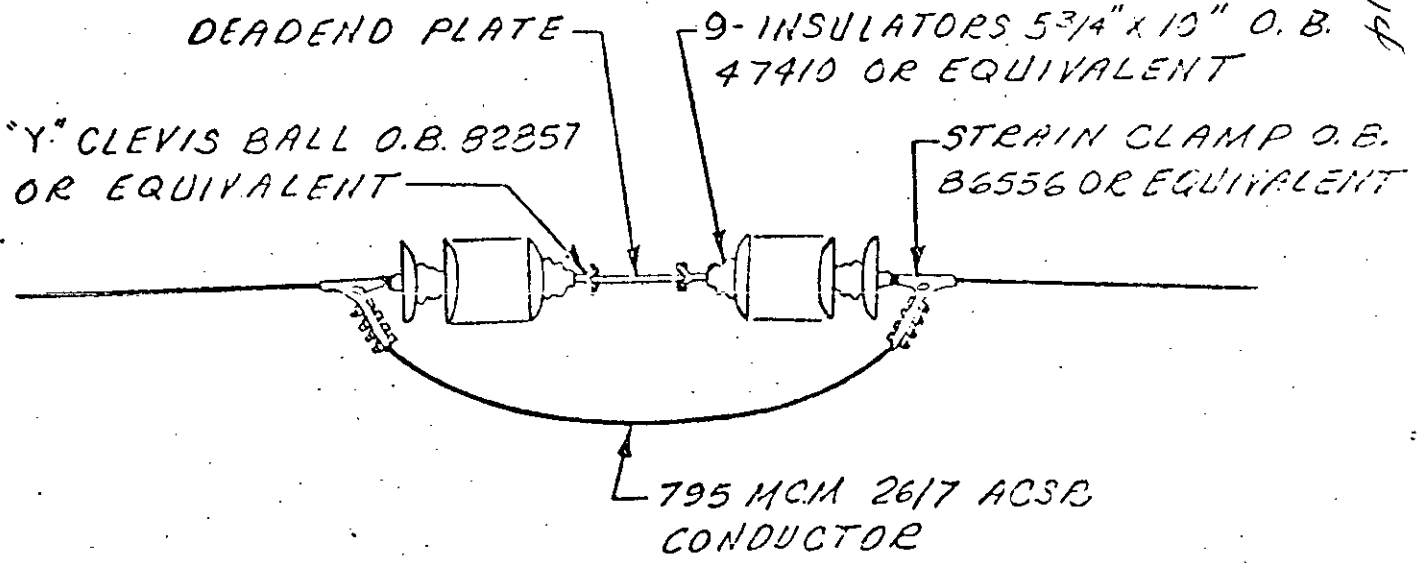

REV A 1-21-77 W.E.Z.

120 KV SUSPENSION &
DEADEND ASS'Y DETAILS

APPROVED	THE DETROIT EDISON COMPANY GENERAL ENGINEERING DEPARTMENT	
	LAYOUT BY J. W. SMITH	DRAWN BY
	DATE 5-7-71	DRAWING NUMBER
	SCALE	ED1-7572

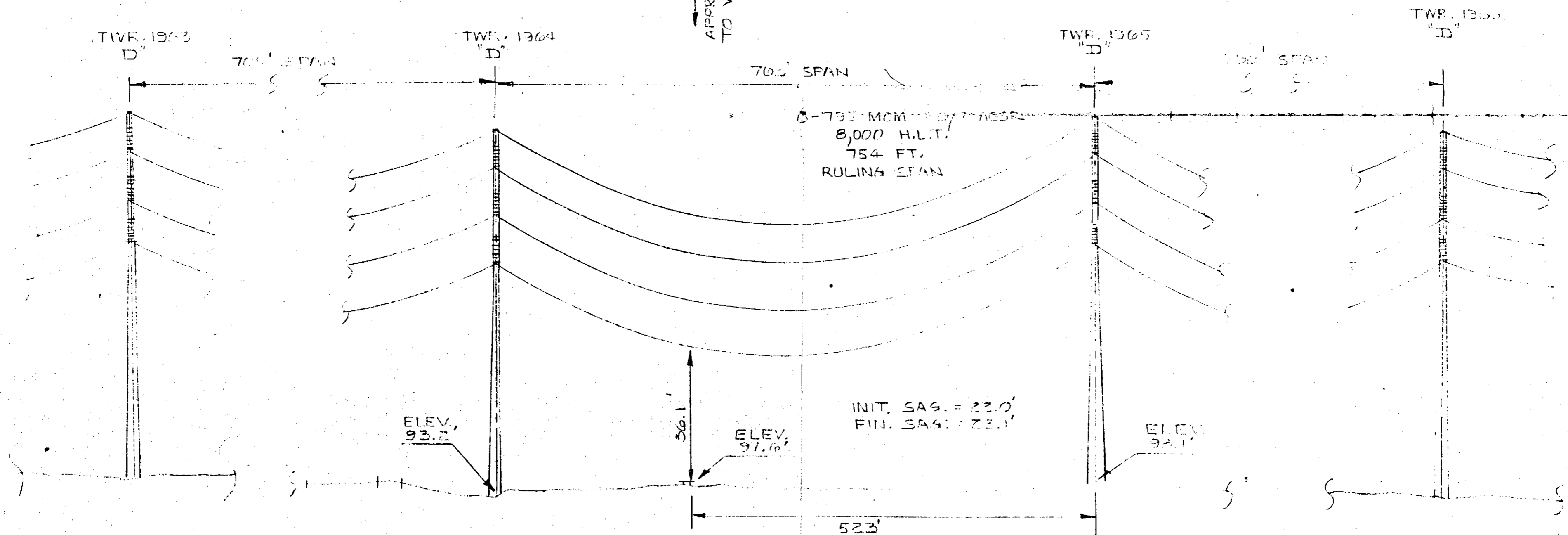
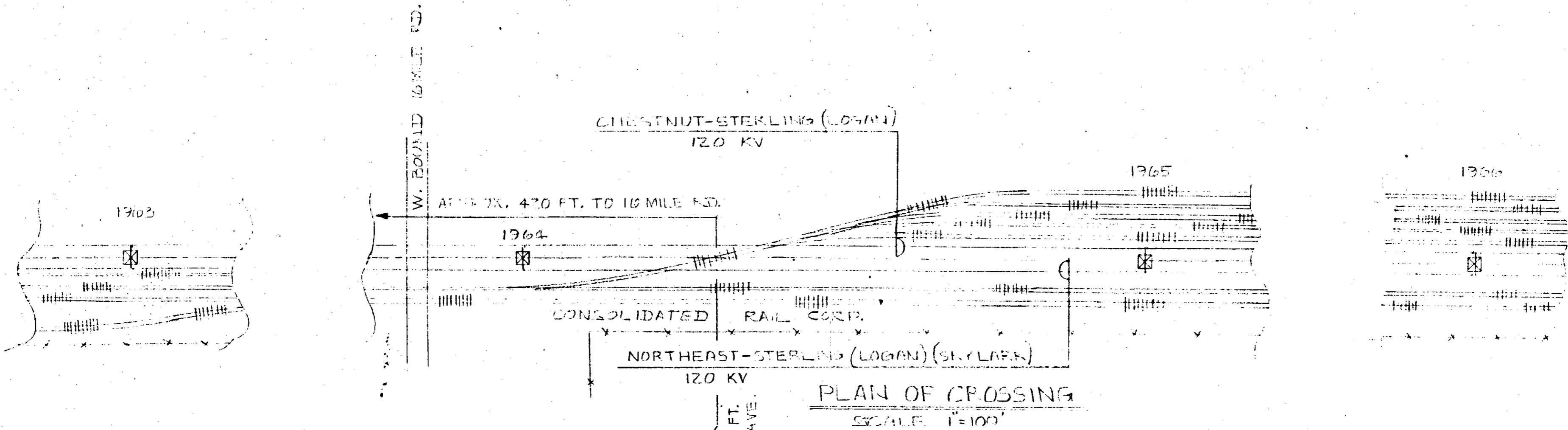
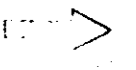

ALL DIMENSIONS AT 60° FINAL

THE DETROIT EDISON COMPANY

PLAN SUBMITTED TO
MICHIGAN DEPT. OF TRANSPORTATION
MICHIGAN PUBLIC SERVICE COMMISSION

FOR 120,000 VOLT CROSSING
OVER CONSOLIDATED RAIL CORP.

DRAWN BY C. VAN PARIS DATE 6-11-30
APPROVED BY J. G. [Signature] DATE 6-11-30

PERMIT NO. ED	DRAWING NO. RX-4329
-------------------------	-------------------------------

CITY STERLING HEIGHTS
COUNTY MACOMB
TOWNSHIP _____
SECTION NO. S.W. 1/4 SEC. 21

RECORDED RIGHT OF WAY NO. 33814

To: Records Center

From: Sharon Sounart
Real Estate and Rights of Way Department

Subject: Approximately 420 Feet North of 16 Mile Road and
Approximately 2,640 Feet West of Van Dyke Avenue.
Located in the Southwest ¼ of Section 21, City of
Sterling Heights, Macomb Count.

The attached papers are for records center storage. Information
about the completed transaction is shown in the following summary.

Council RR

R.R. 1	R.R. INVOICE NO. M.P.S.C. NO. OR R.E. & R/W NO. 4	Update 10 Type	D.E.C.O. RECORDS CENTER FILE NO. 15	R.X. NO. OR MAP NO. 20	Facility 21	Agreement Date 17
09	ME10981	1		4329	2	X'X'X'X'X'

Payment Frequency 28	Rental 21 33	OH-UG Code 34	Division 35	County 36	City or Township 38 44	Section 45
X	X'X'X'X'X'	1	3	06	STERLING	21

Location																									
41										80															
42	0	F	T	W	1	6	M	E	R	D	3	2	6	4	0	F	T	W	V	A	N	D	Y	K	E

Update Type Codes
 1 = New Agreement
 2 = Revised Agreement
 3 = Terminated Agreement

The ~~Accounts Payable~~ Department is requested to start or change
the rental payment effective

Approved *R. Sounart*

- cc: Accounts Payable
 Service Planning
 System Engineering
 Transmission & Distribution

RECORDED RIGHT OF WAY NO. 33814

**Detroit
Edison**

2000 Second Avenue
Detroit, Michigan 48226
(313) 237-8000

March 23, 1981

Mr. David Wilson
Acting Utilities-Permits Engineer
Department of Transportation
18101 Nine Mile Road
Southfield, Michigan 48075

APPROVED

MAR 27 1981

David B. Wilson
DIST. UTILITY ENGINEER
MICHIGAN STATE HIGHWAY DEPT.

Gentlemen:

The Detroit Edison Company has an existing overhead transmission line in the City of Sterling Heights, Macomb County, Michigan.

The Consolidated Rail Corporation has constructed a new track under the above transmission line which consists of:

Two 120,000 volt, 60 cycle, 3 phase transmission lines with one ground wire.

Conductors:

Six 795 MCM 45/7 ACSR with one 3/8" steel ground wire.

Insulators:

Eight 5 3/4" x 9 1/2" per phase in suspension.

Nine 5 3/4" x 10" per phase in deadend.

As per my conversation with Eugene Barnes, Detroit Edison has prior rights to the property and no waiver is required. Easement rights were granted to Detroit Edison (Copy Enclosed)

The crossing is shown on drawing No. RX 4329. This is a new crossing.

Please grant a State Highway Permit to the Detroit Edison Company for the crossing.

DO NOT WRITE IN THIS BOX		
Application No. 50000-4-81		
Permit No. ME-109-81		
Date of Issuance 3-27-81		
Fee Amount 10.00	Date 3-27-81	
Cash	By X	By HAO

RECEIVED

MAR 25 1981

Utilities-Permits Division
Mich. Dept. of State Highways

Very truly yours,

R. G. DuPont

R. G. DuPont
Office Supervisor
Real Estate & R/W Department
406 G. O.

RGD:ss

Enc.

RECORDED RIGHT OF WAY NO.

33814

DATA SHEET TO ACCOMPANY DRAWING RX -4329

Name of Company

The Detroit Edison Company

Name and Location of Crossing

Crossing of the Chestnut - Sterling (Logan), and the Northeast - Sterling (Logan) (Skylark) 120kV circuits over the Consolidated Rail Corp. approximately 420 feet north of 16 Mile Road, and approximately 2,640 feet west of Van Dyke Ave.

Located in the southwest $\frac{1}{4}$ of section 21, City of Sterling Heights, Macomb County.

Circuits

Two 120,000 volt, 60 cycle, 3 phase transmission lines with one ground wire.

Towers and Crossarms

See attached drawing T-7567, (D)

Conductors

Six 795 MCM 45/7 ACSR with one 3/8" steel ground wire.

Insulators

Eight 5 3/4" x 9 1/2" per phase in suspension.
Nine 5 3/4" x 10" per phase in deadend.

Guy and Guy Attachments

None

Suspension and Deadend Details

See attached drawing ED1-7572

System Engineering Department
CVP/bf 6/16/80

RECORDED RIGHT OF WAY NO.

33814

33814

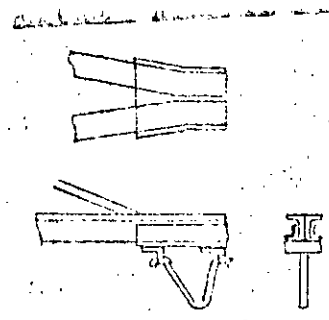
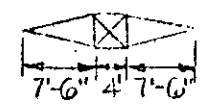
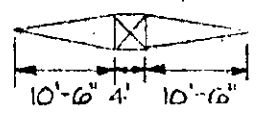

DETAIL OF END OF CROSSARM 'D' & 'DA'

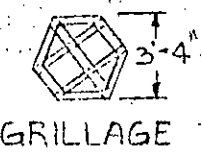
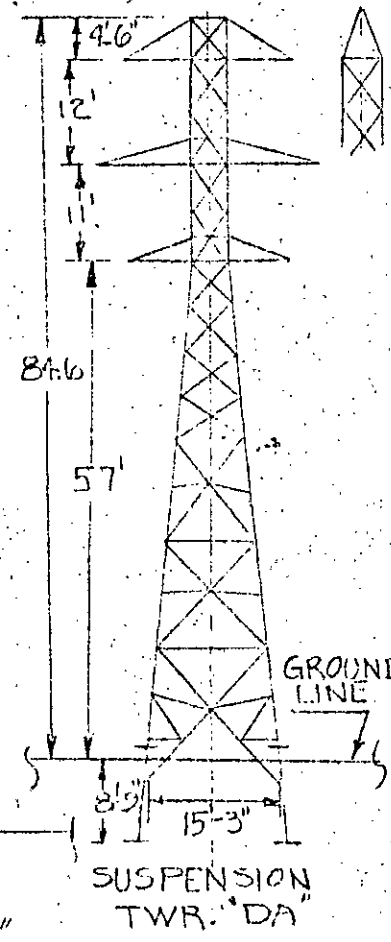
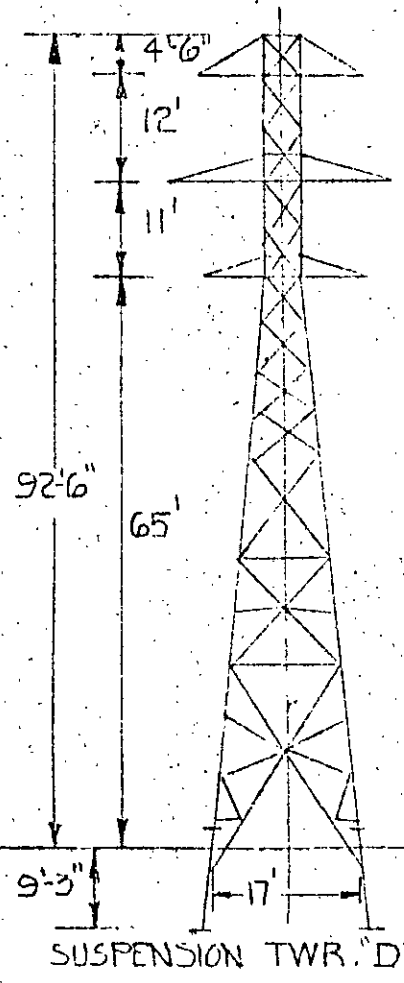

GRILLAGE

GROUND LINE

GROUND LINE

GROUND LINE

GROUND LINE

SUSPENSION TWR. "DA"

10' EXTENSIONS

20' EXTENSIONS

DETROIT EDISON CO.
STRAIN TOWER "D" & "DA"

APPROVED	THE DETROIT EDISON COMPANY GENERAL ENGINEERING DEPARTMENT	
	LAYOUT BY	DRAWN BY C. VAN PARI
	DATE 5-5-71	DRAWING NUMBER
	SCALE	ED 1-7567

DETAILS

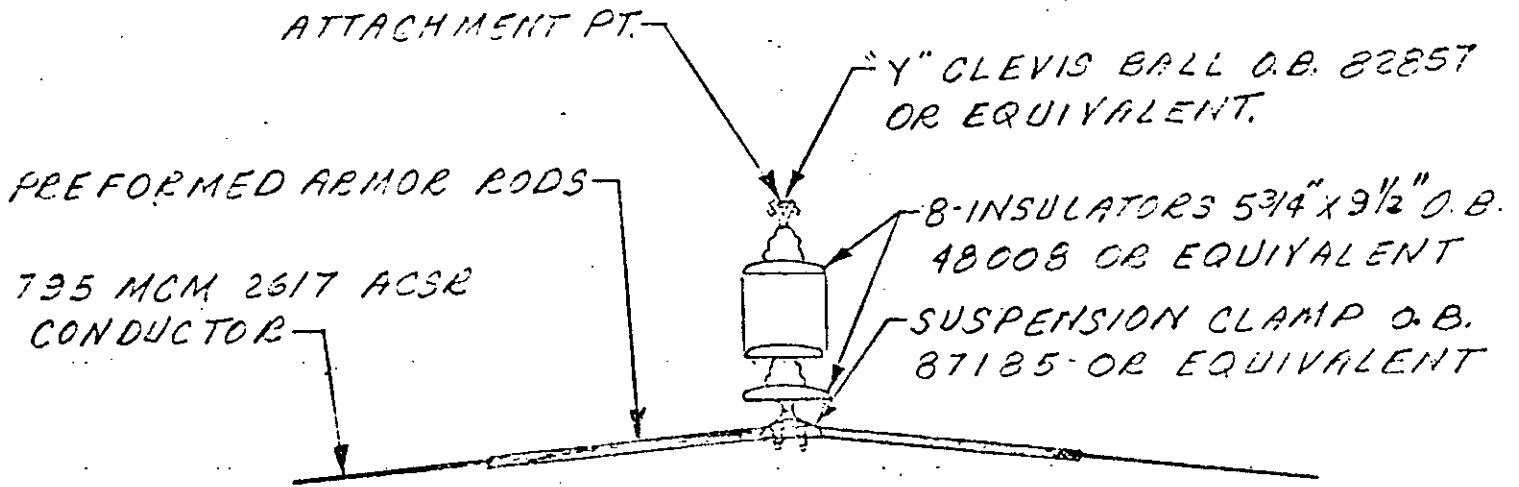

DEADEND ASS'Y
DETAILS

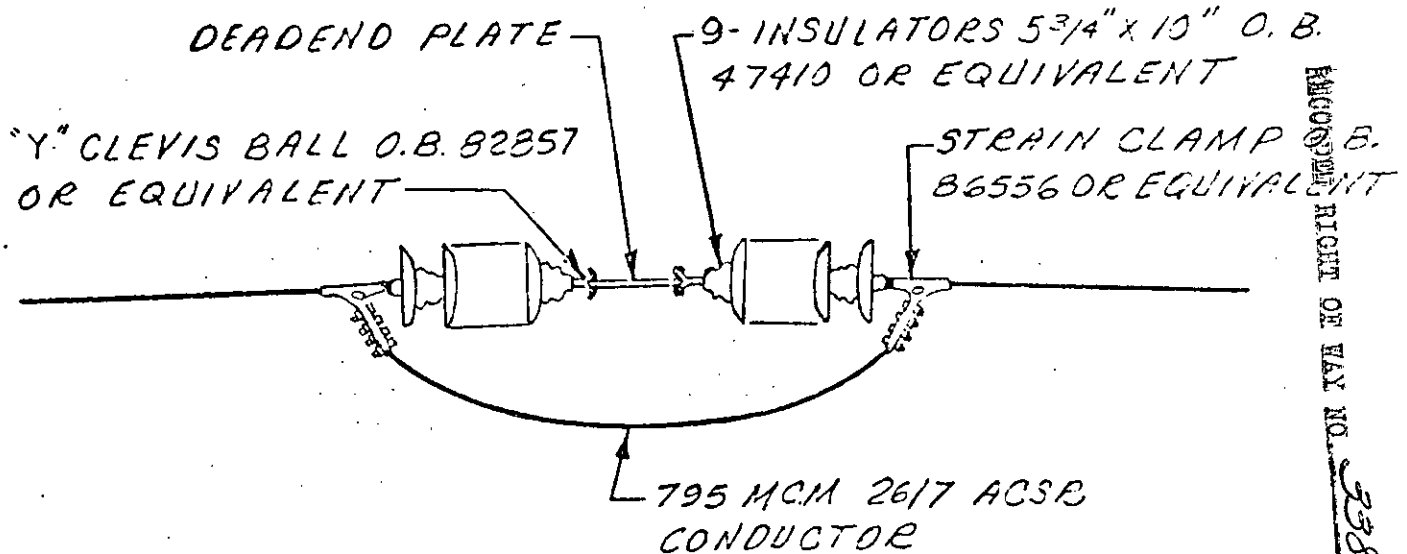

ENCLOSURE RIGHT OF WAY NO. 33814

REV A 4-23-77 152

120 KV SUSPENSION &
DEADEND ASS'Y DETAILS

APPROVED	THE DETROIT EDISON COMPANY GENERAL ENGINEERING DEPARTMENT	
LAYOUT BY J. W. [signature]	DRAWN BY [signature]	
DATE 5-7-71	DRAWING NUMBER	
SCALE	ED1-7572	

**Detroit
Edison**

2000 Second Avenue
Detroit, Michigan 48226
(313) 237-8000

DE 326 ✓

Mr. R. W. Orr
Assistant Vice President-Contracts
Consolidated Rail Corporation
1528 Walnut St. 8th Floor
Philadelphia, Pennsylvania 19102
Proposed Overhead Wire Crossing:

June 17, 1980

BT 9995

Circuits:

Two 120,000 volt, 60 cycle, 3 phase transmission lines with one ground wire.

Conductors:

Six 795 MCM 45/7 ACSR with one 3/8" steel ground wire.

Insulators:

Eight 5 3/4" x 9 1/2" per phase in suspension.

Nine 5 3/4" x 10" per phase in deadend.

Specific Location

Crossing of the Chestnut-Sterling (Logan), and the Northeast-Sterling (Logan) (Skylark) 120-kV circuits over the Consolidated Rail Corp. approximately 420 feet north of 16 Mile Road, and approximately 2,640 feet west of Van Dyke Ave.

Located in the southwest 1/4 of Section 21, City of Sterling Heights, Macomb County.

R. R. Valuation Station _____ R. R. Mile Post _____

City/Village Sterling Heights Township Sterling

County Macomb Detroit Edison Plan Attached 4329

This is a New Crossing XX This is a Reconstruction of Existing Crossing _____

Previous Agreement Information (if any) Date _____ (R. R. Plan) _____

Blanket Waiver of Hearing Covers _____ Waiver of Hearing Requested XX

(Waiver of Hearing to be mailed to applicant listed below)

All construction will be done in accordance with the rules and regulations of the Michigan Public Service Commission.

R. G. DuPont
R. G. DuPont
Office Supervisor
Real Estate & Rights of
Way Department
406 G. O.

RECORDED
RIGHTS
OF
WAY
NO.

33814

CONRAIL

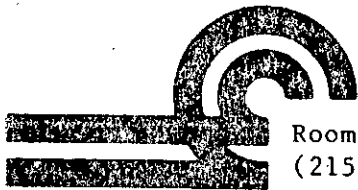

Room 801
(215) 893-6409

March 5, 1981
File: DE-326

The Detroit Edison Company
2000 Second Avenue
Detroit, Michigan 48226

Attn: R. G. DuPont
Office Supervisor
Real Estate and R/W Dept.

Gentlemen:

Reference is made to your letter dated June 17, 1980 attaching copies of your drawing RX-4329 indicating your proposed installation of an aerial crossing of two (2) 120,000-volt circuits each consisting of three (3) conductors and one (1) neutral wire crossing over tracks of Railroad located at Valuation Station 938+40+, at a point 329 feet south of Mile Post 20 and 3.88 miles south of the Station of Utica, Macomb County, Michigan.

We have no objections to the installation as mentioned above with the understanding that the abovementioned facilities will be installed in a safe and satisfactory manner and in accordance with the "General Conditions" hereto attached and made a part hereof. You will be required to notify: R. D. Lowery, Engineer of Construction, Chicago, Illinois, Tele: 312-236-7200, x2400 at least seven (7) working days prior to start of work.

It is to be understood that this installation must be made in accordance with the approved plans and will conform with current Consolidated Rail Corporation construction requirements.

Consolidated Rail Corporation hereby waives hearing in regard to your Company making the abovementioned construction provided the work is done in a safe and satisfactory manner and subject to the rules and regulations of the Michigan Public Service Commission.

Your draft in the amount of \$ 250.00 to cover the preparation fee under the agreement is to be forwarded when all copies of the agreement are returned to this office.

To confirm your acceptance of these conditions, please have an authorized official of your Company indicate acceptance in the space provided on the duplicate of this letter and return it to this office. It is to be further understood that no work can be started until the signed copy of this letter is received in this office and the notification procedures as stated above have been accomplished.

CONSOLIDATED RAIL CORPORATION

R. W. Orr

R. W. Orr, Assistant Vice President - Contracts
CONSOLIDATED RAIL CORPORATION 1528 WALNUT STREET PHILADELPHIA, PA 19102

RECORDED
EIGHT

SE
MAY
NO.

33814

11/22/76

CONSOLIDATED RAIL CORPORATION
1528 Walnut Street

PHILADELPHIA, PENNSYLVANIA 19104

GENERAL CONDITIONS

1. Facilities must conform with all Federal, State and local laws, rules and regulations and will not be attached to any Railroad structure or appurtenance and will not otherwise be located on any private property of the Railroad.

2. In the event of any revision, renewal, addition or alteration of said facilities, prior approval of the Railroad must be secured.

3. Facilities will be installed, maintained, repaired and renewed by and at the sole risk, cost and expense of the OWNER.

4. If the Railroad deems it advisable during the progress of any work of construction, maintenance, repairs and renewals, alterations, adjustments or removal of the facilities and appurtenances of the OWNER, or in the event of emergency, to place watchmen, flagmen, inspectors or any other employees deemed necessary by Railroad for the protection of the property owned or in possession or control of the Railroad, or its employees, patrons, or licensees, the Railroad shall have the right to do so. The OWNER agrees to pay to Railroad the actual cost of material plus the current applicable overhead percentages for storage, handling, transportation, purchasing and other related material management expenses and the actual cost of labor plus the current applicable overhead percentages as developed and published by the Accounting Department of Railroad for fringe benefits, payroll taxes, administration, supervision, use of tools, machinery and other equipment, supplies, employers' liability insurance, public liability insurance, and other insurance, taxes and all other indirect expenses. It is to be understood that the aforementioned material and labor overhead charges are to be applied at the rates which are effective at the time of the performance of any work by employees of the Railroad on the said facilities. The OWNER agrees to pay such bills within thirty (30) days of the presentation thereof by Railroad. Failure of the Railroad to provide such watchmen, flagmen, inspectors or any other employees of Railroad, shall in no event be construed as in any manner or degree affecting any obligations of the OWNER as provided for elsewhere in these conditions.

5. All cost or expense resulting from any and all loss of life or property, or injury or damage to the person or property of any person, firm or corporation (including the parties hereto and their respective officers, agents and employees) and any and all claims, demands or actions for such loss, injury or damage, caused by or growing out of the presence or use, or the construction, maintenance, renewal, change or relocation and subsequent removal of said facilities and appurtenances herein referred to, caused by or from the joint or concurring negligence of both parties hereto shall be borne by them equally; if, however, any such loss, injury or damage shall be attributed to the negligence of one of the parties hereto, where solely or combined with the negligence of any other person or corporation not a party hereto, and without the concurring fault or negligence of the other party hereto, then such party hereto which by its fault, or negligence contributed thereto shall indemnify, protect and save harmless the other party hereto therefrom.

6. Upon abandonment of the facilities, the same shall be removed and the property of the Railroad shall be restored to good condition and this instrument shall become null and void, save and except only as to any liability accrued prior thereto.

7. All rights and obligations conferred hereby shall extend to the successors and assigns of the parties hereto, provided that the owner shall in no event transfer or assign its rights hereunder without the written consent of Railroad".

REPRODUCED
BY
11/22/76
53814

NORTH ARROW

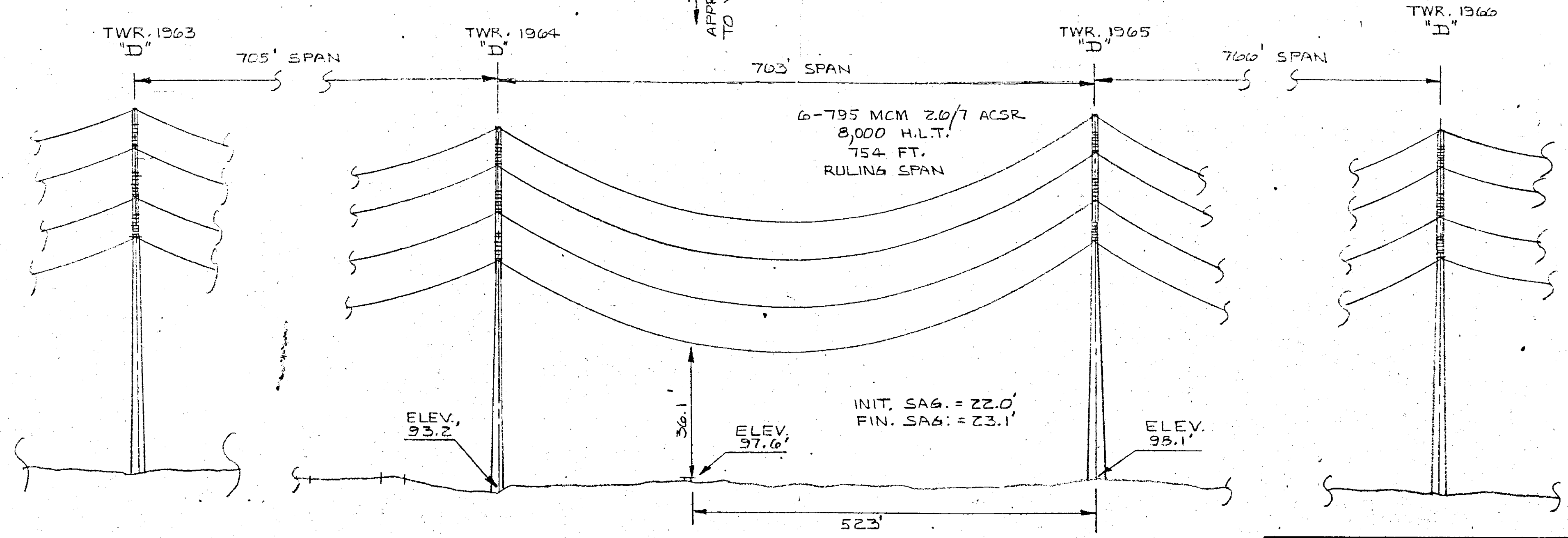
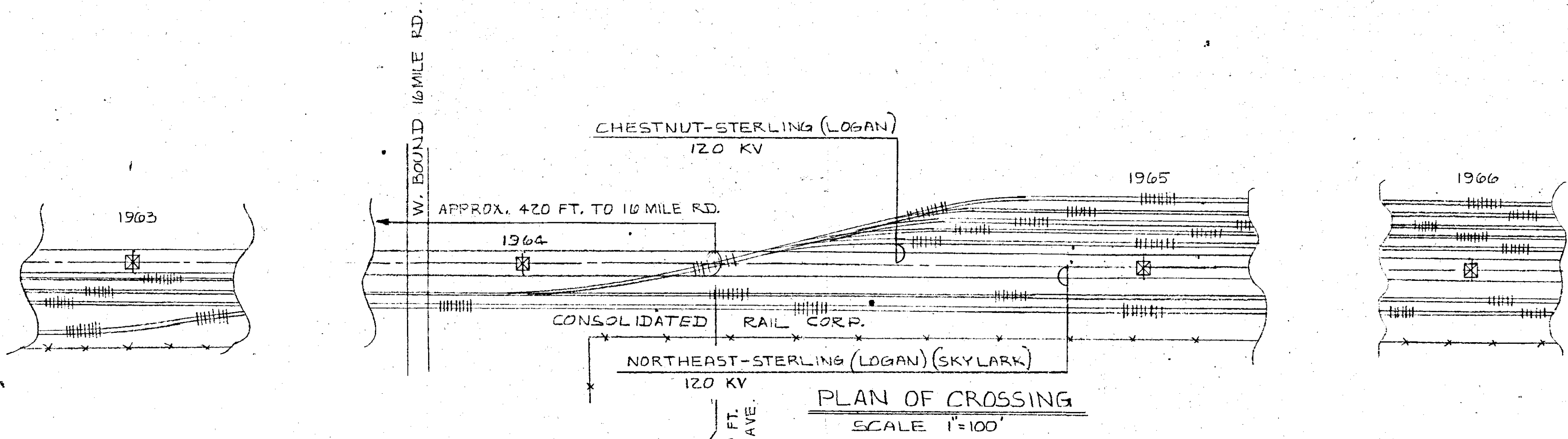
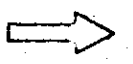

ALL DIMENSIONS AT 60° FINAL

ELEVATION OF CROSSING
SCALE: HOR: 1"=100'
VERT: 1"=20'

CITY STERLING HEIGHTS
 COUNTY MACOMB
 TOWNSHIP _____
 SECTION NO. S.W. 1/4 SEC. 21

THE DETROIT EDISON COMPANY

PLAN SUBMITTED TO
 MICHIGAN DEPT. OF TRANSPORTATION
 MICHIGAN PUBLIC SERVICE COMMISSION

FOR 120,000 VOLT CROSSING
 OVER CONSOLIDATED RAIL CORP.
 DRAWN BY C. VAN PARIS DATE 6-11-80
 APPROVED BY *J. House* DATE 6-11-80

PERMIT NO. ED	DRAWING NO. RX-4329
-------------------------	-------------------------------

RECORDED RIGHT OF WAY NO. 33814



Real Estate Department

Project No. XMA0144012
Work Order No. A0003507
Business Unit: ITC

Date: July 11, 2014
To: Records Center
From: Trina Richardson
Real Estate
Subject: Consolidated Railway Corporation-Section 21, City of Sterling Heights, Macomb County, Michigan.

Attached are papers related to the acquisition of a Permit-to-Enter, dated March 13, 2014 to International Transmission Company (ITC) from Consolidated Railway Corporation, whose address is 1000 Howard Blvd- 4th Floor, Mt. Laurel, NJ 08056.

The license was acquired for the Sloan- Sterling 120kV transmission line.

The license consideration was \$1,500.00.

The acquisition was negotiated by Trina Richardson.

Please incorporate into Right of Way File No. R33814.

Attachment (s)

CONRAIL®



Sloan - Sterling 6
A0003507



January 8, 2014

Ms. Trina Richardson
Property Management Specialist
ITC Transmission
27175 Energy Way
Novi, Michigan 48377

SUBJECT: Temporary License to enter upon the property of CONRAIL for the purpose of performing of making insulator modifications and raising conductor, as described in the application package dated February 28, 2014

Dear Ms. Richardson:

Reference permit to enter dated March 13, 2014; the location of subject work is incorrectly recorded in the temporary license agreement permitting entry onto Conrail property in connection with the above project.

With this letter, Conrail revises the Agreement to grant entry to Conrail's property at Sterling Secondary Track, Line Code 50-5233, near Mile Post 20.0+/- in Sterling Heights, County of Macomb, State of Michigan. All other sections of the temporary license remain unchanged. Please have this letter and a copy of the original temporary license with you at all times while on Conrail property.

Please Contact Project Engineer Carl Young, at Phone Number (734) 834-6551, to arrange to enter onto Conrail Property.

If you have any questions, you can contact me at the number below.

Sincerely,

A handwritten signature in blue ink that reads 'Maria Bourassa'.

Maria Bourassa
Manager - Engineering Contracts
856-231-2454

FILE
R101433 P2

CONSOLIDATED RAIL CORPORATION
TEMPORARY LICENSE PERMITTING ENTRY ON PROPERTY

THIS AGREEMENT, dated March 13, 2014, between INTERNATIONAL TRANSMISSION COMPANY, here in after called "Licensee" and CONSOLIDATED RAIL CORPORATION, a corporation of the Commonwealth of Pennsylvania, hereinafter called "CONRAIL".

WHEREAS, Licensee, has requested permission to enter upon the property of CONRAIL; and

WHEREAS, CONRAIL is willing to grant a temporary License for such entry; subject to the terms and conditions hereinafter set forth.

NOW THEREFORE, CONRAIL and Licensee, intending to be legally bound, agree as follows:

1. PERMISSION, LOCATION AND ACCESS

CONRAIL hereby grants to Licensee, insofar as it has the legal right and its present title permits, a temporary License to enter upon the property of CONRAIL for the purpose of making insulator modifications and raising conductor, as described in the application package dated February 28, 2014, located on or near CONRAIL's Sterling Secondary Track, LC 50-5223, from Mile Post MP 20.0+/- to Mile Post 22.5+/-, in the City of Lincoln Park and the City of Sterling Heights, County of Macomb, State of Michigan.

2. LIABILITY

Licensee hereby releases and will protect, defend, indemnify and save harmless CONRAIL and its subsidiaries, and their officers, agents and employees, against all claims, liabilities, demands, actions at law and equity, judgments, settlements, losses, damages and expenses of every character whatsoever (hereinafter collectively referred to as "Claims") for injury (including death) sustained by the officers, agents and employees of CONRAIL and its subsidiaries, Licensee and any officers, agents and employees of Licensee, and all other persons whomsoever, and for damage to or loss or destruction of property of any kind by whomsoever owned, caused by, resulting from, arising out of, or occurring in connection with the entry or presence of Licensee and its officers, agents and employees on CONRAIL property or incidental to or appertaining thereto, and whether or not such injury (including death) and such damage to or loss or destruction of property are due to or chargeable to, in whole or part, any alleged active or passive negligence or participation in the wrong or upon any alleged breach of any statutory duty or obligation by CONRAIL or any subsidiary, including their officers, agents and employees. As a result of any such Claims, Licensee will assume at its own expense, on behalf of CONRAIL and its subsidiaries, and their officers, agents and employees, the defense of any such Claims which may be brought against said parties and pay on behalf of said parties the amount of any settlement agreed upon, judgment that may be entered, and any other amounts assessed in connection therewith, plus all costs and expenses involved as aforementioned.

3. CONSIDERATION

Licensee will pay to **CONRAIL**, the sum of One Thousand Five Hundred Dollars (\$1,500.00) as a compensation for the preparation of this License and Railroad Protective Liability Insurance.

4. ENTRY UPON PROPERTY

Licensee shall notify CONRAIL's Chief Engineer, or his designee, at least fourteen (14) working days in advance before entering upon or starting any work upon CONRAIL property. No entry or use of CONRAIL property will be permitted until this License is signed, charges hereunder paid, evidence of any insurance coverage required under paragraph 10 hereof has been received and accepted by CONRAIL, and permission received from the designee of the Chief Engineer who will be William K. Kaeser-Director Design & Construction, 1000 Howard Boulevard, Room 470, Mt Laurel, NJ 08054.

5. CONRAIL OPERATIONS

All operations of Licensee shall be carried on in such a manner so as not to interfere with CONRAIL property and operations or the use of any CONRAIL facilities. If in the opinion of the Chief Engineer or his designee conditions warrant at any time, CONRAIL will provide flag protection, signal/communication line protection and engineering inspection at the expense of Licensee and Licensee will pay to CONRAIL the full cost and expense therefor. All work done by Licensee will be in accordance with CONRAIL's CE-6 Specifications.

6. CROSSING OR FOULING TRACK

In no event shall equipment or material be transported across CONRAIL's track or tracks without special permission and with advance notice of at least seven (7) days so that CONRAIL may arrange for the necessary flag protection at the expense of Licensee and Licensee will pay to CONRAIL the full cost and expense therefor. Such permission shall be obtained from CONRAIL's Chief Engineer or his designee. Licensee agrees not to enter upon or foul track until given signal to do so by a flagman.

7. CLEARANCES

All equipment working on or material in use upon the property of CONRAIL shall be kept at all times not less than twelve feet (12') from the nearest rail of any track, or as subsequently modified in writing by CONRAIL's Chief Engineer or his designee. Licensee shall conduct its operations so that no part of its equipment shall foul an operating track, transmission, signal or communication line, or any other structure of CONRAIL.

8. RESTORATION OF PREMISES

Upon completion of the work, CONRAIL's property shall be left in a condition satisfactory to CONRAIL's Chief Engineer or his designee. This includes, without limitation, immediate restoration of any fences removed.

9. TERM OF LICENSE

CONRAIL reserves the right to revoke this License at any time. Unless modified or terminated, this license shall extend until September 30, 2014 at which time it shall expire automatically. Licensee will notify CONRAIL's Chief Engineer or his designee when use of the property or work is completed. Under no circumstances shall this License be construed as granting Licensee any right, title or interest of any kind or character in or about the land or premises of CONRAIL.

10. INSURANCE

In addition to any other forms of insurance or bonds required under this License and except to the extent that any of the requirements of this section are expressly waived or revised in writing by Conrail, Licensee, prior to the commencement of any work pursuant to this License and throughout the term of this License, shall, at its own cost and expense, maintain insurance of the following kinds and amounts and deliver to Conrail's Manager-Insurance and Conrail's Director-Design and Construction satisfactory evidence of such insurance as indicated herein.

(a) Public Liability insurance, including contractual liability insurance, with a limit of not less than \$5,000,000 combined single limit for bodily injury and/or property damage for damages arising out of bodily injuries to or death of all persons in any one occurrence and for damage to or destruction of property, including the loss of use thereof, in any one occurrence. Conrail shall be named as an additional insured under this insurance.

(b) Workers' Compensation insurance in Statutory Amounts. Employers' Liability and Occupational Disease Insurance with limits of \$1,000,000 each accident, \$1,000,000 policy limit and \$1,000,000 each employee. Such policy shall include a waiver of subrogation in favor of Conrail.

(c) Automobile Liability insurance with a limit of not less than \$5,000,000 combined single limit for bodily injury and/or property damage per occurrence. Conrail shall be named as an additional insured under this insurance.

(d) The insurance specified above shall be carried until the Project is satisfactorily completed and formally accepted by Conrail. Failure to procure and maintain such insurance shall constitute a Breach of this License.

(e) The above indicated insurance coverages shall be effected under standard form policies issued by insurers of financial responsibility that are rated "A" or better by Best's Insurance Reports, "AA" or better by Standard & Poor's Insurance Rating Service and "Aa" or better by Moody's Investors Service. Conrail reserves the right to reject as inadequate any insurance coverage provided by an insurance company that is rated less than the ratings above by any of the aforementioned rating services.

(f) The above indicated insurance coverages shall be enforceable by any legitimate claimant after the termination or cancellation of this License or any attachment hereto, whether by expiration of time, by operation of law or otherwise, so long as the basis of the claim against the insurance company occurred during the period of time when the License was in effect and the insurance was in force.

(g) Licensee shall furnish Conrail with certificates of insurance evidencing the insurance coverages required in subsections (a), (b), (c), etc., above, at least thirty (30) days prior to the commencement of this License. Conrail shall be named as an additional insured under the insurance coverages outlined in subsections (a), (b), (c) etc. above. Certificates of insurance and/or policies should be sent to Consolidated Rail Corporation, Director Design and Construction, 1000 Howard Boulevard – 4th Floor, Mount Laurel, NJ 08054-2355.

(h) All insurance policies shall be endorsed to provide that the insurance company shall give thirty (30) days prior written notice to Consolidated Rail Corporation, Director Design and Construction, 1000 Howard Boulevard – 4th Floor, Mount Laurel, NJ 08054-2355, if the policies are to be terminated or if any changes are to be made which will in any way affect the insurance requirements of this License.

IN WITNESS WHEREOF, the parties hereto have caused this License to be executed as of the date first above written.

WITNESS:

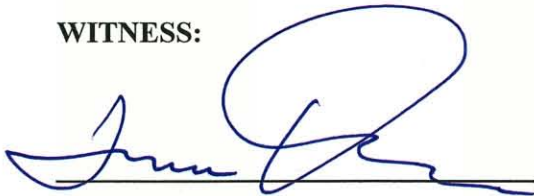

INTERNATIONAL TRANSMISSION COMPANY,
a MICHIGAN CORPORATION, d/b/a ITC TRANSMISSION
By: ITC HOLDINGS CORP., a MICHIGAN CORPORATION,
Its sole owner

BY:



CHRISTINE MASON SORELLA
VICE PRESIDENT AND GENERAL COUNSEL
UTILITY OPERATIONS

WITNESS:



CONSOLIDATED RAIL CORPORATION,

BY:

William Kaeser
Director-Engineering & Construction

Richardson, Trina

From: Bourassa, Maria <Maria.Bourassa@Conrail.com>
Sent: Monday, March 24, 2014 4:58 PM
To: Richardson, Trina
Cc: carl.young@urs.com
Subject: Conrail Entry Permit and Revision
Attachments: 1736_001.pdf

Trina,

The Entry Permit Agreement has been mailed to you. Please find attached an Amendment Letter to that Agreement, as the exact location on Conrail property was not correct.

Please attached a copy of this letter to your Entry Permit Agreement.

Thank you,

Maria Bourassa
Conrail
856-231-2454

CONRAIL®



January 8, 2014

Ms. Trina Richardson
Property Management Specialist
ITC Transmission
27175 Energy Way
Novi, Michigan 48377

SUBJECT: Temporary License to enter upon the property of CONRAIL for the purpose of performing of making insulator modifications and raising conductor, as described in the application package dated February 28, 2014

Dear Ms. Richardson:

Reference permit to enter dated March 13, 2014; the location of subject work is incorrectly recorded in the temporary license agreement permitting entry onto Conrail property in connection with the above project.

With this letter, Conrail revises the Agreement to grant entry to Conrail's property at Sterling Secondary Track, Line Code 50-5233, near Mile Post 20.0+/- in Sterling Heights, County of Macomb, State of Michigan. All other sections of the temporary license remain unchanged. Please have this letter and a copy of the original temporary license with you at all times while on Conrail property.

Please Contact Project Engineer Carl Young, at Phone Number (734) 834-6551, to arrange to enter onto Conrail Property.

If you have any questions, you can contact me at the number below.

Sincerely,

A handwritten signature in blue ink that reads "Maria Bourassa".

Maria Bourassa
Manager – Engineering Contracts
856-231-2454



420' TO CROSSING OF 16 MILE RD.

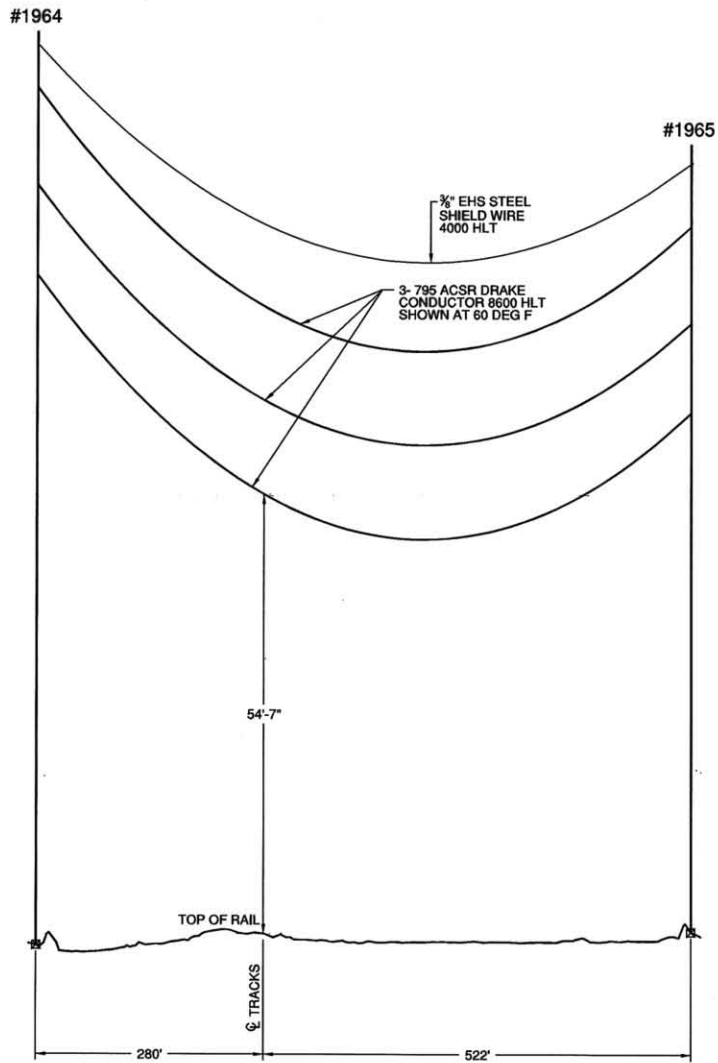
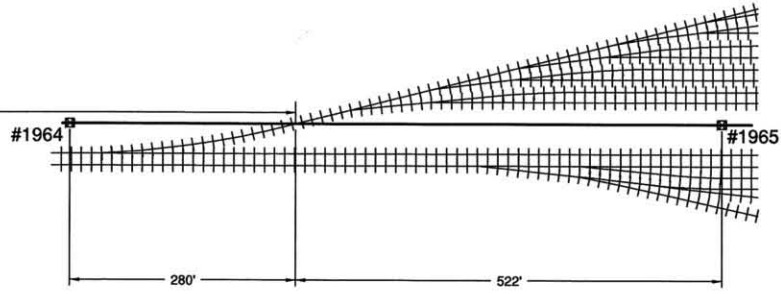

**SLOAN - STERLING
120 KV TRANSMISSION CROSSING
CONSOLIDATED RAIL CORPORATION
STR. # 1964-1965**

ITC		ENGINEERING	
DRAWN BY DSF/SMP/B&V	PROJECT NO. A0003507	DATE 3/5/14	SCALE N.T.S
CHECKED BY JRR/B&V	DRAWING NUMBER ITC4-24075	DATE 3/5/14	