

# **RAILROAD RIGHT OF WAY**

**DOCUMENT(S) WILL BE SCANNED  
AT A LATER TIME**

RECORDED RIGHT OF WAY NO. 233336

6/13/80

To: Records Center

From: Sharon Sounart  
Real Estate and Rights of Way Department

Subject: In Eckles Road and 1255' W. of Mile Post 325, 1 3/4 Miles E. of the City of Goodells, S.E. 1/4 of Section 1, Township of Wales, T6N, R15E, County of St. Clair.

The attached papers are for records center storage. Information about the completed transaction is shown in the following summary.

R.R. 1	R.R. INVOICE NO. M.P.S.C. NO. OR R.E. & RAW NO. 3	Update 10 Type	D.E.C.O. RECORDS CENTER FILE NO. 15	R.X. NO. OR MAP NO. 20	Facility 21	Agreement 22 Date 27
07	ME27980	1		1657A	1	X X X X X

*Sharon Sounart*

Payment Frequency 28	Rental 29 33	OH-UG 34 Code	Division 35	County 36	City or Township 38 44	Section 45
X	X X X X X	1	5	10	WALLES	01

Location																																	
41									50																								
E	C	K	L	E	S	R	D	1	2	5	S	F	T	W	M	P	3	2	5	1	3	1	4	M	E	6	0	0	D	E	L	L	S

Update Type Codes  
 1 = New Agreement  
 2 = Revised Agreement  
 3 = Terminated Agreement

The Accounts Payable Department is requested to start or change the rental payment effective

Approved: *L. Dubont*

- cc:  Accounts Payable  
 Service Planning  
 System Engineering  
 Transmission & Distribution

RECORDED RIGHT OF WAY NO. 33336

**Detroit  
Edison**

2000 Second Avenue  
Detroit, Michigan 48226  
(313) 237-8000

DO NOT WRITE IN THIS BOX		
Application No. 77000-23-80		
Permit No. ME-279-RR-80		
Date of Issuance 6/10/80		
Fee <b>ARRIVED</b>	Date	
Cash	Bill	By CLC

June 5, 1980

Mr. David Wilson  
Acting Utilities-Permits Engineer  
Department of Transportation  
18101 Nine Mile Road  
Southfield, MI 48075  
Gentlemen:

JUN 09 1980  
Utilities-Permits Division  
Mich. Dept. of State Highways

The Detroit Edison Company plans to construct, operate, and maintain an overhead line in City of Goodells, Township of Wales, St. Clair County

The line will cross the tracks of the Grand Trunk Western Railroad Company. The wires to be installed are:

Span B-C

Three 3/0 ACSR 4,800 volts.

The railroad has given the following waiver of hearing:

     Waiver dated                      enclosed  
XX Blanket Waiver on file with the MPSC.

The proposed crossing is shown on drawing No. RX-1657A

     This is a new crossing.  
XX This is a re-construction.

Please grant a State Highway Permit to the Detroit Edison Company for the proposed crossing.

Permit No. 77000-23-80 - ME-279-RR-80

Date 6/10/80

By David P. Wilson

District Utilities-Permits  
Engineer

Very truly yours,

R. G. DuPont  
R. G. DuPont  
Office Supervisor  
Real Estate & Rights of  
Way Department  
406 G. O.

/ss

D.E. FORM RR40 9-77 CS

RECORDED RIGHT OF WAY NO.

53336

**Detroit Edison**

2000 Second Avenue  
Detroit, Michigan 48226  
(313) 237-8000

Mr. W. LaMasters  
Engineer of Surveys & Construction  
Grand Trunk Western Railroad Company  
110 West Huron Street  
Pontiac, Michigan 48056  
Proposed Overhead Wire Crossing:

February 22, 1980

Span B-C

Three-3/0 ACSR 4,800 Volts

Specific Location

In Eckles Road and 1255' W. of Mi. Post 325, 1 3/4 Miles E. of the City of Goodells, S.E. 1/4, Section 1, Township of Wales, T6N, R15E, County of St. Clair.

RECORDED RIGHT OF WAY NO

R. R. Valuation Station \_\_\_\_\_ R. R. Mile Post \_\_\_\_\_

City/Village Goodells Township Wales

County St. Clair Detroit Edison Plan Attached RX 1657A

This is a New Crossing \_\_\_\_\_ This is a Reconstruction of Existing Crossing XX

Previous Agreement Information (if any) Date \_\_\_\_\_ (R. R. Plan) \_\_\_\_\_

33336

Blanket Waiver of Hearing Covers XX Waiver of Hearing Requested \_\_\_\_\_  
(Waiver of Hearing to be mailed to applicant listed below)

All construction will be done in accordance with the rules and regulations of the Michigan Public Service Commission.

  
Leslie G. Sundstrom  
Office Supervisor  
Real Estate & Rights of Way  
Department  
406 G.O.

Submit One (1) Copy for each Span to  
Real Estate and Rights of Way Dept.

D.O. No. B-77748

Date 2-13-80

THE DETROIT EDISON COMPANY

RAILROAD CROSSING DATA SHEET

RX 1657A

Span B-C

Revision of RX 1657

M.P.S.C. Permit and Date ED2-8-376

Railroad: GRAND TRUNK WESTERN

Facilities: 3-3/0 ACSR 4800 VOLTS

Location: IN ECKLES RD. AND 1255' W. OF MI. POST 325., 1 3/4 mi  
THE CITY OF  
E. OF GOODSELLS, SE 1/4, SECTION 1, TOWNSHIP OF WALES, T6N,  
R15, E, COUNTY OF ST. CLAIR.

System Engineering Dept.

Date 2-15-80

By F.M. Hoffman

RECORDED RIGHT OF WAY NO. 33336

**THE DETROIT EDISON CO.**

PLAN SUBMITTED TO MICHIGAN PUBLIC UTILITIES COMMISSION  
FOR  
OVERHEAD LINE CROSSING

RX 1657

OVER GRAND TRUNK R R  
IN ECKLES ROAD  
CITY OF 1 3/4 MILES EAST OF SCODELLS SE 1/4 SECTION 1  
NALES TOWNSHIP T 6N R 15E ST CLAIR COUNTY

CIRCUITS					CONDUCTORS		
NUMBER	VOLTAGE	CYCLES	PHASE	USE	WIRES	SIZE	KIND
ONE	4800	60	1	DIST	2	#2	ACSR

POLES						
LOCATION	LENGTH	MATERIAL	CIRCUMFERENCE		DEPTH OF SETTING	KIND OF SETTING
			AT TOP	AT GROUND		
A-D	35'	SOUTHERN PINE	17"	27 1/2"	6'	CLAY SOIL
B-C	40'	"	23"	37"	6'	"
E	40'	"	17"	29"	6'	"
F	25'	WESTERN CEDAR	21"	30 1/2"	6'	"

**NOTE**  
MATERIALS SHALL BE AS NOTED IN THE DETROIT EDISON COMPANY'S STANDARD SPECIFICATIONS FOR OVERHEAD LINE CONSTRUCTION AT RAILROAD CROSSINGS ISSUED DECEMBER 23, 1935.

**PURPOSE OF LINE**  
EXTENSION OF RURAL DISTRIBUTION

DRAWN BY BBC DATE 11-16-36 CHECKED BY John H. H. 11-18-36

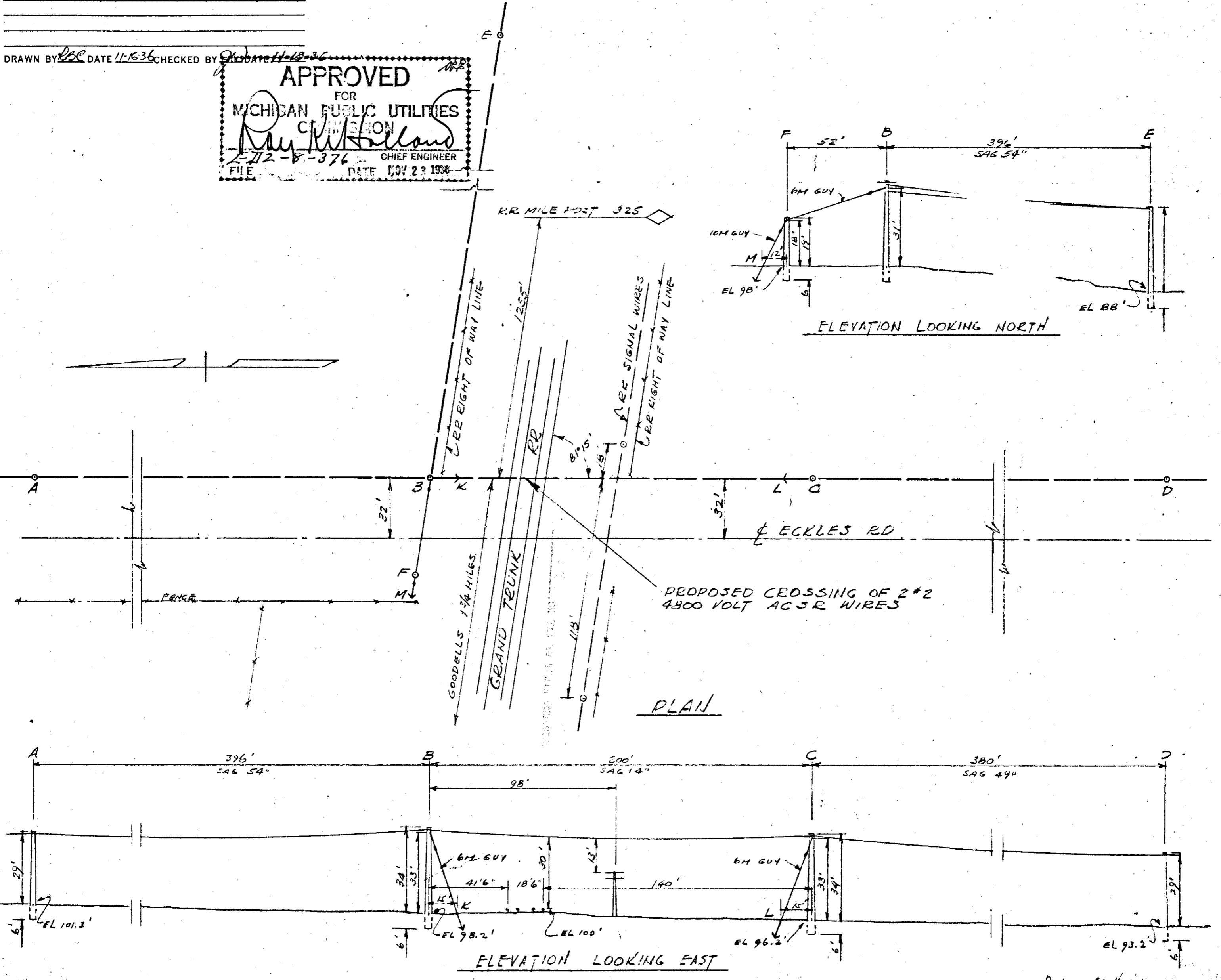
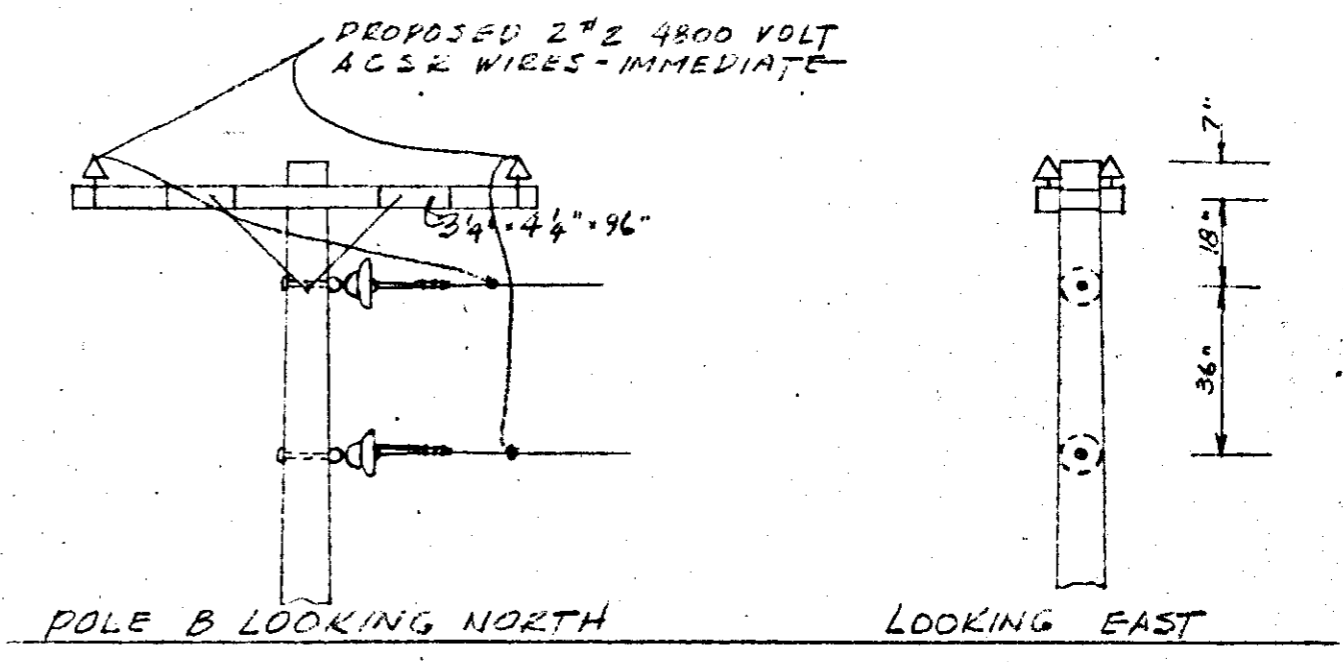
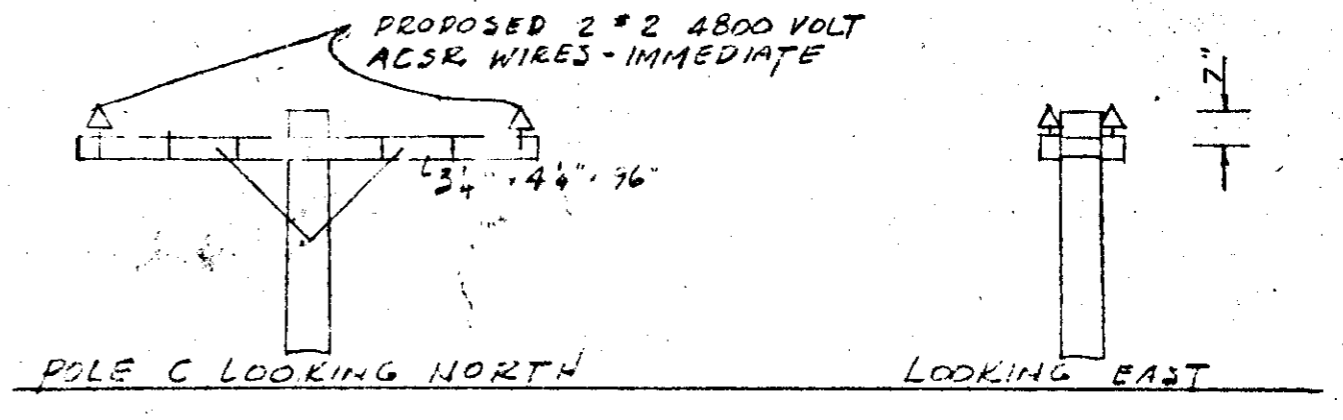
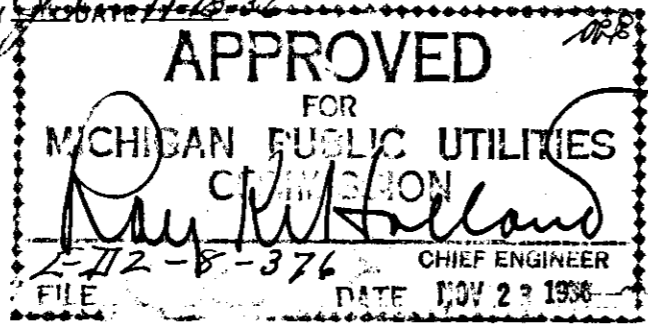

DRAFTING & SURVEYING BUREAU RX 1657

DAVIES - ST. MURIN

*Blender man*

RECORDED RIGHT OF WAY NO. 33336

R 33336

THIS INSTRUMENT IS A PUBLIC RECORD AND IS SUBJECT TO THE PUBLIC RECORD ACT OF CALIFORNIA, CHAPTER 10, SECTION 11600, AND TO THE PUBLIC RECORD ACT OF CALIFORNIA, CHAPTER 10, SECTION 11601.

RECORDED BY \_\_\_\_\_  
DATE \_\_\_\_\_

RECORDED BY \_\_\_\_\_  
DATE \_\_\_\_\_

RECORDED BY \_\_\_\_\_  
DATE \_\_\_\_\_

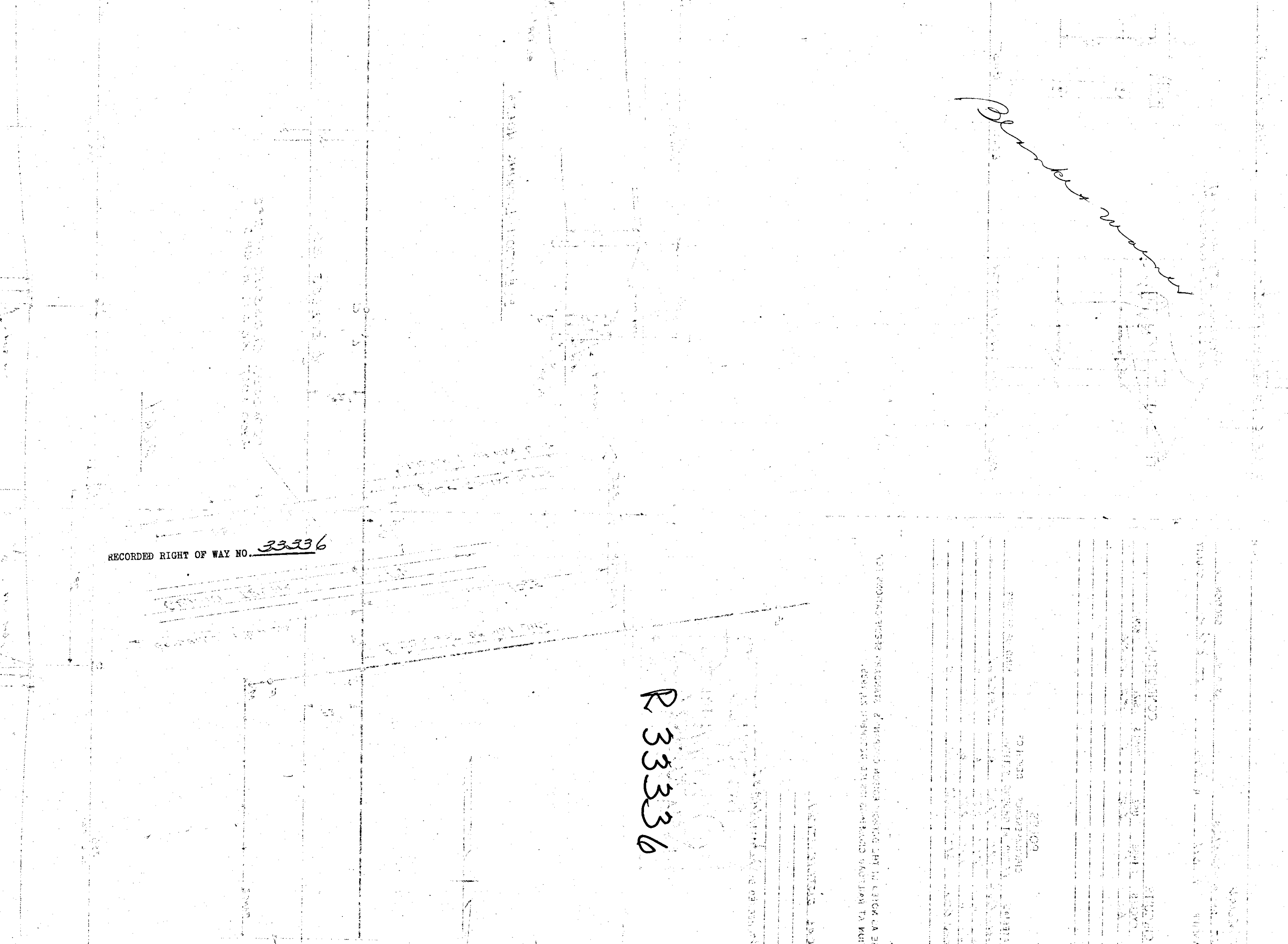

PROPOSED LINE CROSSING OVER GRAND TRUCK WESTERN R.R. EXISTING PERMIT NUMBER ED2-8-376  
IN ECKLES ROAD AND 1255' W OF MI POST 325. CITY OF 1 3/4 MILES E. OF GOODBELLS

SECTION 1 SE 1/4 TOWNSHIP WALES T 6N R 15E COUNTY ST. CLAIR

NOTES		CONDUCTORS				POLES			
MATERIALS SHALL BE AS NOTED IN THE CURRENT REVISION OF DETROIT EDISON COMPANY'S GENERAL SPECIFICATIONS FOR OVERHEAD LINE CONSTRUCTION AT RAILROAD CROSSINGS.		NUMBER	SIZE	KIND	VOLTAGE	LOCATION	LENGTH	CLASS	SET
ACTUAL FIELD DIMENSIONS MAY VARY SOMEWHAT FROM THOSE SHOWN, BUT THE REQUIREMENTS OF THE CURRENT REVISIONS OF ORDER NO'S. 1679 AND 1868 OF MICHIGAN PUBLIC SERVICE COMMISSION WILL BE COMPLIED WITH.		3	3/0	ACSR	4800	B & C	50	4	7'
<b>MINIMUM CLEARANCES</b>									
NEAREST POLE TO RAIL	SIDING	7 FT							
	MAIN LINE	12 FT							
WIRES OVER TRACKS	0 - 750 VOLTS	27 FT							
	750 - 15,000 VOLTS	28 FT							
	15,000 - 50,000 VOLTS	30 FT							
	50,000 - 120,000 VOLTS	33 FT							
WIRES OVER R R SIGNAL	0 - 750 VOLTS	2 FT							
	750 - 8,700 VOLTS	4 FT							
	8,700 - 50,000 VOLTS	6 FT							
	50,000 - 120,000 VOLTS	9 FT							

SPAN	SPAN LENGTH	LOWEST CONDUCTOR OVER R. R. TRACKS	STRINGING SAG AT 60° F	HEIGHT OF LOWEST CONDUCTOR OVER	
				R. R. TRACKS	R. R. SIGNAL WIRE
1	200'	#3/0 ACSR	1.4'	40.5'	22.8'

SAG TABLE 4  
RULING SPAN 275'  
FINAL SAG RATIO 1.43

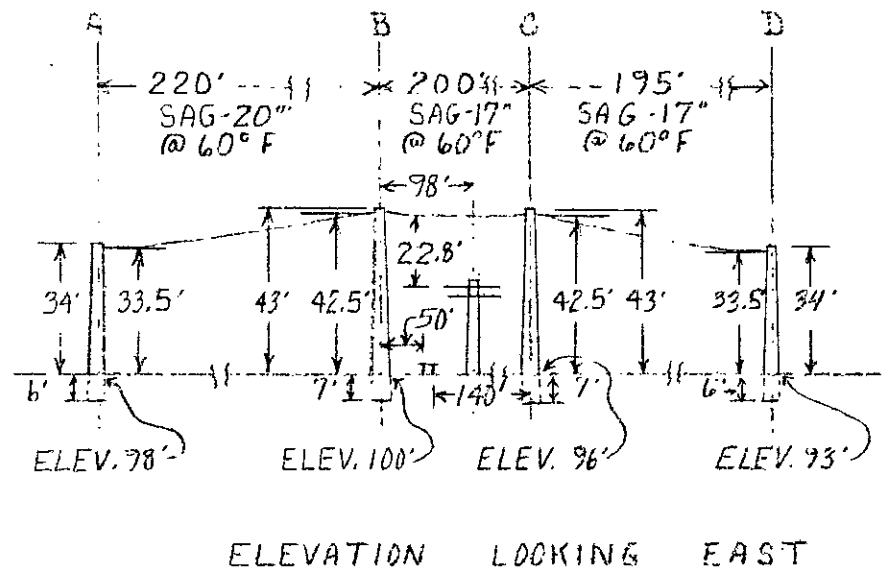
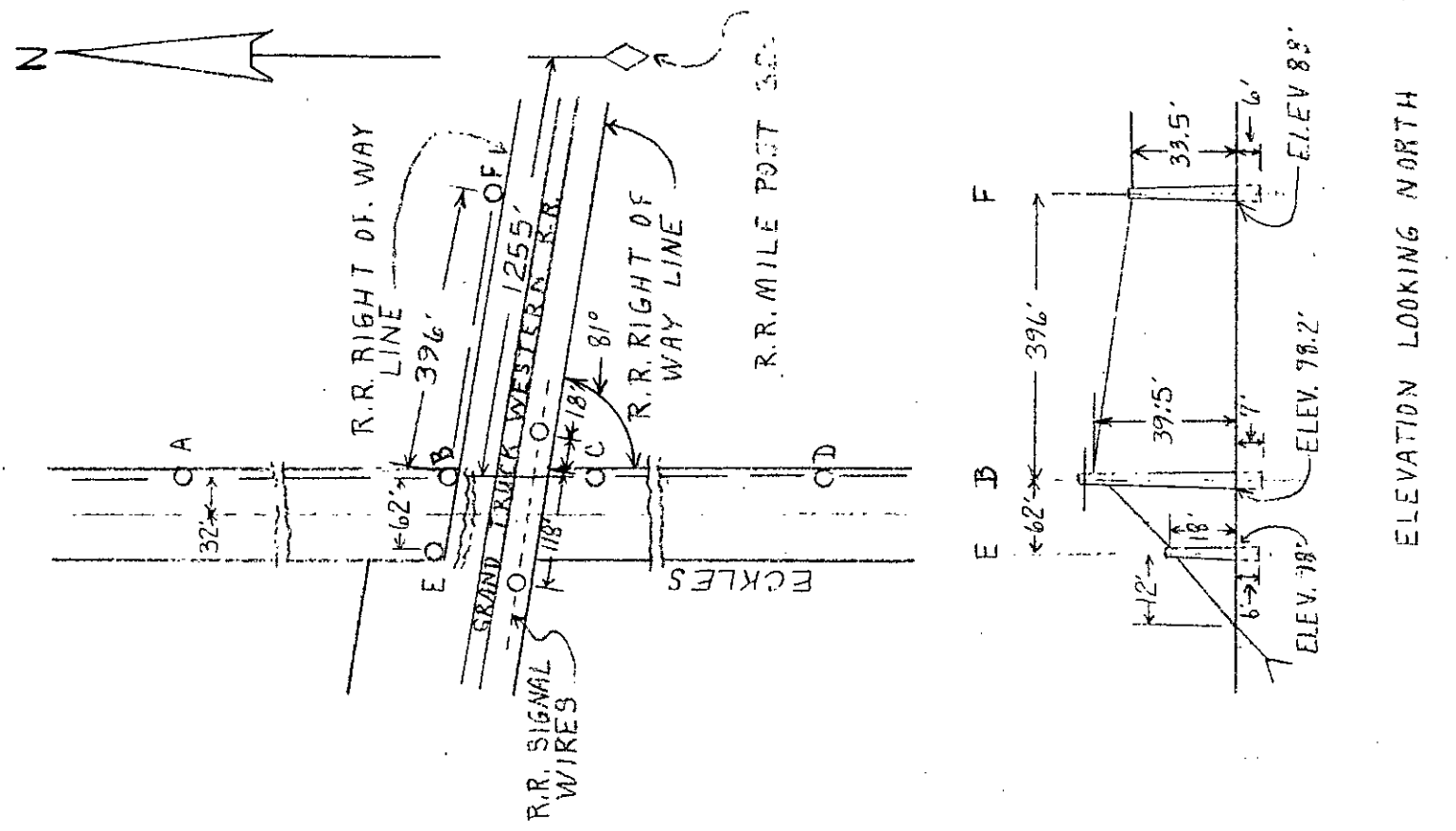
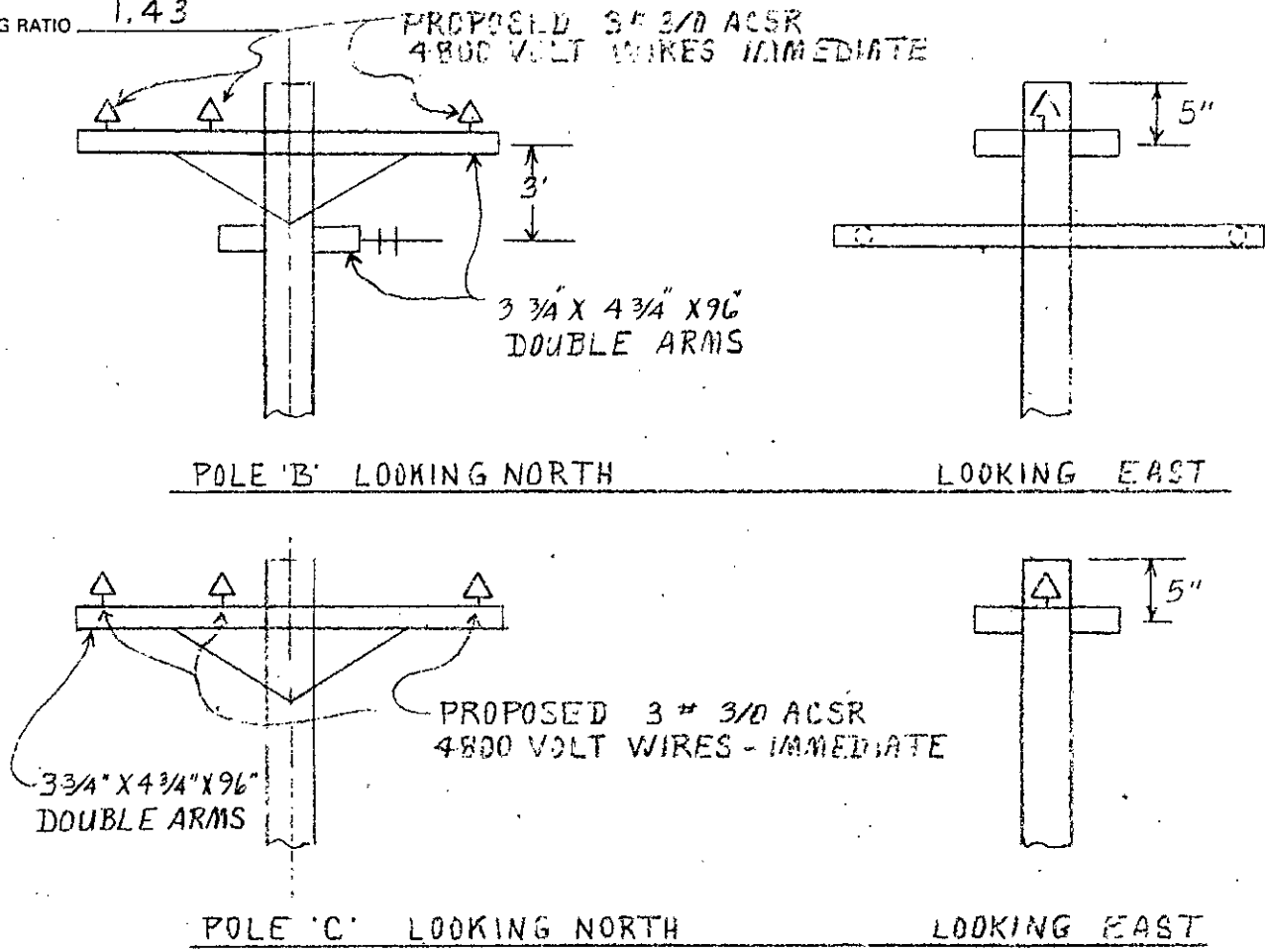

ELEVATION LOOKING NORTH



RECORDED RIGHT OF WAY NO. 23336

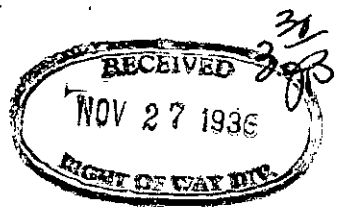

*Rec'd Ed*

*4079*

STATE OF MICHIGAN

Office of the Michigan Public Utilities Commission, } ss.

I, Clarke W. Brown, Secretary of the Michigan Public Utilities Commission

Do Hereby Certify, That I have compared the annexed copy of Permit ED2-8-376

*4079*

with the original

recorded in File ED2-8-376

and that it is a true and correct transcript therefrom, and of the whole of such original.

In Testimony Whereof, I have hereunto set my hand and affixed

the seal of the Commission, at Lansing, this 24th

day of November in the year of our Lord

one thousand nine hundred thirty-six.

*Clarke W. Brown*

Secretary Michigan Public Utilities Commission

RECORDED RIGHT OF WAY NO. \_\_\_\_\_

STATE OF MICHIGAN  
BEFORE MICHIGAN PUBLIC UTILITIES COMMISSION

Standard Railroad Wire-Crossing Permit No. ED2-8-376

In Re Application of **DETROIT EDISON COMPANY (Detroit)**

Pursuant to Act No. 171 of the Session Laws of 1893, as amended, application having been made to Michigan Public Utilities Commission by said

**Detroit Edison Company**

for permission to string wires across the tracks of the

**Grand Trunk Western Railroad Company**

and said

**Detroit Edison Company**

having conformed to the Commission's rules governing the filing of notices and issuing of permits for the construction of electrical lines and said railroad company having waived the right of notice and hearing provided for in said act

THEREFORE, It is ordered that said

**Detroit Edison Company**

be permitted to string the following described wires across the tracks of said railroad at the following described place:

In Wales Township, )	In Eckles Road, 1 $\frac{1}{2}$ miles east
St. Clair County )	of Goodells, in southeast quarter
Michigan: -- )	of Section 1, T-6-N, R-5-E, with:
)	2 - #2 A.C.S.R. wires
)	4800 volts.

as indicated on the attached plans, when, as and if approved.

At the point of crossing said wires shall be constructed in accordance with this Commission's rules and regulations.

Given under our hands and the Official Seal of this Commission at the City of Lansing, State of Michigan, this **24th** day of **November** A. D. 19**36**.

MICHIGAN PUBLIC UTILITIES COMMISSION

By

**William M. Smith**

Chairman,

**Emerson R. Boyles**

Commissioner,

**Ivan E. Hull**

Commissioner,

**Paul W. Voorhies**

Commissioner,

**Harold J. Waples**

Commissioner.

Countersigned

**Clarke W. Brown**

Secretary

RECORDED RIGHT OF WAY NO. 33336