

November 22, 1978

To: Records Center

From: Barbara Schmidt
Real Estate and Rights of Way Department

Subject: Distribution R/W crossing under the Consolidated Rail Corporation, City of Monroe, PC 230, RX-100D

The attached papers are for records center storage. Information about the completed transaction is shown in the following summary.

R.R. 1	R.R. INVOICE NO. M.P.S.C. NO. OR R.E. & R.W. NO. 9	Update Type 10	D.E.C.O. RECORDS CENTER FILE NO. 15	R.X. NO. OR MAP NO. 20	Facility 21	Agreement Date 23
09	00DE282	1		0100Δ	1	0:2287:8
Payment Frequency 28	Rental 29 33	OH-UG Code 34	Division 35	County 36	City or Township 38 44	Section 46
X	00000	2	6	07	MONROE	

PC
230

Location	
47	1W FIRST ST 150' W OF MACOMB ST
	50

Update Type Codes
 1 = New Agreement
 2 = Revised Agreement
 3 = Terminated Agreement

The Accounts Payable Department is requested to start or change the rental payment effective

Approved BAS

- cc: Accounts Payable
 Service Planning
 System Engineering
 Transmission & Distribution

RECORDED RIGHT OF WAY NO. 31994

Detroit

Edison

November 22, 1978

To: Records Center

From: Barbara Schmidt
Real Estate and Rights of Way Department

Subject: Distribution R/W crossing under the Consolidated Rail Corporation, City of Monroe, PC 230, RX-100D

The attached papers are for records center storage. Information about the completed transaction is shown in the following summary.

R.R. 1	R.R. INVOICE NO. M.P.S.C. NO. OR RE. & RW NO. 4	Update Type 3	DECO RECORDS CENTER FILE NO. 15	RX. NO. OR MAP NO. 25	Facility 21	Agreement Date 23
09	00DE282	1		0100Δ	1	022878
Payment Frequency 28	Rental 33	OH-UG Code 34	Division 35	County 36	City or Township 38	Section 39
<input checked="" type="checkbox"/>	00000	2	6	07	MONROE	PC 230

Location									
47	1M FIRST ST 150' W OF MACOMB ST								50

- Update Type Codes
 1 = New Agreement
 2 = Revised Agreement
 3 = Terminated Agreement

The Accounts Payable Department is requested to start or change the rental payment effective

Approved BAS

- cc: Accounts Payable
 Service Planning
 System Engineering
 Transmission & Distribution

RECORDED RIGHT OF WAY NO. 31994

24UG
8/76

CONSOLIDATED RAIL CORPORATION

1528 Walnut Street

PHILADELPHIA, PENNSYLVANIA 19104

Telephone: 215-893-6386

Assistant Vice President -

The Detroit Edison Company
2000 Second Avenue
Detroit, Michigan 48226

February 28, 1978
File: DE-282

Attention: John A. Haddow
Public Agency Coordinator
Real Estate & Right of Way

Gentlemen:

Reference is made to your letter dated September 1, 1977, attaching copies of your Drawing U3-2-8899 indicating your proposed installation of an underground crossing of one (1) concrete encasement containing four (4) 5-inch plastic ducts; one (1) duct to contain 4,800 volt power cables, one (1) duct to contain 13,200 volt power cables, with two (2) ducts to be used as spares, crossing under tracks of The Monroe Branch of Railroad, located at Valuation Station 1515+50+, at a point 950 feet west of Mile Post 1 and 0.64 of a mile west of the Station of Monroe, Monroe County, Michigan, within the confines of First Street.

We have no objections to the installation as mentioned above with the understanding that the abovementioned facilities will be installed in a safe and satisfactory manner and in accordance with the "General Conditions" hereto attached and made a part hereof. You will be required to contact: Mr. R. D. Lowery, Engineer of Construction, Chicago, Illinois Telephone: 312-236-7200 x2400 at least seven (7) working days prior to your desire to start of work to obtain his approval of your method of installation and related matters of this project, as well as inspection coordination. It is understood facility previously installed.

It is to be understood that this installation must be made in accordance with the approved plans and will conform with Railroad's current construction requirements.

To confirm your acceptance of these conditions, please have an authorized official of your Company indicate acceptance in the space provided on the duplicate of this letter and return it to this office. It is to be further understood that no work can be started until the signed copy of this letter is received by this office and you have obtained authorization from R. D. Lowery to proceed with construction.

Cancel and supersedes existing agreement, if any.

WJO/c

CONSOLIDATED RAIL CORPORATION

R. W. Orr
Assistant Vice President -

RECORDED RIGHT OF WAY NO. 31994

11/22/76

CONSOLIDATED RAIL CORPORATION

1528 Walnut Street

PHILADELPHIA, PENNSYLVANIA 19104

GENERAL CONDITIONS

1. Facilities must conform with all Federal, State and local laws, rules and regulations and will not be attached to any Railroad structure or appurtenance and will not otherwise be located on any private property of the Railroad.
2. In the event of any revision, renewal, addition or alteration of said facilities, prior approval of the Railroad must be secured.
3. Facilities will be installed, maintained, repaired and renewed by and at the sole risk, cost and expense of the OWNER.
4. If the Railroad deems it advisable during the progress of any work of construction, maintenance, repairs and renewals, alterations, adjustments or removal of the facilities and appurtenances of the OWNER, or in the event of emergency, to place watchmen, flagmen, inspectors or any other employees deemed necessary by Railroad for the protection of the property owned or in possession or control of the Railroad, or its employees, patrons, or licensees, the Railroad shall have the right to do so. The OWNER agrees to pay to Railroad the actual cost of material plus the current applicable overhead percentages for storage, handling, transportation, purchasing and other related material management expenses and the actual cost of labor plus the current applicable overhead percentages as developed and published by the Accounting Department of Railroad for fringe benefits, payroll taxes, administration, supervision, use of tools, machinery and other equipment, supplies, employers' liability insurance, public liability insurance, and other insurance, taxes and all other indirect expenses. It is to be understood that the aforementioned material and labor overhead charges are to be applied at the rates which are effective at the time of the performance of any work by employees of the Railroad on the said facilities. The OWNER agrees to pay such bills within thirty (30) days of the presentation thereof by Railroad. Failure of the Railroad to provide such watchmen, flagmen, inspectors or any other employees of Railroad, shall in no event be construed as in any manner or degree affecting any obligations of the OWNER as provided for elsewhere in these conditions.
5. All cost or expense resulting from any and all loss of life or property, or injury or damage to the person or property of any person, firm or corporation (including the parties hereto and their respective officers, agents and employees) and any and all claims, demands or actions for such loss, injury or damage, caused by or growing out of the presence or use, or the construction, maintenance, renewal, change or relocation and subsequent removal of said facilities and appurtenances herein referred to, caused by or from the joint or concurring negligence of both parties hereto shall be borne by them equally; if, however, any such loss, injury or damage shall be attributed to the negligence of one of the parties hereto, where solely or combined with the negligence of any other person or corporation not a party hereto, and without the concurring fault or negligence of the other party hereto, then such party hereto which by its fault, or negligence contributed thereto shall indemnify, protect and save harmless the other party hereto therefrom.
6. Upon abandonment of the facilities, the same shall be removed and the property of the Railroad shall be restored to good condition and this instrument shall become null and void, save and except only as to any liability accrued prior thereto.
7. All rights and obligations conferred hereby shall extend to the successors and assigns of the parties hereto, provided that the owner shall in no event transfer or assign its rights hereunder without the written consent of Railroad".

31994
76618

**Detroit
Edison**

2000 Second Avenue
Detroit, Michigan 48226
(313) 237-8000

February 10, 1978

Mr. R. W. Orr
Assistant Vice President-
Contracts
Consolidated Rail Corporation
8th Floor
1528 Walnut Street
Philadelphia, PA 19102

Dear Mr. Orr:

RE: DE-282
Underground Construction, Monroe Branch
First Street, Monroe Michigan

Those of us within the utility industry who request permits, licenses, etc., from the railroad, realize there is a three or four month period of time in which the railroad requires to process the requests through the various interested departments.

Unfortunately, not all projects can enjoy this amount of lead time. Such is the case of the subject underground crossing. This facility was requested by the City of Monroe and had to be completed within a specific time frame. As you can see by the enclosed letter they, the city, were quite active in the coordination with the local railroad representatives in securing the approval to construct the underground facilities.

Based on the letter of approval and assurance from the City, the project was completed. Therefore, it would seem, the specific requests in your letter of February 3, 1978 are no longer required.

In order to close our file, would you please issue the requested permits and remove the overhead lines crossing from your records.

Very truly yours,

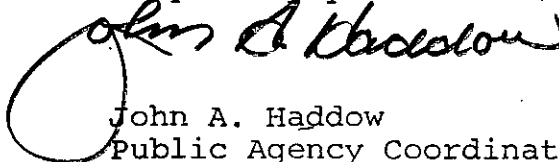

John A. Haddow
Public Agency Coordinator
Real Estate & Rights of Way

JAH/dm

RECORDED RIGHT OF WAY NO. 31994

CONRAIL

February 3, 1978
File: DE-282

Detroit Edison Company
2000 Second Avenue
Detroit, Michigan 48226

Attention: Mr. John A. Haddow
Public Agency Coordinator

Gentlemen:

We regret to inform you that your application dated September 1, 1977, for installation of four (4) 5-inch ducts in a concrete envelope for 4.8KV and 13.2KV cable crossings of the Monroe Branch at First Street in Monroe, Michigan, does not meet our specifications.

There was no data sheet submitted. The angle of the crossing is not shown, nor are pit location and design, with computations by a Registered Professional Engineer.

Timber sheeting under the track is not acceptable. Please resubmit new plans.

Very truly yours,

P. W. Orr
R. W. Orr
Assistant Vice President-
Contracts

RMM/c

1) CITY PERMIT - O.K.
2) R.R " VERBAL

RECORDED NIGHT COPY FILE NO. 31994

CITY OF MONROE
MICHIGAN

120 SOUTH MACOMB
48161

Mayor Milton "Pat" Munson

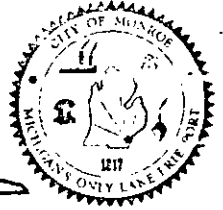

(313) 241-5975

October 12, 1977

Councilmen

George O. Imo
Samuel J. Mignano, Jr.
John S. Morris, Jr.
Richard C. Potter
Mark D. Smith
Joseph R. Stanifer

Detroit Edison Company
Wayne Division
8750 Telegraph Road
Taylor, Michigan 48180

Attention: Mr. Henry J. Fox
Senior Service Planner

Dear Mr. Fox:

Approval to tunnel under the Conrail tracks on First Street in Monroe was given verbally by Mr. Harla, Conrail engineer, October 11, 1977. A permit will follow through normal channels.

Conrail will be unable to have an inspector at the site and requested the utility take the responsibility of assuring proper construction. In the event the road bed is damaged, notify Mr. Masterson of Conrail in Monroe to avoid any vehicle accidents.

Sincerely yours,

Charles K. Sears, P.E.
Assistant City Director

CKS:bb

RECORDED FROM OCT 11 1977

31994

Detroit
Edison

2000 Second Avenue
Detroit, Michigan 48226
(313) 237-8000

March 15, 1978

Mr. R. W. Orr
Assistant Vice President-
Contracts
Consolidated Rail Corporation
Room 601 - Six Penn Center Plaza
Philadelphia, PA 19104

Dear Mr. Orr:

RE: Wire Crossing Permit ED2-8-3377
Dated 4/23/54
Detroit Edison RX-100D

As of this date all wires and poles are removed in
Span B-C.

The location is in First Street approximately 150' West of
Macomb Street, City of Monroe, Section PC-230, Township
of Monroe, County of Monroe.

Please acknowledge this letter by your signature below,
and return the copy to us for our files.

Very truly yours,

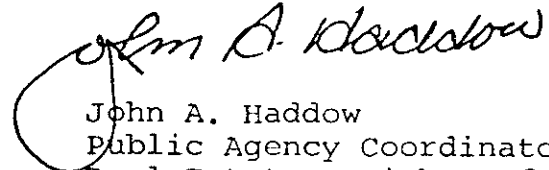

John A. Haddow
Public Agency Coordinator
Real Estate & Rights of Way

JAH/dm

CONSOLIDATED RAIL CORPORATION

RECORDED RIGHT OF WAY NO. 31994

Submit One (1) Copy for each Span to
Real Estate and Rights of Way Dept.

THE DETROIT EDISON COMPANY

RAILROAD CROSSING REMOVAL

RX 100D

Span B-C

M.P.S.C. Permit and Date ED2-8-3377 4-23-54

Railroad: New York Central

Location: In First St. Approx. 150' West of Macomb St., City of Monroe,
Section PC230, Township of Monroe, County of Monroe

Reason: All Wires and Poles removed.

System Engineering Dept.

Date 2/1/78

By F. M. Hoffman *FMA*

RECORDED RIGHT OF WAY NO.

31994

APR 22 1954
SECRETARY'S OFFICE

THE DETROIT EDISON COMPANY UTILITIES

2000 SECOND AVENUE
DETROIT 26, MICHIGAN

April 21, 1954

Tel. _____ Gas _____
Elec. _____ Adm. _____
Fund A _____ Fund V _____
In _____

Michigan Public Service Commission
Lansing 13, Michigan

Gentlemen:

The Detroit Edison Company, Detroit, Michigan, hereby makes application for authority to string the following wires over the tracks of the ~~New York~~ Central (LS & MS Division) R.R. in the City of Monroe, Monroe Twp., Monroe County, Michigan.

300 wpx - 4800 volt wires, 2#6 TBWP - street lighting and one 5/16" copperweld guy wire over the tracks of the N.Y.C.R.R. located in First Street at a point approximately 150' west of Macomb Street.

Foreign Wires

- 2#8 city signal wires
- #14 twisted pair MBT telephone wire

The proposed wire crossing will be constructed in accordance with specifications of the Michigan Public Service Commission and the construction standards of The Detroit Edison Company, approved by the Michigan Public Service Commission on July 19, 1939, File ED 2-9.01.

- Enclosed is a waiver of hearing granted by the Railroad Company.
- Waiver of hearing by the Railroad Company is covered by blanket waiver.
- This application covers reconstruction of existing crossing and will cancel and supersede wire crossing permit No. ED 2-8-1721 dated 5-28-46
- This is a new crossing.

Reference number of construction drawing is RX- 100D

Yours very truly,

L. G. Hedden
~~XXXXXXXXXXXX~~
~~XXXXXXXXXXXX~~

L. G. Hedden
Supervisor

Rights-of-Way Department

Permit No. ED2-8-3377

Date 4-23-54

By *J. M. [Signature]*

✓ Check in square indicates statement applicable.

1954 APR 23 11 00 AM '54

RECEIVED PERMITTING DIVISION APR 23 1954 31994

THE DETROIT EDISON COMPANY

2000 SECOND AVENUE
DETROIT 26, MICHIGAN

PUBLIC UTILITIES	
Tel.	Gas
.....	Adm.
JUN 9 1954	
F and A.....	R and V.....
File

RECEIVED
MICHIGAN PUBLIC SERVICE
COMMISSION

JUN 7 - 1954

SECRETARY'S OFFICE

Permit No. ED 2-8-3377

Michigan Public Service Commission
Lansing 13, Michigan

Gentlemen:

I, Lyman G. Hedden, Supervisor, Rights of Way Procurement
of The Detroit Edison Company, Detroit, Michigan, hereby certify that the
wire crossing, covered by Wire Crossing Permit No. ED 2-8-3377,
issued April 23, 1954, has been constructed in accordance with
specifications of the Michigan Public Service Commission and construction
standards of The Detroit Edison Company, approved by Michigan Public
Service Commission on July 19, 1939, file ED 2-9.01, and that this crossing
will be maintained as provided in such specifications and construction
standards.

Yours very truly,

Lyman G. Hedden

RX No. 100 D
Location City of Monroe
Monroe Township
Monroe County
Railroad New York Central
(L.S. & M.S. Division)
Railroad.

Subscribed and sworn to before me this
4th day of June, 1954.
Joan W. Bance
Notary Public, Wayne
County, Michigan.
My Commission expires April 16, 1957

In 1st St. at a point approx. 150'
W. of Macomb St.

RECEIVED
MICHIGAN PUBLIC SERVICE
COMMISSION
DEPARTMENT
1954 JUN 14 PM 2 41

RECORDED RIGHT OF WAY NO.

31994

PROPOSED LINE CROSSING OVER NEW RR CENTRAL (LS & MS) RR EXISTING PERMIT NUMBER ED 2-8-1721
 IN FIRST ST. APPROX. 150' WEST OF MACOMB ST. CITY OF MONROE
 SECTION PC 230 TOWNSHIP MONROE T R COUNTY MONROE

NOTES

MATERIALS SHALL BE AS NOTED IN THE DETROIT EDISON COMPANY'S STANDARD SPECIFICATIONS FOR OVERHEAD LINE CONSTRUCTION AT RAILROAD CROSSINGS DATED MARCH 1947.

ACTUAL FIELD DIMENSIONS MAY VARY SOMEWHAT FROM THOSE SHOWN BUT THE REQUIREMENTS OF ORDER NO. 1879 OF MICHIGAN PUBLIC SERVICE COMMISSION, AS REVISED JAN. 1, 1944, WILL BE COMPLIED WITH.

MINIMUM CLEARANCES

NEAREST POLE TO RAIL	SIDING	7 FT.
	MAIN LINE	12 FT.
WIRES OVER TRACKS	0 - 500 VOLTS	27 FT.
	500 - 7500 VOLTS	28 FT.
	24000 VOLTS	30 FT.
WIRES OVER R. R. SIGNAL	0 - 500 VOLTS	2 FT.
	500 - 7500 VOLTS	4 FT.
	24000 VOLTS	6 FT.

CONDUCTORS				POLES			
NUMBER	SIZE	KIND	VOLTAGE	LOCATION	LENGTH	CLASS	TYPE
3	0	W.P.X.	4800	A	55	2	W. CEDAR
2	6	T.B.W.P.	ST. LTG.	B	55	2	"
1	5/16	CW	GUY	C	50	3	"
				D	55	3	"
				MST #833	30	4	"

DRAWN BY C.D.M. ENGINEERING DIVISION DATE 9-16-53
 ESTIMATOR W. BONLING OVERHEAD LINES DEPT. MONROE

DE FORM 5E 32

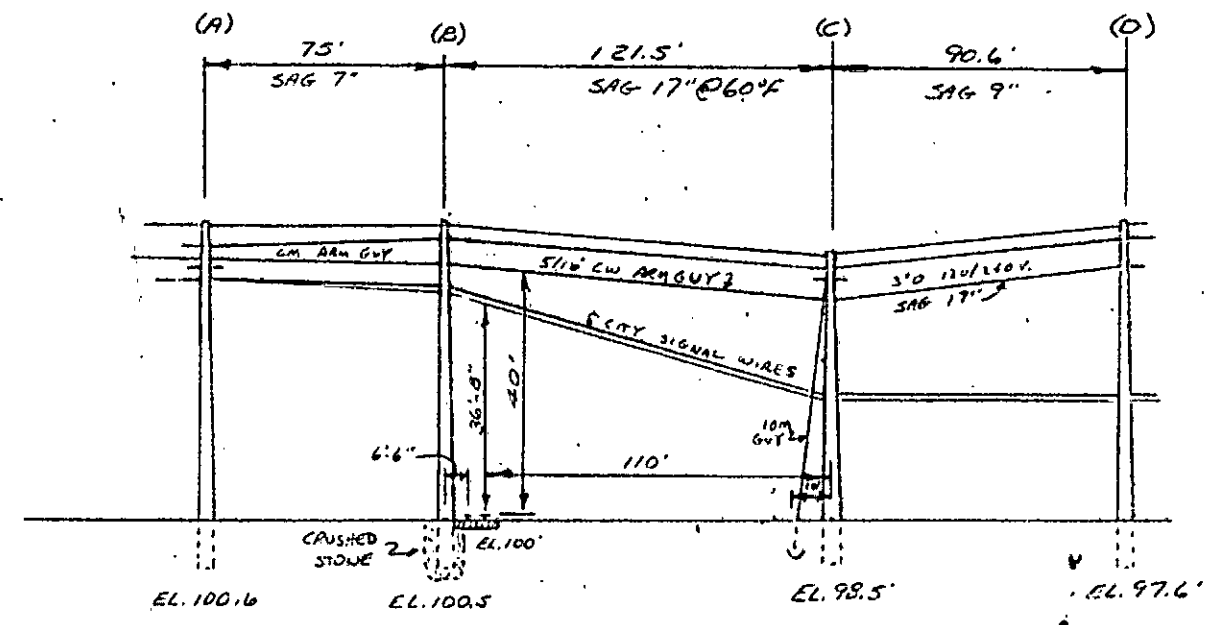
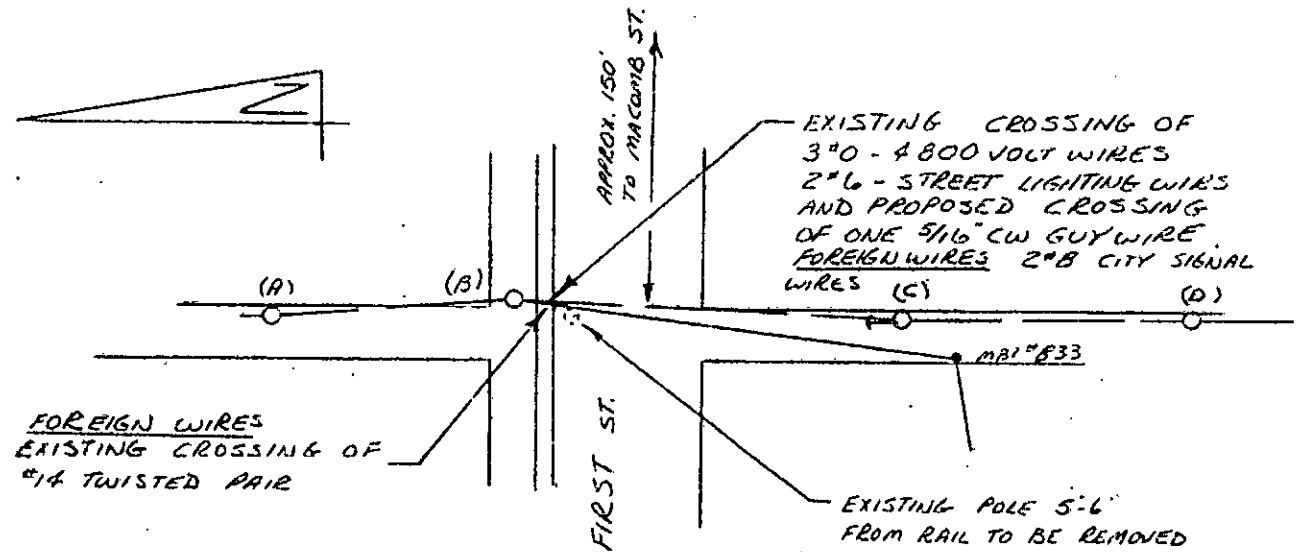

ELEVATION LOOKING EAST

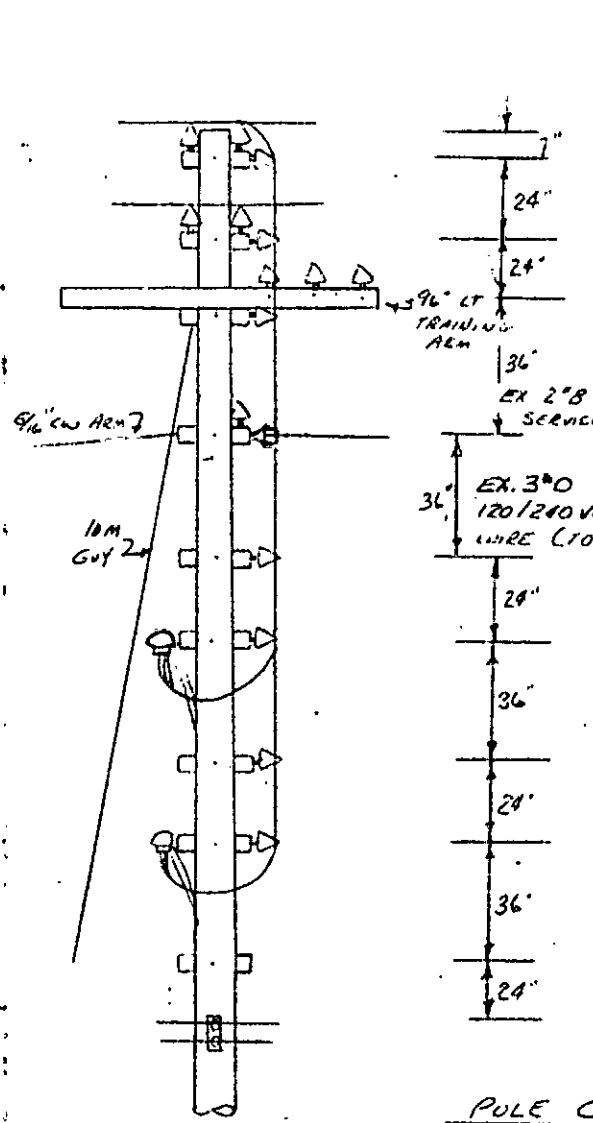

LOOKING EAST

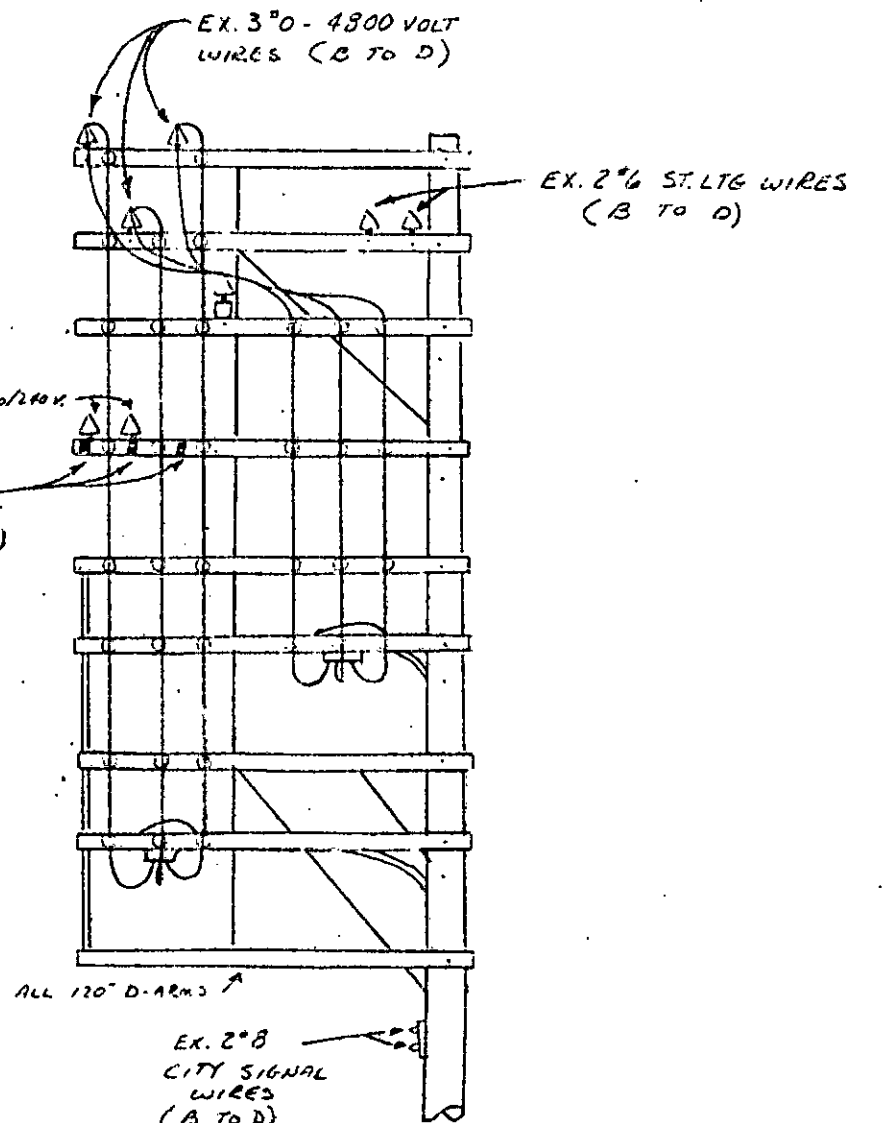

LOOKING NORTH

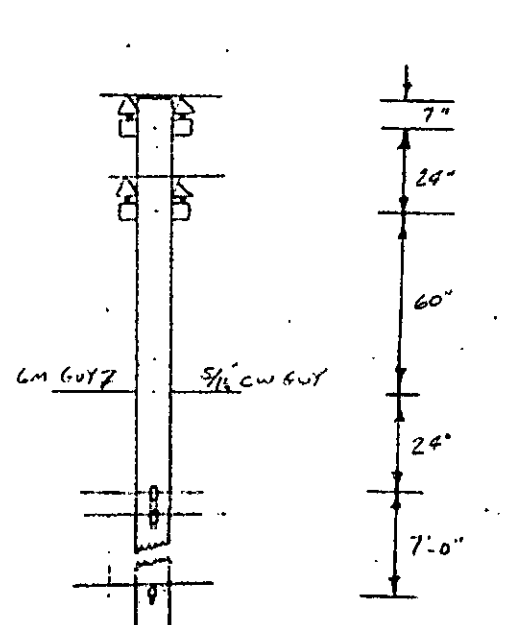

LOOKING EAST

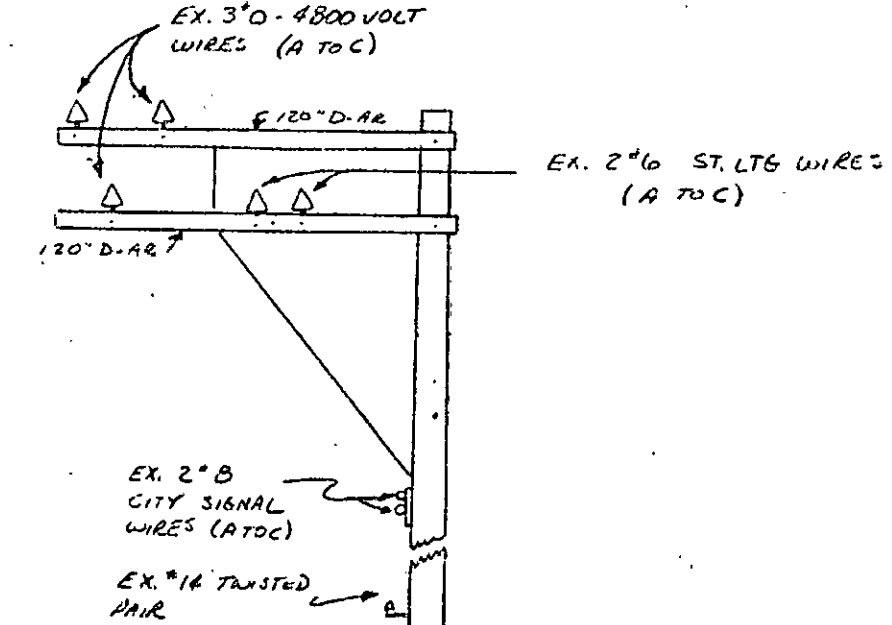

LOOKING NORTH

RECORDED RIGHT OF WAY NO. 31994

CONRAIL



File: DE-282

1528 Walnut Street
Room 801
Philadelphia, Pa. 19104

Detroit Edison Company
2000 Second Avenue
Detroit, Michigan 48226

Attention: Mr. John A. Haddow, Public Agency Coordinator

Gentlemen:

We had a call October 5, 1977 from Mr. Don French, City Manager of the City of Monroe, Michigan in regard to your application dated September 1, 1977 for crossing the Monroe Branch of our railroad at Valuation Station 1515+50 (on First Street, Monroe) with four (4) 5" ducts encased in a concrete envelope to contain 4.8 KV and 13.2 KV cables.

Mr. French stated that he hoped this project would be expedited and said that he would inform you to get in touch with our Mr. Mason to discuss what problems there might be.

Our Contract Bureau has not been able to locate the agreement you mentioned in your letter of September 1st, and expect that the June 4, 1954 date is that of a supplement to an original agreement of another date.

*7/07
SO*

Your drawing states that the details of the box tunnel will be found on drawing #U1-2-11858, but the drawing was not submitted with your application.

Our structural people must have these drawings in order to ascertain whether the track loading can be handled satisfactorily.

I am sure you are aware that you did not allow enough lead time for this application, but if you will furnish either a copy of the original agreement covering the aerial crossing or give us a date to use for a base of operation, and if you will forward the missing plan plus a required data sheet, we will proceed to expedite your application.

Sincerely,

R. W. Orr
R. W. Orr
Assistant Vice President-Contracts

R. MASON

RMM:das
10341 (215) 893-6401

RX-100D

RECORDED RIGHT OF WAY NO.

**Detroit
Edison**

2000 Second Avenue
Detroit, Michigan 48226
(313) 237-8000

October 6, 1977

Mr. R. W. Orr
Assistant Vice President-Contracts
Consolidated Rail Corporation
1528 Walnut Street
Eighth Floor
Philadelphia, PA 19104

ATTENTION: Dick Mason

Dear Mr. Orr:

RE: New York Central Permit No. ED 2-8-3377
Dated June 4, 1954
Detroit Edison RX-100D

Per our phone conversation of October 6, 1977, I am enclosing additional copies of the conduit drawing of the subject railroad crossing.

It appears that the original crossing date was May 28, 1946.

I would appreciate your expedience in this matter.

Very truly yours,

Joan McLair for

John A. Haddow
Public Agency Coordinator
Real Estate & Rights of Way

JAH/dm
Enc.

RECORDED 11/13/77 10:11 AM

**Detroit
Edison**

2000 Second Avenue
Detroit, Michigan 48226
(313) 237-8000

September 1, 1977

Mr. R. W. Orr
Assistant Vice President - Contracts
Consolidated Rail Corporation
Room 601 - Six Penn Center Plaza
Philadelphia, Pennsylvania 19104

Con. Rail

DE-282

Dear Mr. Orr:

RE: New York Central Permit No. ED 2-8-3377
Dated June 4, 1954 —
Detroit Edison RX-100D

We request your permission to install and maintain 4-5" ducts in a concrete envelope for 4.8KV and 13.2KV cables as per Drawing U3-2-8899.

We will be removing the overhead wires and poles to allow construction of new City Hall.

The location is in First Street, east of Washington Street in the City of Monroe, Monroe County.

Accordingly, will you please provide us with the necessary underground permits to complete the construction. Due to a construction deadline, could we please have the necessary permits by October.

Very truly yours,

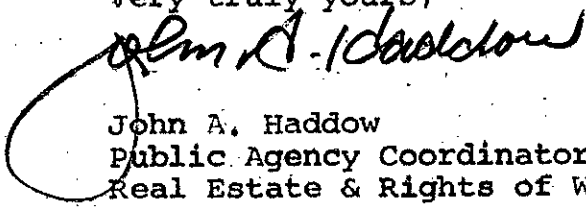
John A. Hadow
Public Agency Coordinator
Real Estate & Rights of Way

JAH/dm
Enc.

*Rx-100
Penn
Central*

PLEASE SECURE RIGHT OF WAY AS FOLLOWS:

DATE August 9, 1977

LOCATION Consolidated Railroad Corporation

APPLICATION NO. _____

First Street, east of Washington

DEPT. ORDER NO. _____

CITY OR VILLAGE Monroe

O. F. W. NO. _____

TOWNSHIP _____ COUNTY Monroe

BUDGET ITEM NO. _____

DATE BY WHICH RIGHT OF WAY IS WANTED October 3, 1977

INQUIRY NO. _____

THIS R/W IS _____ % OF TOTAL PROJECT NO. _____ ACCUM. _____ %.

JOINT RIGHT OF WAY REQUIRED YES NO

NOTE: Identify on print or sketch the subdivisions as to section location and liber and page.

KIND AND DESCRIPTION OF RIGHT OF WAY REQUESTED Uninstall and maintain 4-5" ducts in a concrete envelope for 4.8KV and 13.2KV cables as per Drawing U3-2-8899.

PURPOSE OF RIGHT OF WAY To remove overhead wires and poles. To allow construction of new City Hall.

SIGNED Louis P. Belletini
L. P. Belletini, Supvr.
Eng., Plng & Layout Group
OFFICE dt

DIVISION SERVICES
DEPARTMENT

REPORT OF REAL ESTATE AND RIGHTS OF WAY DEPT.

RECORDED RIGHT OF WAY NO. 31994

PERMITS IN RECORD CENTER _____ R.E. & R/W DEPT. FILE _____ GRANTOR _____

NO. OF PERMITS _____ NO. OF STRUCTURES _____ NO. OF MILES _____ PERMITS TO MBT _____

DATE _____ SIGNED _____

*LOG IN
8/25/77*

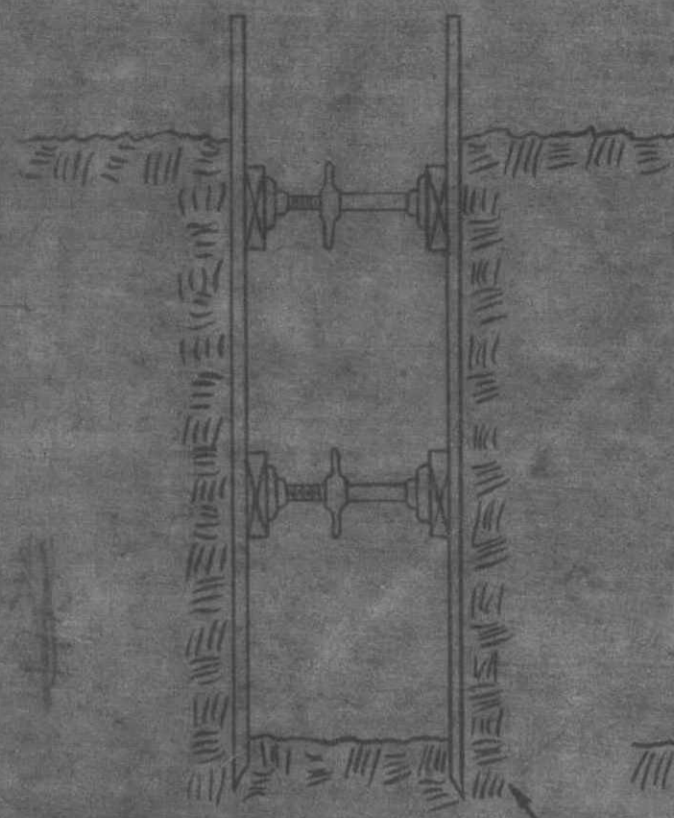

CROSS-SECTION OF TRENCH

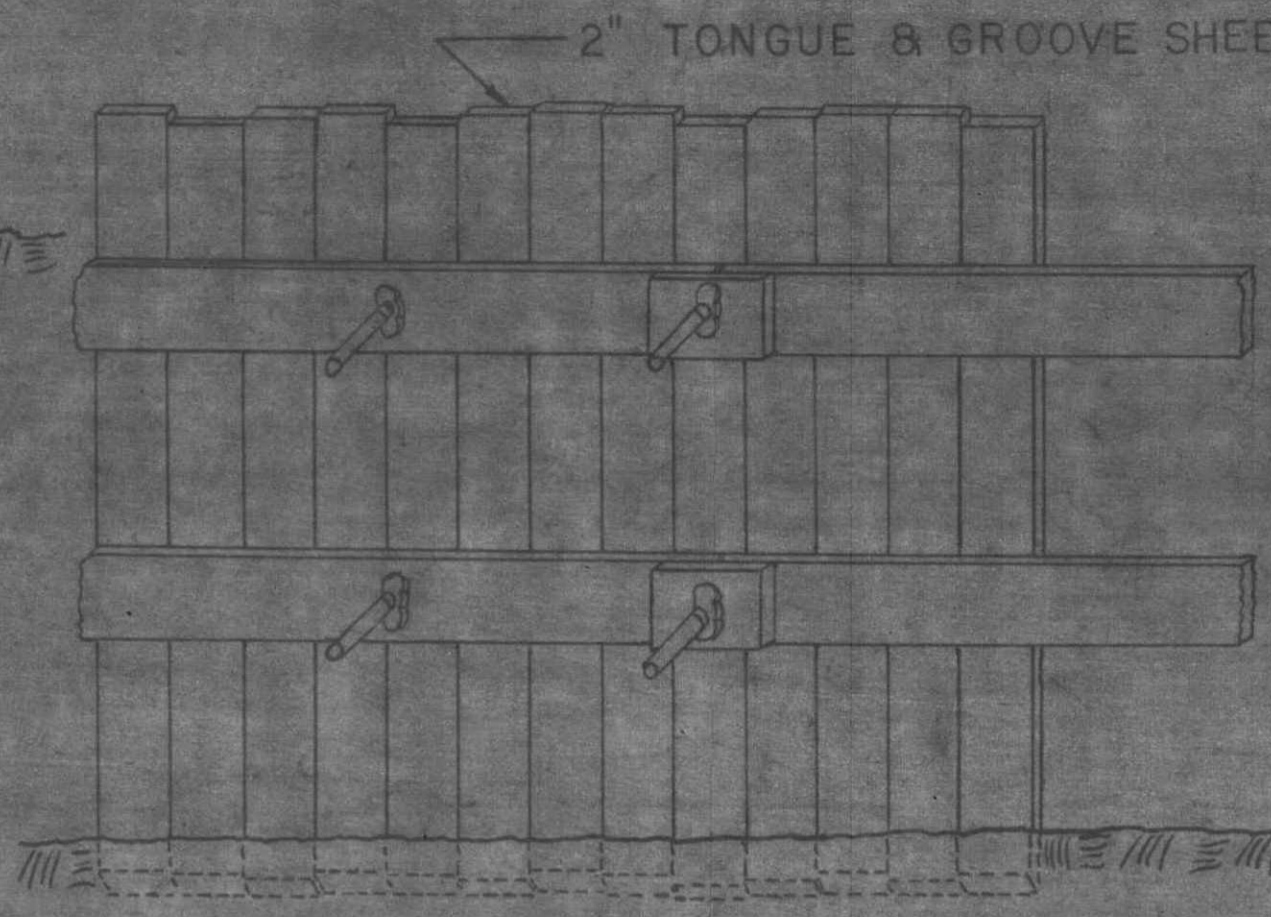

CUT-AWAY VIEW SHOWING TIGHT SHEETING IN PROCESS OF INSTALLATION

ENDS OF SHEETING BELOW BOTTOM OF EXCAVATION AT ALL TIMES
0'-0" TO 1'-0" AS REQUESTED BY ENGINEER

TIGHT SHEETING

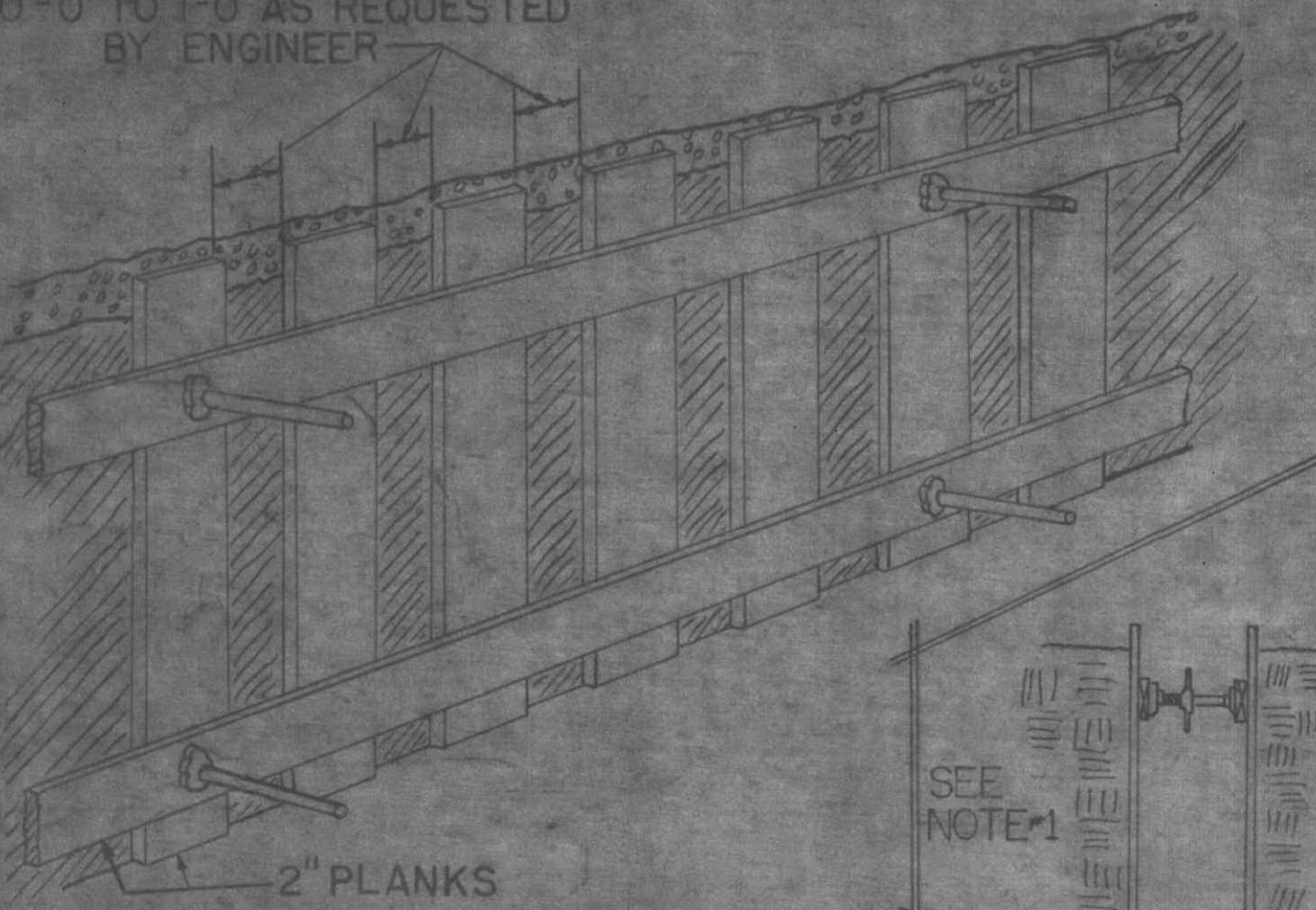

2" PLANKS
VERTICAL BRACING

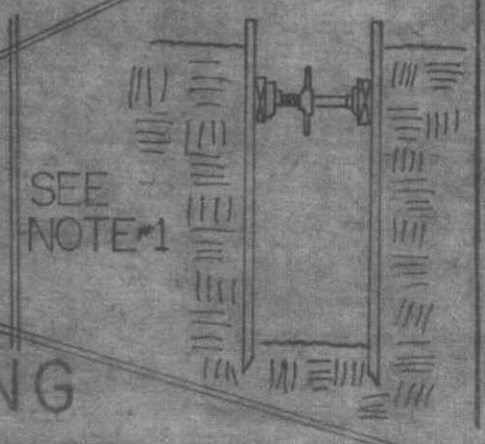

SEE NOTE #1

NOTE #1 WHEN NECESSARY, VERTICAL BRACING MAY BE REQUIRED TO BE DRIVEN BELOW TRENCH BOTTOM, THUS ELIMINATING LOWER WALER.

3" X 6" ROUGH CUT MAPLE PLANKS
BACKFILL OVER CONDUIT TO BE 1:10 DRY MIX TAMPED INTO PLACE
DO NOT EXCAVATE MORE THAN 1' AHEAD OF BOXING

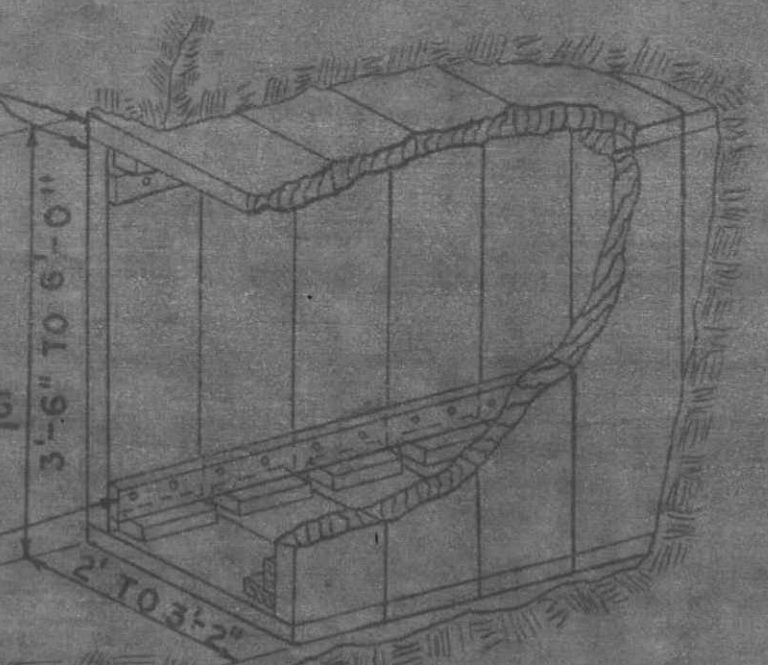

CUT-AWAY VIEW SHOWING BOXING IN PLACE

12' LONG TWO BY FOURS TO BE SPIKED IN EACH CORNER JOINTS TO COME AT MIDDLE OF PLANK

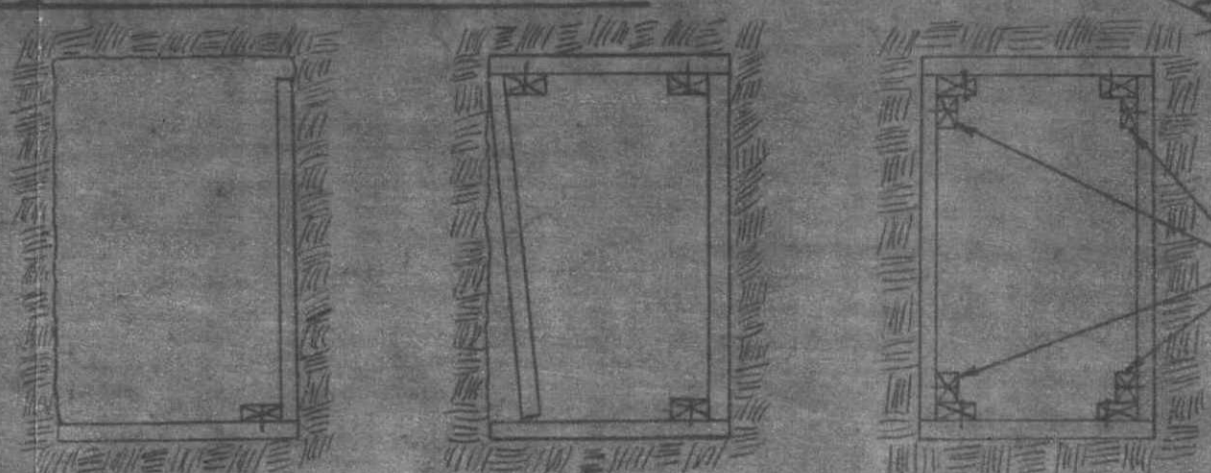

STEPS IN INSTALLATION OF BOXING

BOX TUNNEL FOR EXCAVATING UNDER RAILROAD TRACKS

TWO BY FOURS SPIKED TO PLANKS

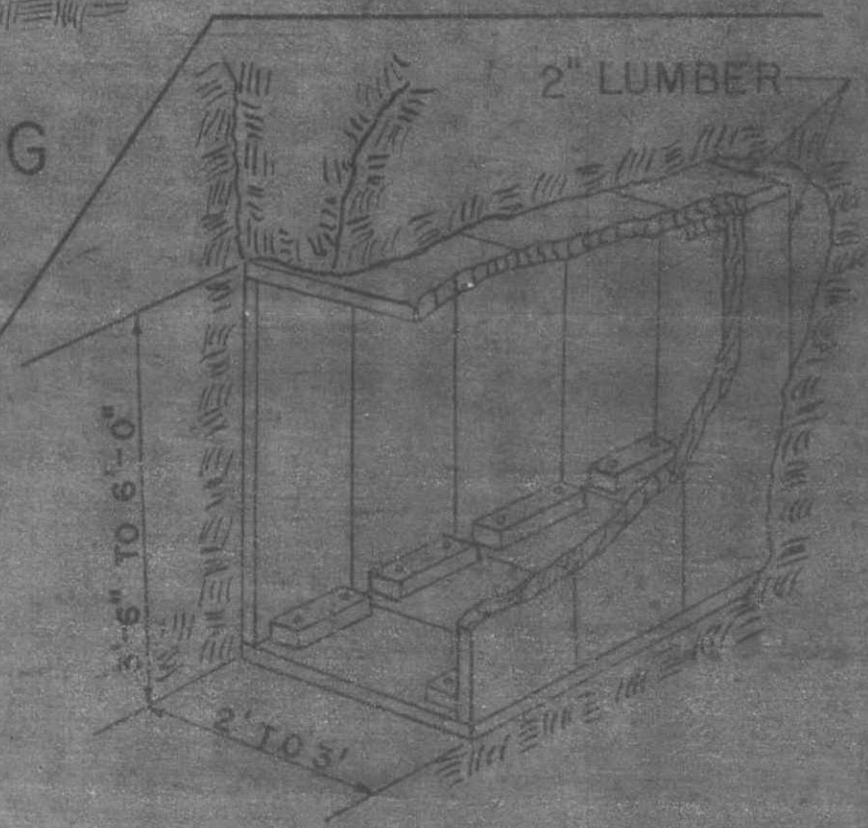

2" LUMBER

3'-6" TO 6'-0"

2' TO 3'

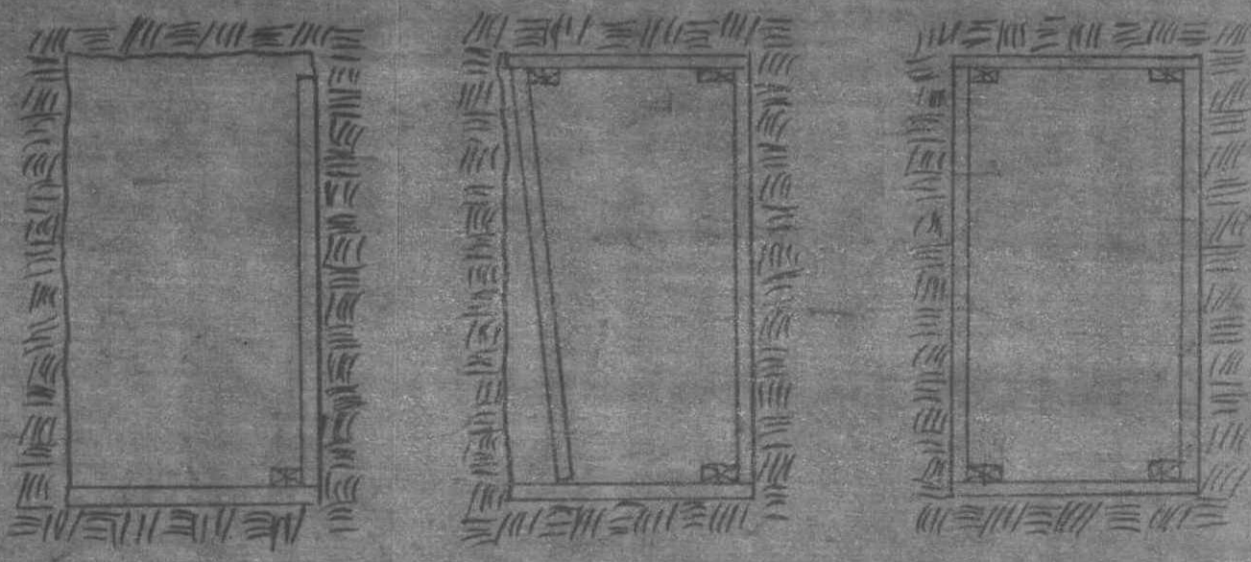

STEPS IN INSTALLATION OF BOXING

BOX TUNNEL FOR EXCAVATION IN UNSTABLE SOIL & BELOW D.S.R. TRACKS

REV. A) ADDED NOTE #1
ABOUT VERTICAL BRACING

SUPERSEDES - UI-2-1185-A & -UI-1-1500-A

TRACED BY SCHMALTZ 12-26-51

DRAW	M. OUELLY	2-26-51
OK	SCHLACKER	2-6-51
APP	CLARK	2-6-51

TIGHT SHEETING BOXING AND VERTICAL BRACING FOR EXCAVATIONS

THE DETROIT EDISON COMPANY
U.G.L. DEPT.
SCALE NONE

REV. A

UI-2-1185

RECORDED RIGHT OF WAY NO. 31994



FIRST ST. 66' WD

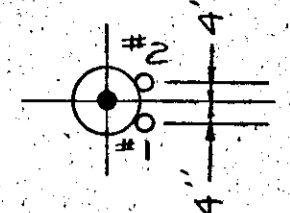

C.P. TO BE SET
INSTALL 2-5" SWPS.

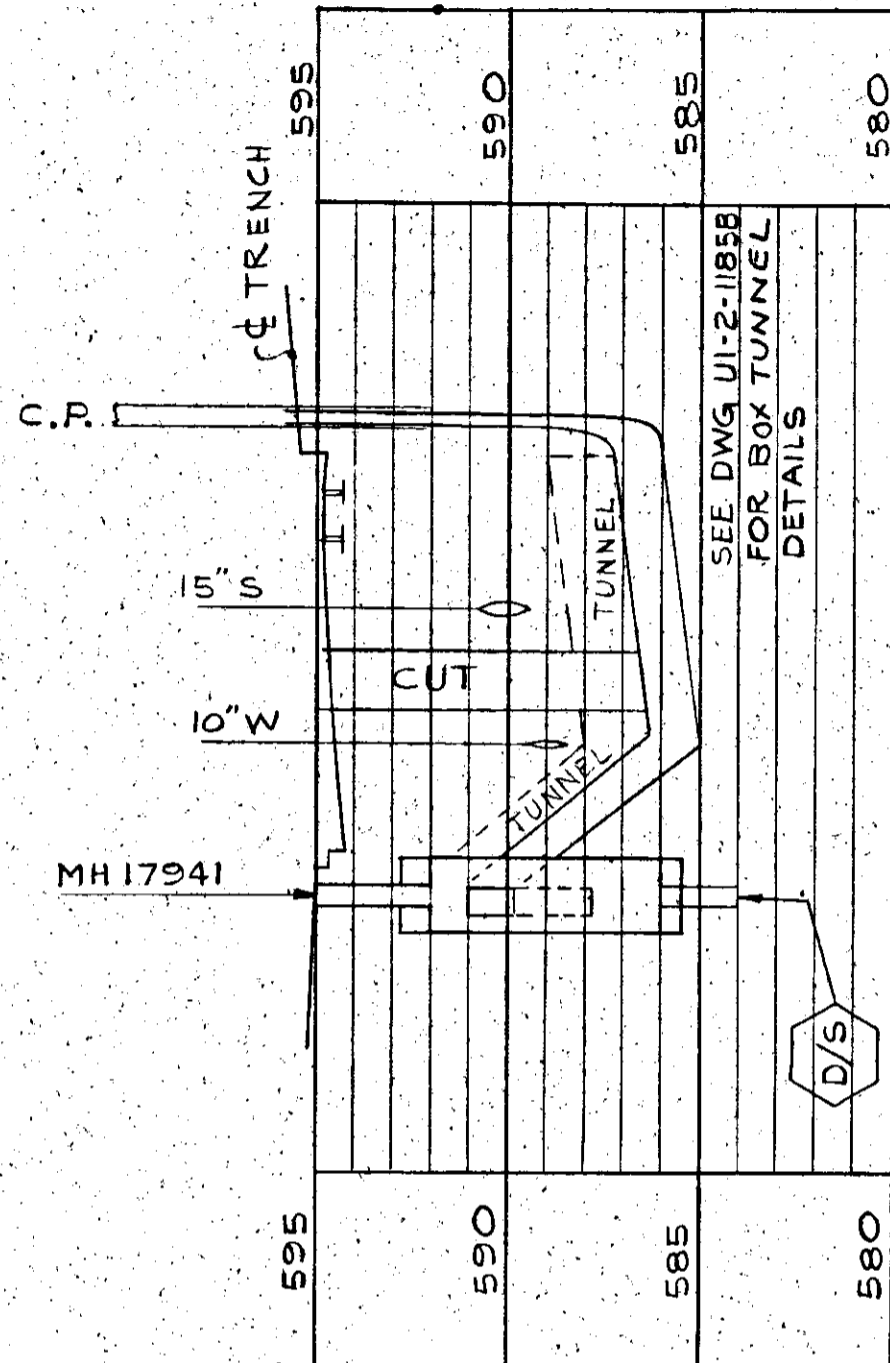

LOOKING WEST

SCALE
HORIZ 1"=20'
VERT 1"=5'

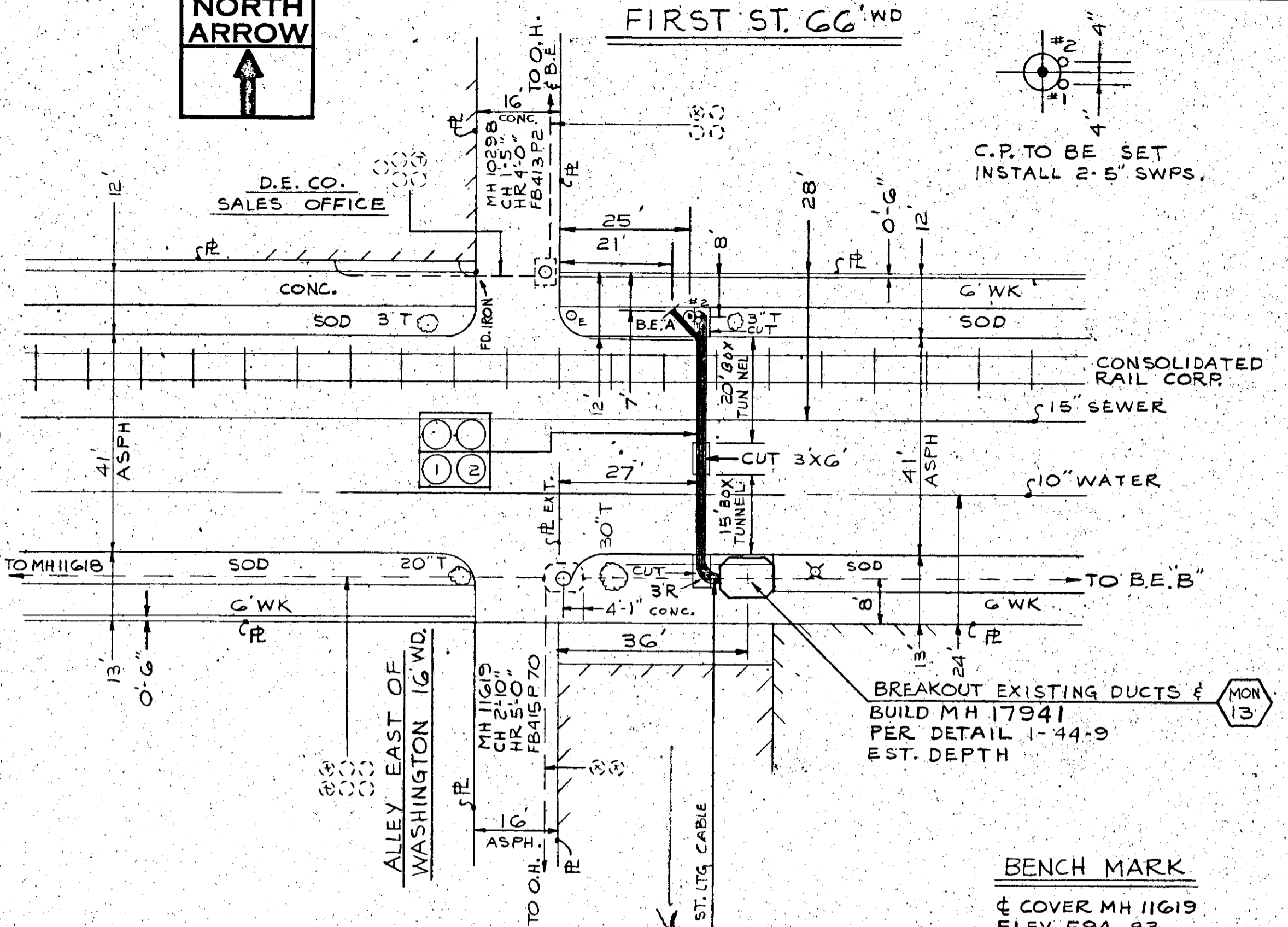

BENCH MARK

¢ COVER MH 11619
ELEV. 594.83

PERMITS REQ

CITY OF MONROE
CONSOLIDATED RAILROAD

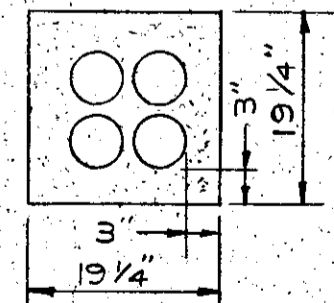

TYPICAL CROSS-SECTION

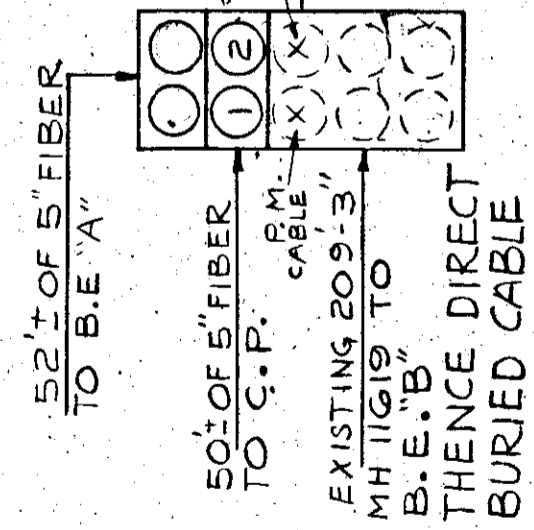

OFW 7JA7AB/MOI
JOB 77-067

FRONT STREET SUB.

REVISION	REVISION	REFERENCE	DRAWN	J.C.R. 8-5-77	FIRST ST., EAST OF WASHINGTON
			OK	APB 8-6-77	INSTALL MANHOLE & 5" CONDUIT TO ALLOW REMOVAL OF OVERHEAD
			APPROVED		CITY OF MONROE MONROE CO.

THE DETROIT EDISON COMPANY

SCALE 1"=20' PRINTED MON 13 U3-2-8899

RECORDED RIGHT OF WAY NO. 31994