

STATE OF MICHIGAN
BEFORE MICHIGAN PUBLIC UTILITIES COMMISSION
SERVICE

Standard Railroad Wire-Crossing Permit No. EDE-8-908

In Re Application of **Detroit Edison Company**

Pursuant to Act No. 171 of the Session Laws of 1893, as amended, application having been made to Michigan Public Utilities Commission by said **Detroit Edison Company**
Service

for permission to string wires across the tracks of the **Detroit Terminal Railroad**

and said **Detroit Edison Company**

having conformed to the Commission's rules governing the filing of notices and issuing of permits for the construction of electrical lines and said railroad company having waived the right of notice and hearing provided for in said act

THEREFORE, It is ordered that said **Detroit Edison Company**

be permitted to string the following described wires across the tracks of said railroad at the following described place:

City of Highland
Park, County of
Wayne

In private R.O.W. west of Woodward Avenue and
South of Sears Street, with:
4 - #2 T.B.W.P. copper wires @ 4800 volts

as indicated on the attached plans, when, as and if approved.

At the point of crossing said wires shall be constructed in accordance with this Commission's rules and regulations.

Given under our hands and the Official Seal of this
Commission at the City of Lansing, State of Mich-
igan, this 26th day of April
A. D. 19 38.

MICHIGAN PUBLIC UTILITIES COMMISSION
By **SERVICE**

JOHN J. O'BARA

Chairman,

IVAN E. RULL

Commissioner,

FLORENCE M. KIELY

Commissioner,

DON MCINTYRE

Commissioner,

GILBERT T. SHILSON

Commissioner.

Countersigned

S. A. LUND

Secretary

RECORDED RIGHT OF WAY NO. 31332



2013

DETROIT TERMINAL R.R. U-8000
 PRIVATE PROPERTY WEST OF WOODWARD SOUTH OF SEARS AND S. HIGHLAND PARK
 WAYNE

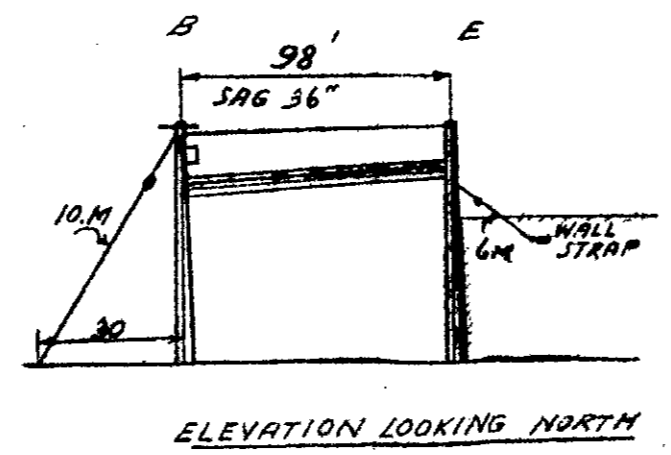
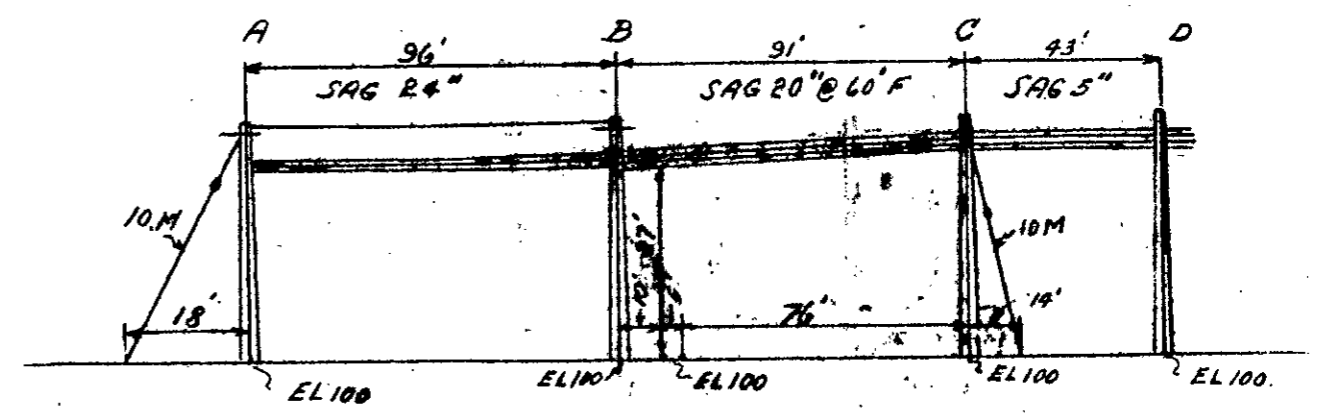
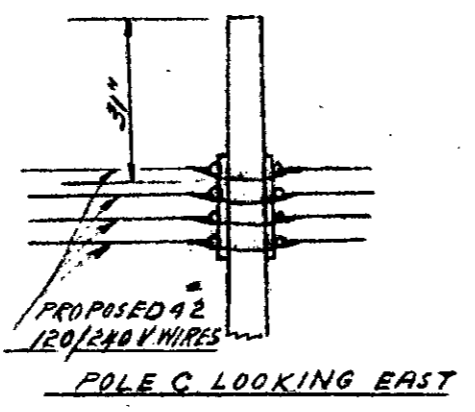
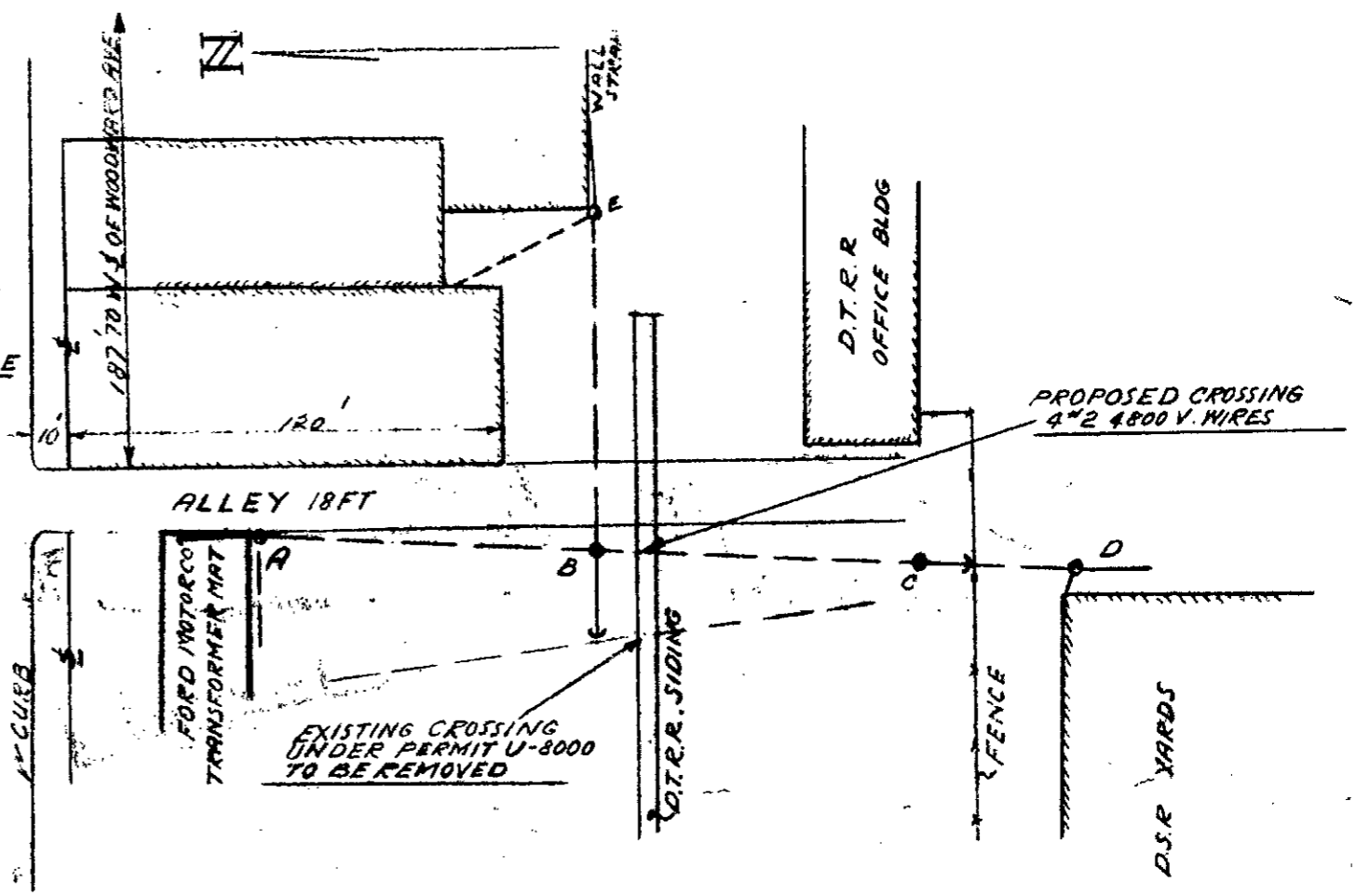
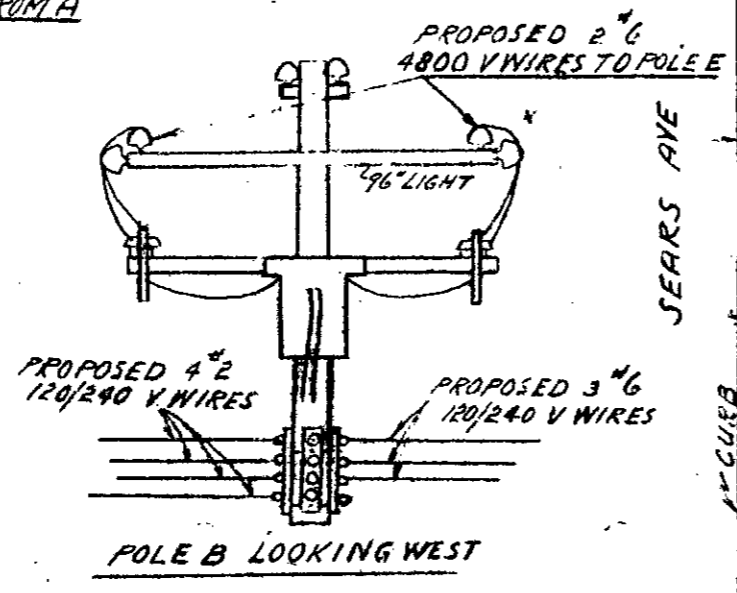
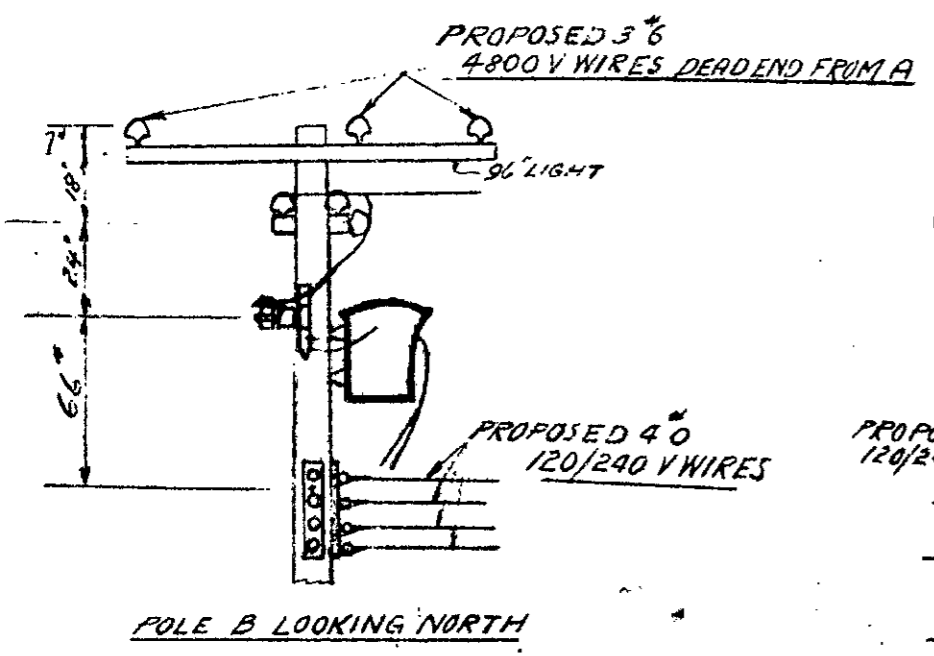

APPROVED
 FOR MICHIGAN PUBLIC SERVICE COMMISSION
 Ray K. [Signature]
 CHIEF ENGINEER
 ED2-8-908 DATE APR 26 1939
 FILE

CONDUCTORS			POLES				
NUMBER	SIZE	KIND	VOLTAGE	LOCATION	LENGTH	CLASS	TYPE
4	#2	TBWP	120/240	B-C-E	45'	2	W CEDAR
			4800	A-D	45'	4	"

NOTES

Materials shall be as noted in The Detroit Edison Company's Standard Specifications for Overhead railroad crossing issued December 22, 1935.
 The actual field dimensions may vary somewhat from those shown but the requirements of Order 1679 will be complied with.

MINIMUM CLEARANCES

Nearest pole to rail	7' sliding	12' Main Line
Wires over tracks	0 - 500 volts - 27"	500 - 7500 " - 32"
		-24000 " - 30"
Wires over P.R. Signal	0 - 500 volts - 2"	500 - 7500 " - 4"
		-24000 " - 0"

Drawn by C.C. Engineering Division 4-19-39
 Estimator WALSH C.E. Dept. DETROIT

DETROIT TERMINAL RAILROAD COMPANY

14517 WOODWARD AVENUE
DETROIT, MICH.

May 16th 1939
File 12-N-272

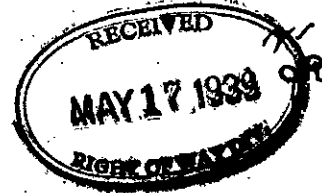

Michigan Public Utilities Commission,
Lansing, Michigan.

Gentlemen:

Detroit Terminal Railroad Company hereby waives hearing before the Michigan Public Utilities Commission in the matter of an application by the Detroit Edison Co. for authority to replace the existing crossing over this company's tracks in private property West of Woodward Avenue and South of Sears Avenue, City of Highland Park, Wayne County, Michigan, with four #2, 4800 volt wires, all according to Detroit Edison Plan No. RK-2018.

Very truly yours,

Chief Engineer.

cc: Mr. T. L. Hinks,
Right-of-Way Agent.

Handwritten notes:
12-2018
8-10-38
8-8-38

Vertical stamp:
RECEIVED
MAY 17 1939
RIGHT OF WAY DEPT

Detroit Edison Co



STATE OF MICHIGAN
Office of the Michigan Public ~~Utilities~~ Commission,
Service

Service

I, S. A. LUND, Secretary of the Michigan Public ~~Utilities~~ Commission

4783

Do Hereby Certify, That I have compared the annexed copy of Permit No. ED2-8-908

with the original

recorded in File No. ED2-8-908

and that it is a true and correct transcript therefrom, and of the whole of such original.

In Testimony Whereof, I have hereunto set my hand and affixed

the seal of the Commission, at Lansing, this 26th
day of April in the year of our Lord
one thousand nine hundred thirty-nine.

Secretary Michigan Public ~~Utilities~~ Commission
Service

4783

RECORDED RIGHT OF WAY NO. 21332

Submit One (1) Copy fo. each Span to
Real Estate and Rights of Way Dept.

THE DETROIT EDISON COMPANY

RAILROAD CROSSING REMOVAL

RX 2018

Span B-C

M.P.S.C. Permit and Date ED2-8-908

Railroad: Detroit Terminal R.R.

Location: IN PPTY W. of Woodward South of Sears, City of Highland Park, County
of Wayne.

Reason: Wires and Poles Removed

System Engineering Dept.

Date 2/13/78

By F. M. Hoffman *FMA*

RECORDED RIGHT OF WAY NO. 31332

**Detroit
Edison**

2000 Second Avenue
Detroit, Michigan 48226
(313) 237-8000

February 16, 1978

Mr. Ron Abee
Chief Engineer
Detroit Terminal Railroad
17541 Mound Road
Detroit, MI 48212

Dear Mr. Abee:

RE: Detroit Terminal Railroad File 12-M-272
Dated 05/16/39
Detroit Edison RX-2018

As of this date, the wires and poles are removed from
Span B-C.

The location is in private property west of Woodward,
South of Sears, City of Highland Park, County of Wayne.

Please acknowledge this letter by your signature below,
and return one copy to me for my files.

Very truly yours,

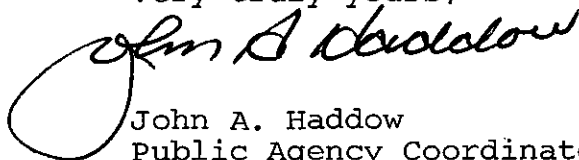

John A. Haddow
Public Agency Coordinator
Real Estate & Rights of Way

JAH/dm

ACKNOWLEDGED:

DETROIT TERMINAL RAILROAD

Ron Abee 2/24/78

RECORDED RIGHT OF WAY NO. 3/332

Detroit Edison

To: Records Center

March 1, 1978

From: Doreen McLain
Real Estate and Rights of Way Department

Subject: Distribution R/W crossing the Detroit Terminal R.R.,
City of Highland Park, Section 5, of Ten Thousand
Acre Tract, Greenfield Twp., Wayne County, RX-2018

The attached papers are for records center storage. Information about the completed transaction is shown in the following summary.

R.R. 1	R.R. INVOICE NO. M.P.S.C. NO. OR R.E. & R/W NO. 3 4	Update Type 10	D.E.C.O. RECORDS CENTER FILE NO. 11 15	R.X. NO. OR MAP NO. 16 20	Facility 21	Agreement Date 22 27
05	EP28708	1		02018	1	042639

Payment Frequency 28	Rental 29 33	OH-UG Code 34	Division 35	County 36	City or Township 38 44	Section 45
X	00000	1	2	13	HIGHLAN	05

Location									
47	IMPD WOLFWOODWARD SOF SEARS ST								86

Update Type Codes
 1 = New Agreement
 2 = Revised Agreement
 3 = Terminated Agreement

The Accounts Payable Department is requested to start or change the rental payment effective

Approved: *John A. Haselton*

- cc: Accounts Payable
 Service Planning
 System Engineering
 Transmission & Distribution

RECORDED RIGHT OF WAY NO. 31332