

To: Records Center

March 1, 1978

From: Doreen McLain
Real Estate and Rights of Way Department

Subject: Distribution R/W crossing the Detroit Terminal R.R.,
IN THE ROAD, City of Highland Park, Section 5
NW 1/4, Greenfield Twp., Wayne County, RX-201A

The attached papers are for records center storage. Information about the completed transaction is shown in the following summary.

R.R. 1	R.R. INVOICE NO. M.P.S.C. NO. OR R.E. & RW NO. 9	Update Type 10	D.E.C.O. RECORDS CENTER FILE NO. 15	R.X. NO. OR MAP NO. 20	Facility 21	Agreement Date 27
05	645-3246 E281250	1		0201A	1	022841

Payment Frequency 28	Rental 33	OH-UG Code 34	Division 35	County 36	City or Township 38	Section 45
X	00000	1	2	13	HIGHLAN	05

Location									
47	INTHIRDANE N OF DETROIT STRRYARDS								80

Update Type Codes
 1 = New Agreement
 2 = Revised Agreement
 3 = Terminated Agreement

The Accounts Payable Department is requested to start or change the rental payment effective

Approved: *John A. Dardora*

- cc: Accounts Payable
 Service Planning
 System Engineering
 Transmission & Distribution

RECORDED RIGHT OF WAY NO. 31331

**Detroit
Edison**

2000 Second Avenue
Detroit, Michigan 48226
(313) 237-8000

February 16, 1978

Mr. Ron Abee
Chief Engineer
Detroit Terminal Railroad
17541 Mound Road
Detroit, MI 48212

Dear Mr. Abee:

RE: Wire Crossing Permit ED2-8-1250
Dated February 28, 1941
Detroit Edison RX-201A

As of this date, the poles and wires are removed from
Span B-D.

The location is in Third Avenue, just North of Detroit
Street Railroad Yards, City of Highland Park, Wayne
County.

Please acknowledge this letter by your signature below,
and return one copy to me for my files.

Very truly yours,

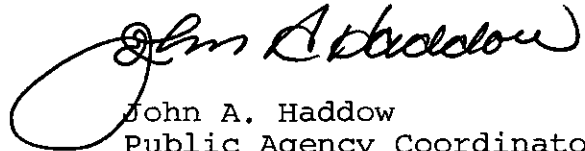

John A. Haddow
Public Agency Coordinator
Real Estate & Rights of Way

JAH/dm

Acknowledged:

THE DETROIT TERMINAL RAILROAD

Ron Abee 2/24/78

RECORDED RIGHT OF WAY NO. 31331

Submit One (1) Copy for each Span to
Real Estate and Rights of Way Dept.

THE DETROIT EDISON COMPANY

RAILROAD CROSSING REMOVAL

RX 201A

Span B-D

M.P.S.C. Permit and Date ED2-8-1250 2-28-41

Railroad: Detroit Terminal R.R.

Location: In Third Ave. just N. of Detroit Street R.R. Yards, City of
Highland Park, County of Wayne.

Reason: Poles and wires removed.

System Engineering Dept.

Date 2/13/78

By F. M. Hoffman/am *FMH*

RECORDED RIGHT OF WAY NO. 3/331

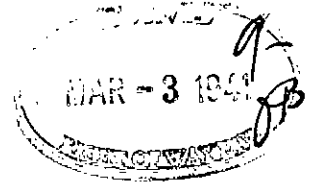

STATE OF MICHIGAN

Office of the Michigan Public Service Commission, } ss.

I, S. A. LUND, Secretary of the Michigan Public Service Commission

Do Hereby Certify, That I have compared the annexed copy of ED2-8-1250

5-107

with the original

recorded in ED2-8-1250

and that it is a true and correct transcript therefrom, and of the whole of such original.

In Testimony Whereof, I have hereunto set my hand and affixed

the seal of the Commission, at Lansing, this twenty eighth day of February in the year of our Lord one thousand nine hundred forty one.



[Handwritten signature of S. A. Lund]

Secretary, Michigan Public Service Commission

5-107
RECORDED RIGHT OF WAY NO. 3/33

PROPOSED LINE CROSSING OVER THE DETROIT STREET R.R. EXIS. PERMIT NUMBER U-5046
 IN THIRD AVE JUST NORTH OF DETROIT STREET R.R. YARDS CITY OF HIGHLAND PARK
 SECTION 5 NW 14 TOWNSHIP GREENFIELD T. R. COUNTY WAYNE

NOTES

MATERIALS SHALL BE AS NOTED IN THE DETROIT EDISON COMPANY'S STANDARD SPECIFICATIONS FOR OVERHEAD LINE CONSTRUCTION AT RAILROAD CROSSINGS DATED MARCH 23, 1939.

ACTUAL FIELD DIMENSIONS MAY VARY SOMEWHAT FROM THOSE SHOWN BUT THE REQUIREMENTS OF ORDER NO. 1679 WILL BE COMPLIED WITH.

MINIMUM CLEARANCES

NEAREST POLE TO RAIL	SIDING	7 FT.
	MAIN LINE	12 FT.
WIRES OVER TRACKS	0 - 500 VOLTS	27 FT.
	500 - 7500 VOLTS	28 FT.
	24000 VOLTS	30 FT.
WIRES OVER R. R. SIGNAL	0 - 500 VOLTS	2 FT.
	500 - 7500 VOLTS	4 FT.
	24000 VOLTS	6 FT.

CONDUCTORS				POLES			
NUMBER	SIZE	KIND	VOLTAGE	LOCATION	LENGTH	CLASS	TYPE
3	#2	WPK	4800	A-C	40'	3	W.CEDAR
				B	40'	1	" "
				D	40'	2	" "

DRAWN BY J. WHITE ENGINEERING DIVISION DATE 2-19-41
 ESTIMATOR G. WALSH OVERHEAD LINES DEPT. DETROIT

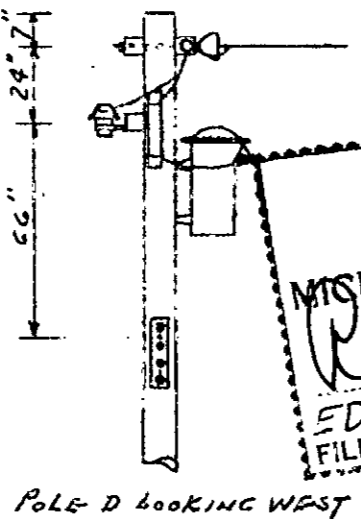
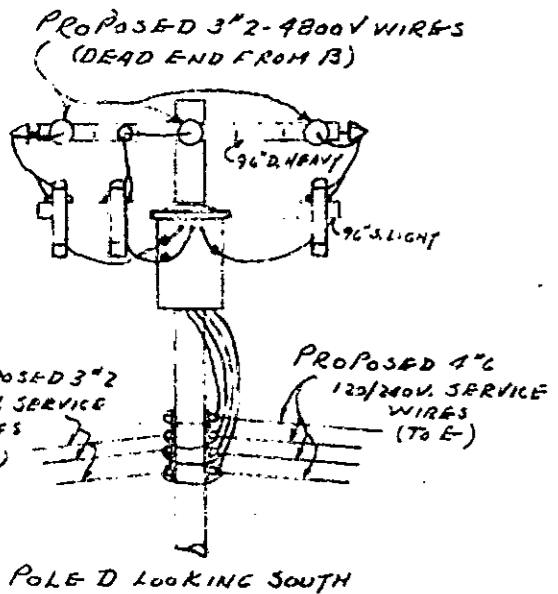
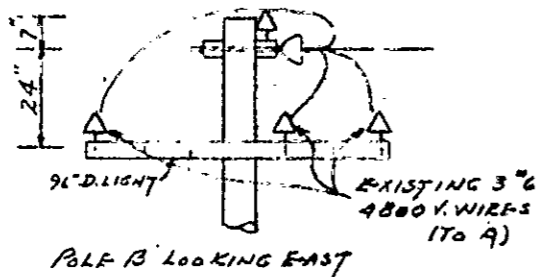
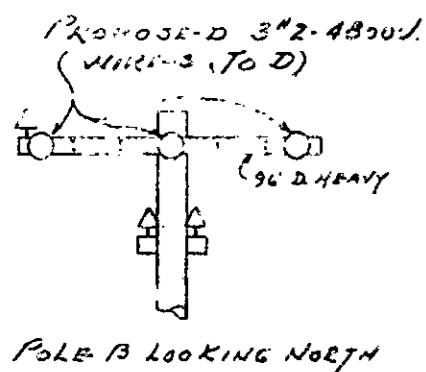

APPROVED
 FOR
 MICHIGAN PUBLIC SERVICE
 COMMISSION
Ray K. Kelland
 CHIEF ENGINEER
 FILE ED2-8-1250 DATE FEB 27 1941

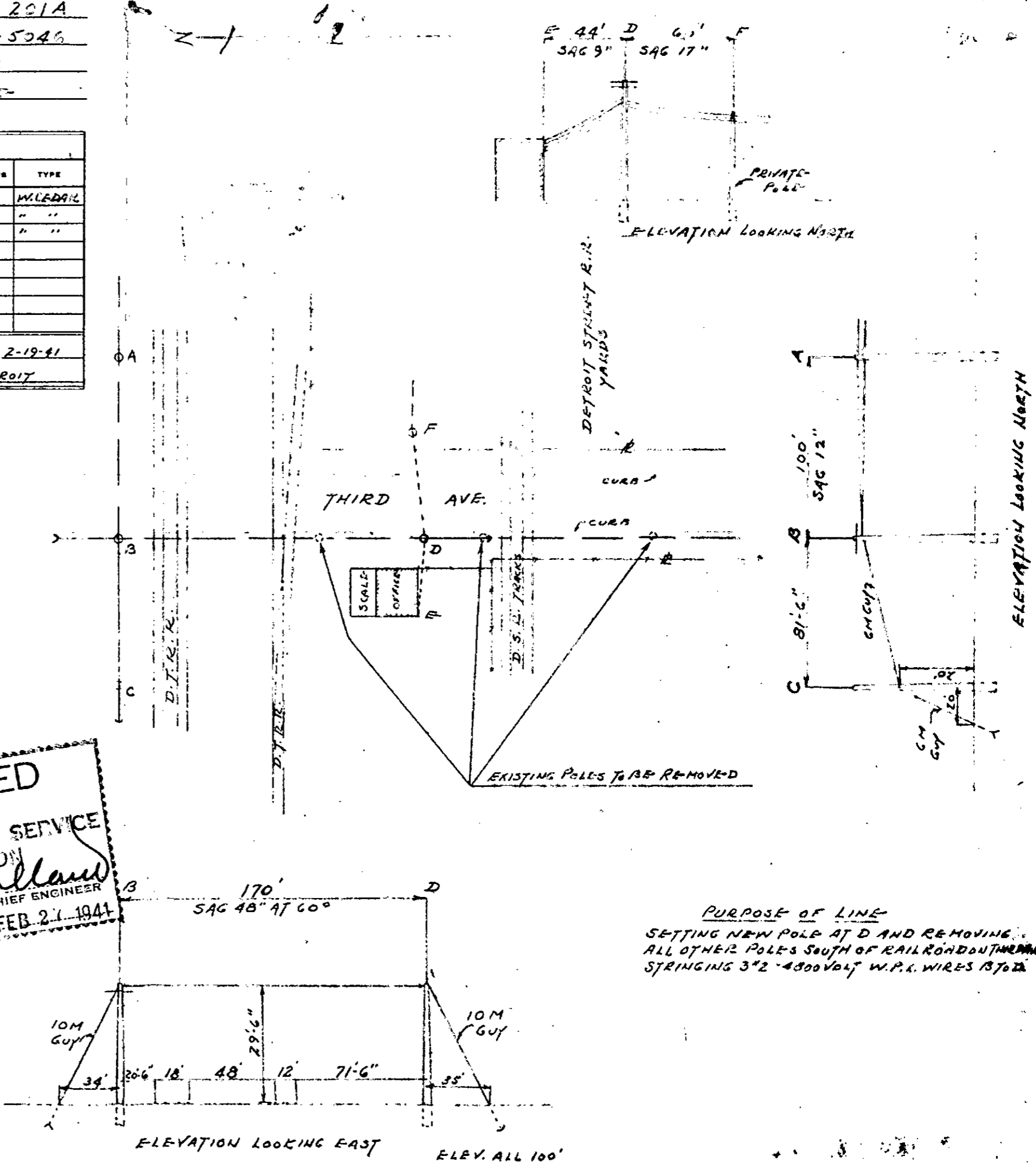

PURPOSE OF LINE
 SETTING NEW POLE AT D AND REMOVING ALL OTHER POLES SOUTH OF RAILROAD ON THE MAIN LINE. STRINGING 3#2 4800VOLT W.P.K. WIRES B TO D.

STATE OF MICHIGAN
BEFORE MICHIGAN PUBLIC UTILITIES SERVICE COMMISSION

Standard Railroad Wire-Crossing Permit No. ED2-8-1250
Cancels U-5046

In Re Application of Detroit Edison Company, Detroit, Michigan.

Pursuant to Act No. 171 of the Session Laws of 1893, as amended, application having been made to Michigan Public Utilities Commission by said Detroit Edison Company Service

for permission to string wires across the tracks of the Detroit Terminal Railroad Company

and said Detroit Edison Company

having conformed to the Commission's rules governing the filing of notices and issuing of permits for the construction of electrical lines and said rail road company having waived the right of notice and hearing provided for in said act

THEREFORE, It is ordered that said Detroit Edison Company

be permitted to string the following described wires across the tracks of said railroad at the following described place:

City of Highland Park,
County of Wayne,
Michigan:-

In Third Avenue, North of Detroit Street
Railway yards, with:-

3-#2 Copper Wires to carry 4800 volts.

as indicated on the attached plans, when, as and if approved.

At the point of crossing said wires shall be constructed in accordance with this Commission's rules and regulations.

Given under our hands and the Official Seal of this
Commission at the City of Lansing, State of Mich-
igan, this 28th day of February
A. D. 19 41

MICHIGAN PUBLIC UTILITIES SERVICE COMMISSION
By

JOHN J. O'HARA

Chairman,

IVAN E. HULL

Commissioner,

FLORENCE M. KIELY

Commissioner,

GILBERT T. SHILSON

Commissioner,

Countersigned

S. A. LUND

Secretary



Commissioner.

RECORDED RIGHT OF WAY NO. 3/33/