

DE ORIG.



6737 Southpoint Drive, South
Suite 100
Jacksonville, Florida 32216
(904) 279-4515
FAX (904) 279-4586
or (904) 279-4581

T. R. Jackson
Assistant Vice President

DUPLICATE ORIGINAL

March 19, 1992

Mr. Thomas Wilson
Detroit Edison Company
2000 Second Avenue
Detroit, MI 48226

Dear Mr. Wilson:

This letter will confirm our understanding and agreement that for One Dollar and Other Valuable Consideration paid by the Detroit Edison Company (DE) effective as of April 1, 1992, CSX Transportation, Inc., hereby waives future rental requirements (provided there shall be no refunds of any prepaid rentals) and termination rights for the now existing aerial and underground wireline and pipeline crossing agreements identified on the attached Exhibit A. Except as described in the preceding sentence, the terms of all such agreements remain unaltered and in full force and effect.

Please indicate your understanding and acceptance of the foregoing by having the duplicate original of this letter executed on your behalf and return to the undersigned. No further revision of the individual license agreements will be necessary to effect the changes set forth in the first sentence of the first paragraph other than this letter exchange, which will constitute a supplement to each agreement.

By: CSX TRANSPORTATION, INC.
CSX Real Property, Inc.
Its Attorney-in-Fact

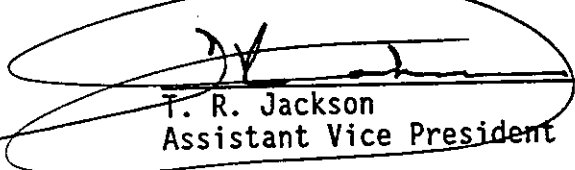
T. R. Jackson
Assistant Vice President

TRJ:hkm

THE FOREGOING IS UNDERSTOOD AND AGREED THIS 19th DAY OF MARCH, 1992.

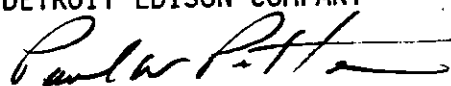
DETROIT EDISON COMPANY

BY: _____
Title: Paul W. Potter, Director -
Corporate Real Estate

RECORDED RIGHT OF WAY NO. 27028

SEE:
RECORDED RIGHT OF WAY NO. 42790

INTERDEPARTMENT CORRESPONDENCE

Real Estate and Rights of Way Department

TO RECORDS CENTER:

Attached is fully executed copy of agreement/~~permit~~ from:

The Chesapeake and Ohio Railway Company

R.R. File No. 131-4-11754

Facilities Covered:

Three No. 000 ACSR 13,200-volt wires and One No. 0 ACSR neutral wire.
(Span B-C)

Specific Location:

In private property at a point 540 feet East of the center line of Childs Road extended and 250 feet North of the center line of Buno Road, one mile Southeast of the Village of Milford.

R. R. Valuation Station 10854 + 90 Mile Post 68-396

City/Village _____ Township Milford, SW 1/4 of Sec. 24

County Oakland Detroit Edison Plan No. RX-3407A

Agreement/~~Permit~~ Date June 28, 1971 R. R. Plan No. Used DECo. Plan

Preparation Fee \$100.00 Annual Rental \$50.00

Supersedes and Cancels Agreement dated Jan. 26, 1959 R/W No. 20134

This is a Supplemental Agreement and is to be made a part of R/W _____

Attached Grand Trunk Western Railroad Permit No. _____ to be made a part of R/W No. 9064.

REFERRED TO
9-2-71 BK
MIL 20

RECORDS CENTER
RECEIVED AUG 31 71
TICKLER MADE
CLASSIFIED
HB:dmk

GEN'L. ACCTG. DEPT.
ENTERED - ~~CANCELLED~~
CONTRACT BOOK NO. _____
DATE 10/27/71
BY _____
CHECKED BY [Signature]

[Signature]
I. W. Gamble, Supervisor of Rights of Way
Real Estate and Rights of Way Department
[Signature]
Sec 24
SW1/4, S1/2

RECORDED RIGHT OF WAY NO. 21238

The Chesapeake and Ohio Railway Company

WIRE AND/OR CABLE LINE CROSSINGS

THIS AGREEMENT, made as of this 28th day of June, 1971, between
THE CHESAPEAKE AND OHIO RAILWAY COMPANY, a Virginia Corporation, hereinafter called
"Railway", and THE DETROIT EDISON COMPANY, a New York Corporation

hereinafter called "Licensee" (all words herein referring to Licensee to be taken of such number and gender as the context may require):

WITNESSETH THAT:

WHEREAS, Licensee desires to construct, operate and maintain a wire and/or cable line over
and across the right of way, tracks and wires of Railway, consisting of three (3) No. 000 ACSR
13,200 volt wires and one (1) No. 0 neutral wire (Span B-C)
at a point located at Station 10854 plus 90
Mile Post --- Feet, Toledo
Subdivision, Detroit Terminal Division, at or near Milford
---, County of Oakland, State of Michigan;
said crossing, together with the necessary poles, towers, conduits, fixtures, and appurtenances thereto, being in
accordance with attached Licensee's Plan RX3407A, dated 6-2-71
marked for identification "Exhibit A" ---

--- which are made a part of this agreement and

--- which are incorporated herein and made a part hereof by reference; said crossing and the aforesaid facilities and appurtenances thereto being hereinafter referred to collectively as "Crossing"; and

WHEREAS, Railway is willing for said Crossing so to be constructed, operated and maintained, upon the following terms, covenants, conditions and limitations;

NOW, THEREFORE, in consideration of the premises and the observance by Licensee of the terms, covenants, conditions and limitations hereinafter set forth, it is agreed by and between the parties hereto as follows:

1. Railway hereby licenses and permits Licensee, at its sole risk, cost and expense, to construct, operate, maintain and renew said Crossing across the right of way, tracks, wires and any other facilities of Railway

--- and of any other person, firm, corporation or association which now or may hereafter have any such facilities on Railway's right of way at or in the vicinity

RECORDED RIGHT OF WAY NO. 27082

MILFORD TWP

and the sum of ~~xxxxxx~~ Dollars (\$~~xxxxxx~~) such that the sum of the amount paid by Licensee upon by the parties ~~xxxxxx~~ and ~~xxxxxx~~ the event of termination of the agreement ~~xxxxxx~~ Railway shall refund to Licensee the amount ~~xxxxxx~~ Licensee to Railway ~~xxxxxx~~

11. Licensee shall pay to Railway upon the execution of this agreement a license fee of ONE HUNDRED DOLLARS (\$100.00) toward the cost of preparation of this agreement and supervision expense. Licensee shall also pay to Railway as a rental charge for the use of its premises the sum of FIFTY DOLLARS (\$50.00) per annum in advance for each and every year or fraction thereof during which this agreement shall remain in force and effect.

12. This agreement shall continue in force and effect until terminated by ninety (90) days' notice in writing from either party to the other of its intention to terminate the same, except that termination of this agreement shall not relieve or release Licensee from any liability or obligation which may have been incurred or assumed by Licensee hereunder prior to the termination hereof.

13. In the event this agreement shall be at any time terminated as herein provided, or Licensee, in the judgment of Railway, shall have abandoned said Crossing, said Licensee shall, at its sole risk, cost and expense, forthwith upon request of Railway so to do, remove said Crossing from and across the right of way and premises aforesaid, and in the event of the failure or refusal of Licensee, within thirty (30) days after receipt of such request, to remove said Crossing and restore and leave said right of way and premises in as good condition as before the installation of said Crossing, then and in that event Railway, without incurring any liability to Licensee, may, at its option, remove said Crossing. Licensee shall reimburse Railway for the entire cost and expense of such removal and restoration upon receipt of Railway's bill therefor.

14. The terms and provisions of this agreement shall inure to the benefit of and be binding upon the successors and assigns of Railway, ~~---~~ and any other person, firm, corporation or association now or hereafter having facilities on Railway's right of way at or in the vicinity of the Crossing, and the successors, heirs, personal representatives and assigns of Licensee. No assignment by Licensee of this agreement or of any rights hereunder shall be made without the prior written consent of Railway.

15. Agreement dated January 26, 1959, between the above parties covering a crossing at the above location is hereby terminated.

IN TESTIMONY WHEREOF, the parties hereto have caused these presents to be duly executed.

Approved as to form:

THE CHESAPEAKE AND OHIO RAILWAY COMPANY

By *[Signature]*
General Manager

ASSISTANT GENERAL ATTORNEY

THE DETROIT EDISON COMPANY
Licensee

By *[Signature]*
Director

Real Estate and Rights of Way Department
(title)

[Signature]

Approved
[Signature]

RECORDED RIGHT OF WAY NO. 27028

APPROVED AS TO FORM

THE DETROIT EDISON COMPANY

2000 SECOND AVENUE
DETROIT, MICHIGAN 48226

July 14, 1971

Railroad File No. 131-4-11754

Mr. R. C. Tench, Chief Engineer
The Chesapeake and Ohio Railway Co.
C & O Building, 405 Eleventh Avenue
P. O. Box 1800
Huntington, West Virginia 25718

Dear Mr. Tench:

We are returning agreement/~~permits~~ in duplicate, covering our facilities over your tracks and ~~for~~ right of way as shown on our Plan RX-3407A (Span B-C) and located as follows:

In private property 540 feet East of the center line of Childs Road extended and 250 feet North of the center line of Buno Road. One mile Southeast of the Village of Milford.
Val. Sta. 10854 + 90 M.P. 68-396

City/Village _____ Township, Milford, SW 1/4 of Sec. 24
County Oakland. The agreement/~~permits~~ has been signed for our Company.

Will you please return one fully executed copy of this agreement/~~permits~~ to us for our records.

Yours very truly,

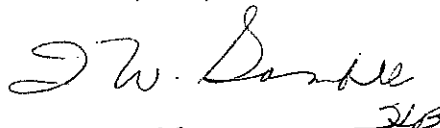

I. W. Gamble
Supervisor of Rights of Way
Real Estate and Rights of Way Dept.

HB:dmk

RECORDED RIGHT OF WAY NO. 27028



THE CHESAPEAKE AND OHIO RAILWAY COMPANY
THE BALTIMORE AND OHIO RAILROAD COMPANY

ENGINEERING DEPARTMENT
CHESAPEAKE AND OHIO BUILDING
HUNTINGTON, W. VA.

R C TENCH
CHIEF ENGINEER-SYSTEM

I. W. GAMBLE
ls
JUL 6 1971
JUB
R/E & R/W DEPT:

July 1, 1971

File: 131-4-11754 IF/40

Mr. I. W. Gamble
Supervisor of Rights of Way
Real Estate and Rights of Way Department
The Detroit Edison Company
2000 Second Avenue
Detroit, Michigan

Dear Mr. Gamble:

This refers to your letter June 8, 1971, Plan RX-3407A, covering a proposed power line crossing our tracks and Right of way at Station 10854 plus 90, on our Toledo Subdivision, Detroit Terminal Division.

With the understanding that the enclosed proposed agreement has been properly executed, and returned to the undersigned, this is your authority to proceed with the construction. Three days' advance notice, in writing, of the start of construction shall be submitted to Superintendent M. W. Karsten, Detroit, Michigan.

Very truly yours,

THE CHESAPEAKE AND OHIO RAILWAY COMPANY

R. C. Tench
R. C. Tench
Chief Engineer - System

RECORDED RIGHT OF WAY NO. 27028

-D.O. A-54185
6-2-71

THE DETROIT EDISON COMPANY

2000 SECOND AVENUE
DETROIT, MICHIGAN 48226

July 8, 1971

Michigan Public Service Commission
Lansing 13, Michigan



Gentlemen:

The Detroit Edison Company, Detroit, Michigan, hereby makes application for authority to string the following wires over the tracks of the Chesapeake and Ohio Railway in the S.W. 1/4 of Section 24, Milford Township, T-2N, R7E, Oakland County.

Span B-C

Three #000 ACSR 13,200 volt wires and one #0 ACSR neutral wire over the tracks of the Chesapeake and Ohio Railway located in private property at a point 540' east of the centerline of Childs Road, extended and 250' north of the centerline of Buno Road one mile southeast of the village of Milford.

Railroad Valuation Station 10854 + 90
Mile Post 68-396

The proposed wire crossing will be constructed in accordance with specifications of the Michigan Public Service Commission and the construction standards of The Detroit Edison Company, approved by the Michigan Public Service Commission on July 19, 1939, File ED 2-9.01.

- Enclosed is a waiver of hearing granted by the Railroad Company. Dated 6-28-71
- Waiver of hearing by the Railroad Company is covered by blanket waiver. **R.R. File No. 131-4-11754**
- This application covers reconstruction of existing crossing and will cancel and supersede wire crossing permit No. **ED2-8-4540** dated 12-26-58
- This is a new crossing.

CN:dmk Reference number of construction drawing is RX- 3407A

Yours very truly,

Permit No. ED2-8-6836

Date 7-15-71

By J. M. Hoppe

I. W. Gamble
Supervisor of Rights of Way
Real Estate and Rights of Way Dept.

Check in circle indicates statement applicable.

RECORDED RIGHT OF WAY NO. 27028

THE DETROIT EDISON COMPANY

2000 SECOND AVENUE Station: 10854 plus 90

DETROIT, MICHIGAN 48226 Location: _____

TO:

June 8, 1971

Sub-Division: Toledo

Division: Detroit Terminal

M.P.S.C. Hearing Waived 6-28-71

The Chesapeake and Ohio Railway Company

Mr. R. C. Tench, Chief Engineer
The Chesapeake and Ohio Railway Company
C & O Building, 405 Eleventh Avenue
P. O. Box 1800
Huntington, West Virginia 25718

R. C. Tench
Chief Engineer-System

Your File RX-3407-A

C. & O. File 131-4-11754

Proposed Overhead Wire Crossing:

Three No. 000 ACSR 13,200-volt wires and One No. 0 ACSR neutral wire. (Span B-C)

Specific Location

In private property at a point 540 feet East of the center line of Childs Road, extended and 250 feet North of the center line of Buno Road, one mile Southeast of the Village of Milford.

R. R. Valuation Station 10854 + 90 R. R. Mile Post 68 - 396

City/Village _____ Township Milford, SW 1/4 of Sec. 24

County Oakland Detroit Edison Plan Attached RX-3407A

This is a New Crossing _____ This is a Reconstruction of Existing Crossing X

Previous Agreement Information (if any) Date January 26, 1959 (R. R. Plan) A-581128 (11-28-58)

Blanket Waiver of Hearing Covers _____ Waiver of Hearing Requested in duplicate
(Waiver of Hearing to be mailed to applicant listed below)

All construction will be done in accordance with the rules and regulations of the Michigan Public Service Commission.

I. W. Gamble
I. W. Gamble, Supervisor of Rights of Way
Real Estate and Rights of Way Department

CN:dmk

RECORDED RIGHT OF WAY NO. 27028

THE DETROIT EDISON COMPANY

2000 SECOND AVENUE

DETROIT, MICHIGAN 48226

TO:

June 8, 1971

Mr. R. C. Tench, Chief Engineer
The Chesapeake and Ohio Railway Company
C & O Building, 405 Eleventh Avenue
P. O. Box 1800
Huntington, West Virginia 25718

Proposed Overhead Wire Crossing:

Three No. 000 ACSR 13,200-volt wires and One No. 0 ACSR neutral wire. (Span B-C)

Specific Location

In private property at a point 540 feet East of the center line of Childs Road, extended and 250 feet North of the center line of Buno Road, one mile Southeast of the Village of Milford.

R. R. Valuation Station 10854 + 90 R. R. Mile Post 68-396

City/Village _____ Township Milford, SW 1/4 of Sec. 24

County Oakland Detroit Edison Plan Attached RX-3407A

This is a New Crossing _____ This is a Reconstruction of Existing Crossing X

Previous Agreement Information (if any) Date January 26, 1959 (R. R. Plan) A-581128 (11-28-58)

Blanket Waiver of Hearing Covers _____ Waiver of Hearing Requested in duplicate
(Waiver of Hearing to be mailed to applicant listed below)

All construction will be done in accordance with the rules and regulations of the Michigan Public Service Commission.

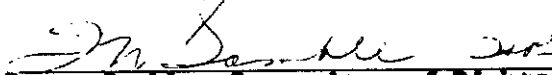
I. W. Gamble, Supervisor of Rights of Way
Real Estate and Rights of Way Department

RECORDED RIGHT OF WAY NO. 270289

RX 3407 A

D.O. A-54185

PROPOSED LINE CROSSING OVER CHESAPEAKE RAILROAD R.R. EXISTING PERMIT NUMBER ED2-B-4540
 IN PRIVATE PROPERTY APPROX. 540' EAST OF CHILDS LAKE APPROX. ONE MILE SOUTH
R.D. 4 EXTENDED + 250' NORTH OF BUNO RD. CITY OF THE VILLAGE OF MILFORD
 SECTION 24 S.E. 14 TOWNSHIP MILFORD T 2N R 7E COUNTY OAKLAND

NOTES	CONDUCTORS				POLES			
	NUMBER	SIZE	KIND	VOLTAGE	LOCATION	LENGTH	CLASS	TYPE
MATERIALS SHALL BE AS NOTED IN THE DETROIT EDISON COMPANY'S GENERAL SPECIFICATIONS FOR OVERHEAD LINE CONSTRUCTION AT RAILROAD CROSSINGS DATED MARCH 1955. ACTUAL FIELD DIMENSIONS MAY VARY SOMEWHAT FROM THOSE SHOWN BUT THE REQUIREMENTS OF ORDER NO. 1679 OF MICHIGAN PUBLIC SERVICE COMMISSION AS REVISED JAN. 1, 1944, WILL BE COMPLIED WITH.	SPAN B-C				A	40	5	W.D. 6.0
	3	000	ACSR	13,200	B	50	4	" 7.0
	1	0	ACSR	NEUTRAL	C	50	4	" 7.0
					D	40	5	" 6.0
					E	25	6	" 6.0
MINIMUM CLEARANCES								
NEAREST POLE TO RAIL	SIDING	7 FT						
	MAIN LINE	12 FT						
WIRES OVER TRACKS	0 - 750 VOLTS	27 FT						
	750 - 15,000 VOLTS	28 FT						
	15,000 - 50,000 VOLTS	30 FT						
WIRES OVER R R SIGNAL	0 - 750 VOLTS	2 FT						
	750 - 8,700 VOLTS	4 FT						
	8,700 - 50,000 VOLTS	6 FT						
DESIGNED BY <u>W.K. Shoemaker</u> PLANNING & PROJECT ENGINEERING DEPT. DATE <u>6-2-71</u> ESTIMATOR <u>O. JOHNSON</u> OVERHEAD LINES DEPT. <u>Pent Ser. CTR.</u>								

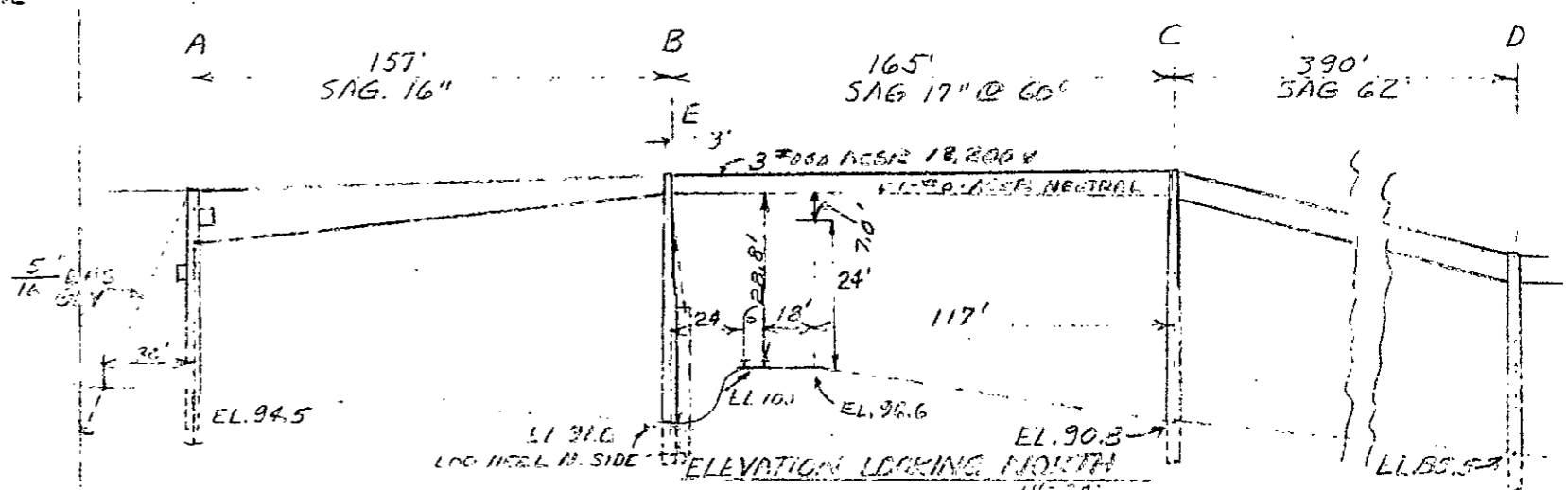
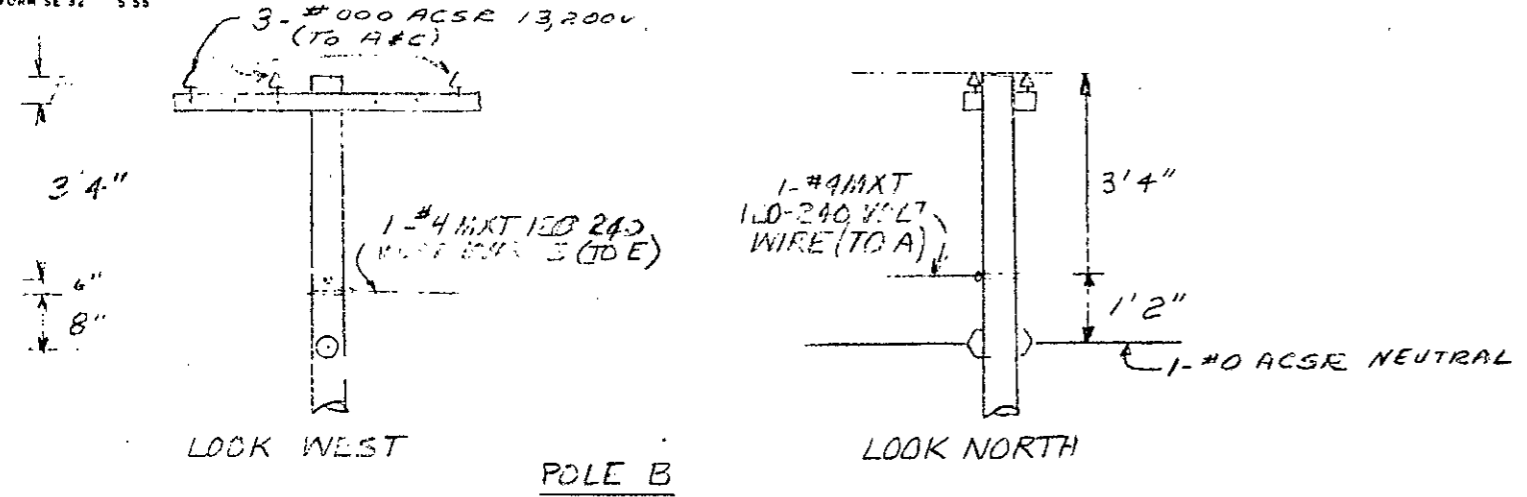
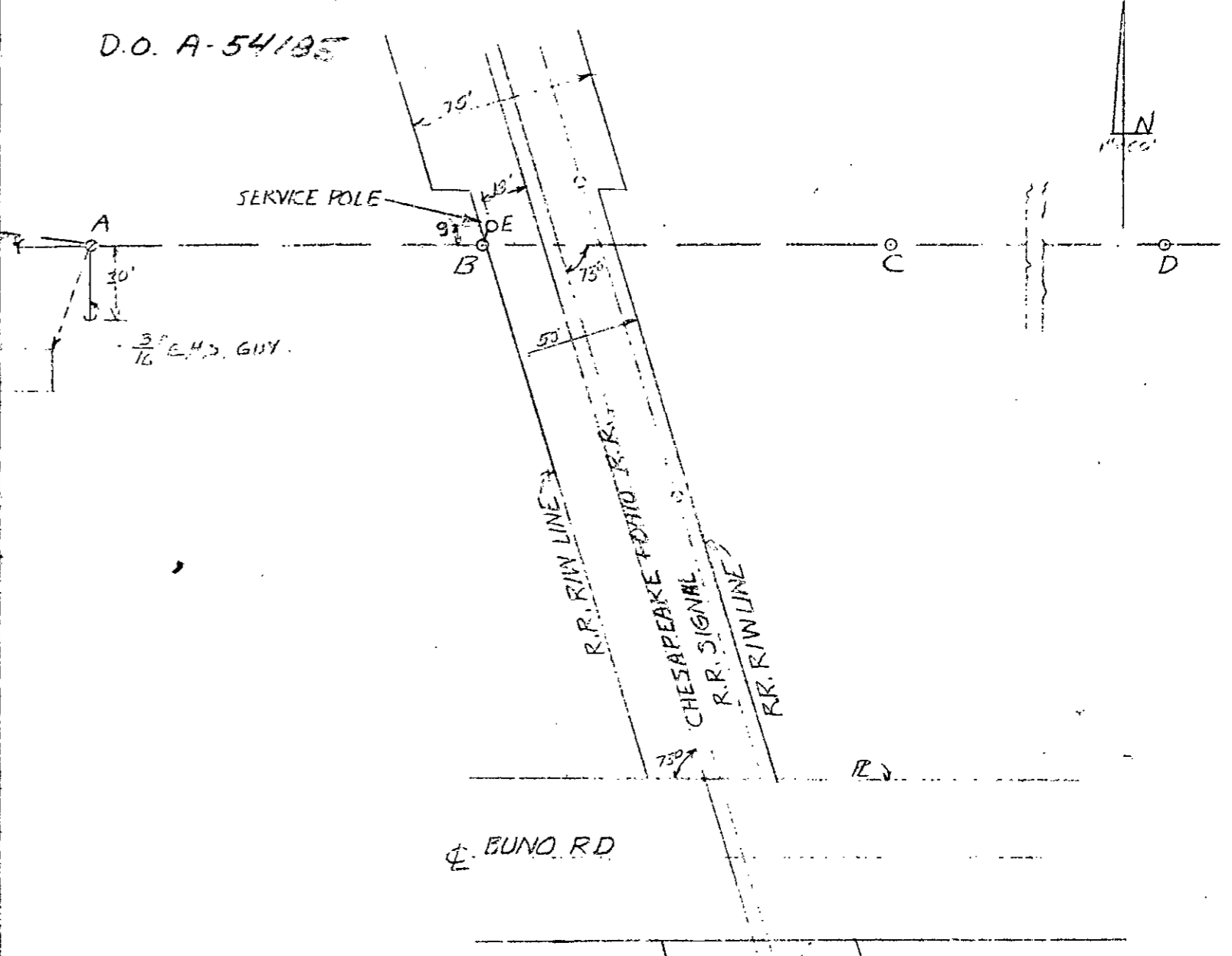

PROPOSED LINE CROSSING OVER CHESAPEAKE AND OHIO R.R. EXISTING PERMIT NUMBER ED2-B-4540
 IN PRIVATE PROPERTY APPROX. 540' EAST OF CHILDS LAKE APPROX. ONE MILE SOUTHEAST OF
RD. E EXTENDED + 250' NORTH OF BUNO RD. E CITY OF THE VILLAGE OF MILFORD,
 SECTION 24 S.E. 1/4 TOWNSHIP MILFORD T 2N R 7E COUNTY OAKLAND

NOTES
 MATERIALS SHALL BE AS NOTED IN THE DETROIT EDISON COMPANY'S GENERAL SPECIFICATIONS FOR OVERHEAD LINE CONSTRUCTION AT RAILROAD CROSSINGS DATED MARCH 1955.
 ACTUAL FIELD DIMENSIONS MAY VARY SOMEWHAT FROM THOSE SHOWN BUT THE REQUIREMENTS OF ORDER NO. 1679 OF MICHIGAN PUBLIC SERVICE COMMISSION AS REVISED JAN. 1, 1944, WILL BE COMPLIED WITH.

MINIMUM CLEARANCES

NEAREST POLE TO RAIL	SIDING	7 FT
	MAIN LINE	12 FT
WIRES OVER TRACKS	0 - 750 VOLTS	27 FT
	750 - 15,000 VOLTS	28 FT
	15,000 - 50,000 VOLTS	30 FT
WIRES OVER R R SIGNAL	0 - 750 VOLTS	2 FT
	750 - 8,700 VOLTS	4 FT
	8,700 - 50,000 VOLTS	6 FT

DESIGNED BY W.K. Shoemaker PLANNING & PROJECT ENGINEERING DEPT. DATE 6-2-71
 ESTIMATOR A. Johnson OVERHEAD LINES DEPT. Plant Ser. CTR.

CONDUCTORS				POLES			
NUMBER	SIZE	KIND	VOLTAGE	LOCATION	LENGTH	CLASS	TYPE SET
SPAN B-C				A	40	5	WOOD 6.0
3	000	ACSR	13,200	B	50	4	" 7.0
1	0	ACSR	NEUTRAL	C	50	4	" 7.0
				D	40	5	" 6.0
				E	25	6	" 6.0

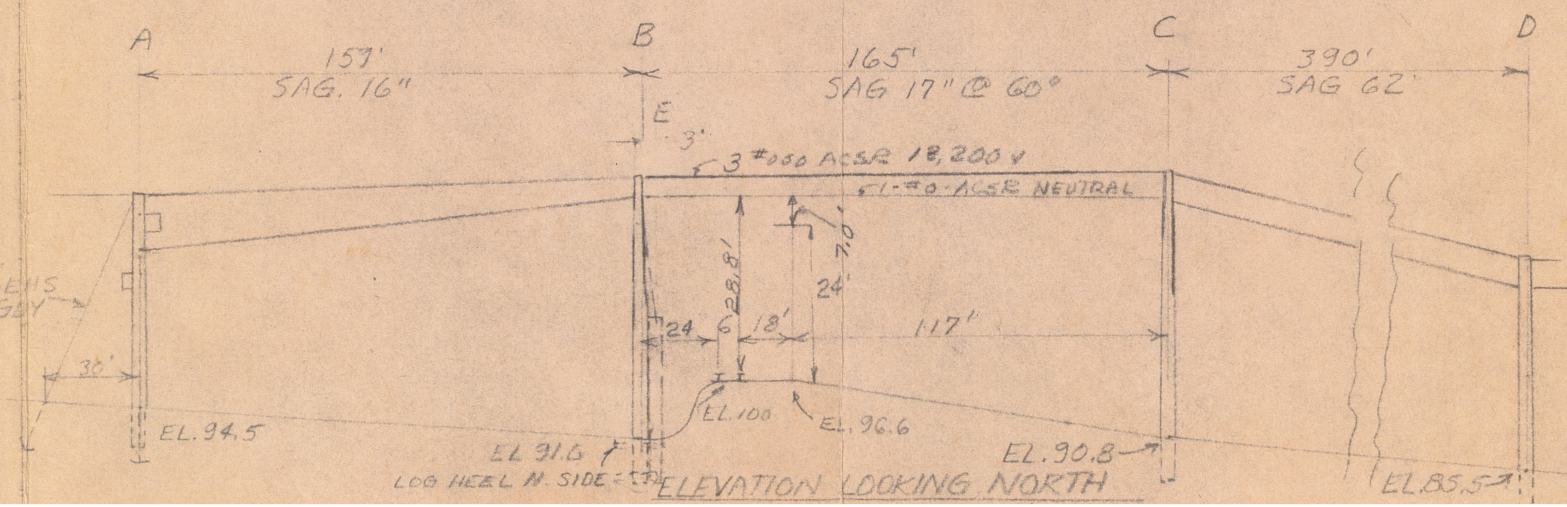
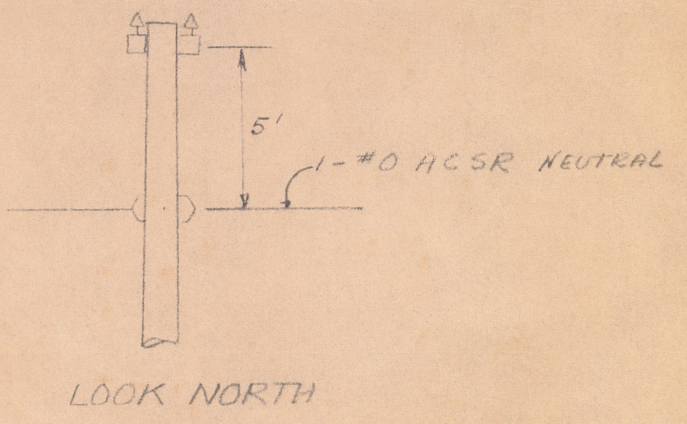
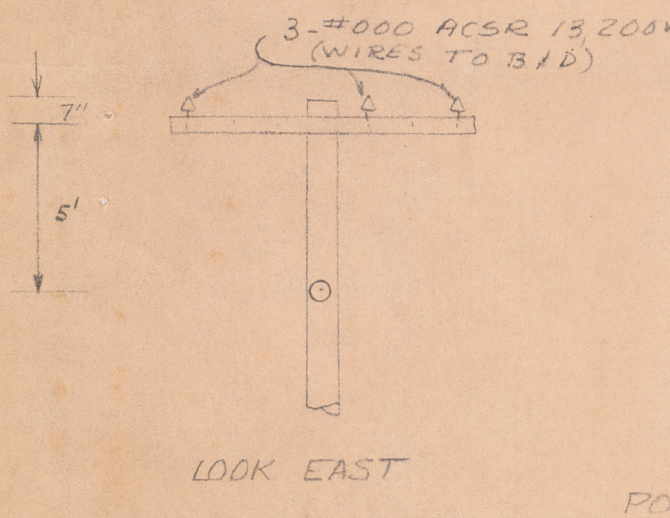
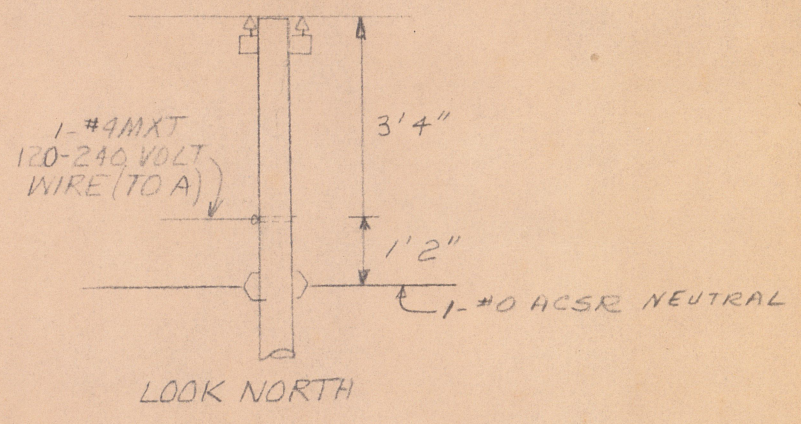
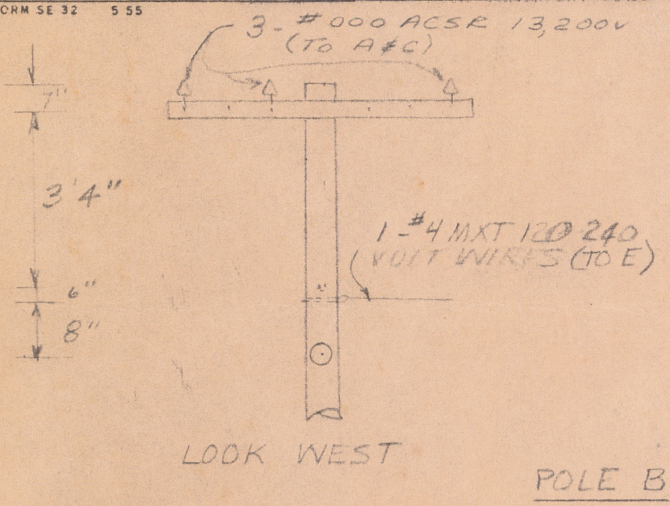
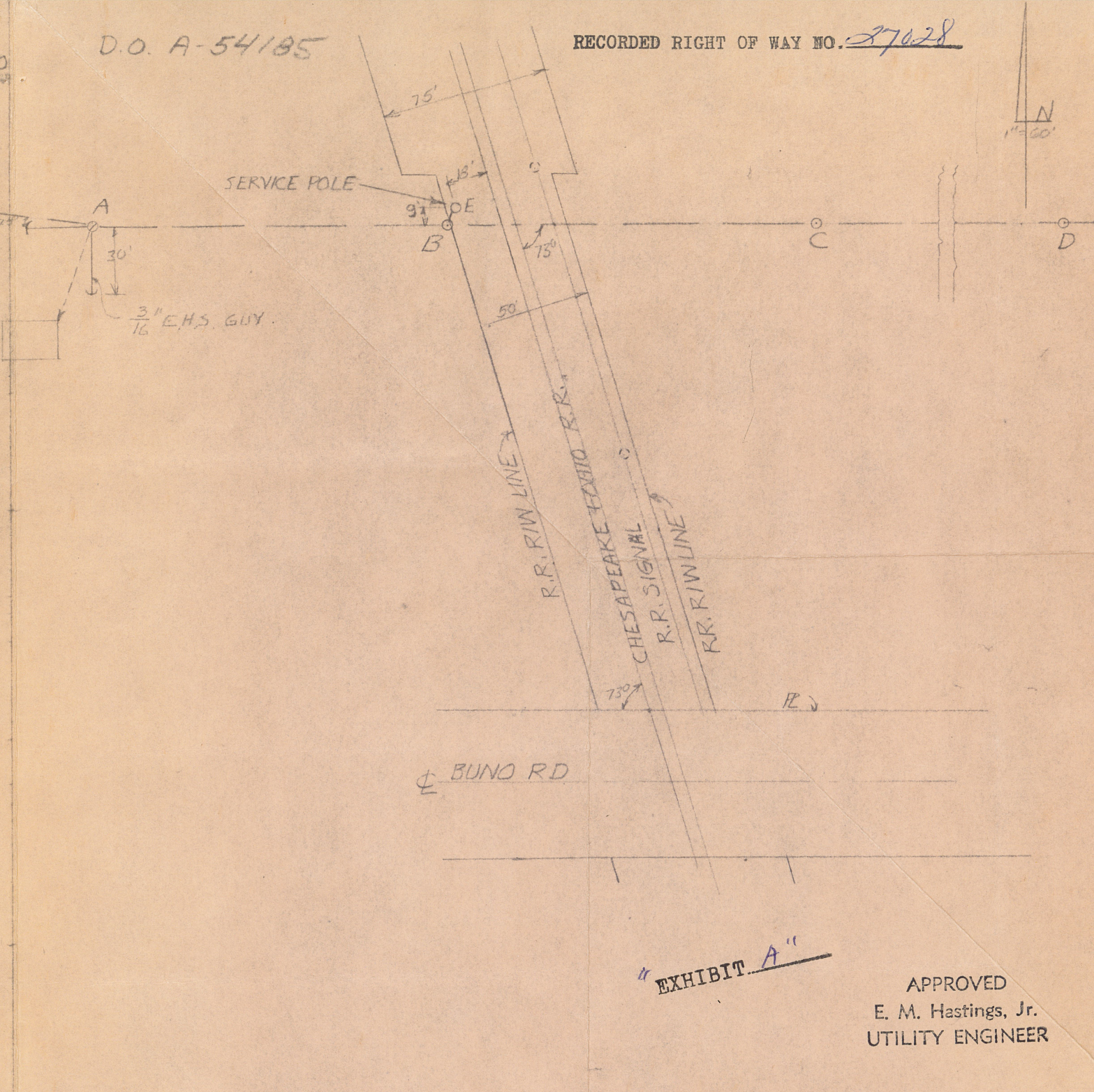

EXHIBIT A

APPROVED
 E. M. Hastings, Jr.
 UTILITY ENGINEER

Approved
 G.O. Decker